

SYDNEY C [PKB 8mm]

SYDNEY C CLEAR [PK 4mm]

[V-02] BOX



VERZE: 04.11.2021 / REVIZE: 12.09.2022

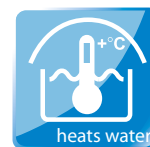

BG
 Покривка за басейни: сива конструкция
 с покритие от ALBIXON - NF P 90-309
 Застъпване на покритието не трябва да се извършва от деца и възрастни, които не са обучени за целта.

CZ
 Bazénové zastrešenie: sivá konštrukcia
 s krytinou ALBIXON - NF P 90-309
 Zastavenie krytiny musí byť zabezpečené magistrami.

DE
 Schwimmbeckenüberdachung: sivá konštrukcia
 s krytinou ALBIXON - NF P 90-309
 Das Gitter der Gabelstapler darf nicht betreten werden.
 Die Gitter der Gabelstapler dürfen nicht betreten werden.
 Die Gitter der Gabelstapler dürfen nicht betreten werden.

DK
 Bassinoverdækning: siv konstruktion
 med ALBIXON - NF P 90-309
 Gitteret skal sikres for sikkerhed ved at begrænse tilgængeligheden eller sænke overgangens højde.

ES
 Cubierta de piscinas: estructura ligera
 con ALBIXON - NF P 90-309
 Evitar que otros niños o personas adentro o afuera del área asegurada por el propietario.

EE
 Basini kaetmine: lihtsstruktuuriline
 konstruktsioon ALBIXON - NF P 90-309
 Järelkasutajate tuleb hoida piiratud juurdepääsu piiride abil ohutu ja piiratud juurdepääsu piiride abil.

FR
 Niveaux de piscines: construction légère
 conforme à norme ALBIXON - NF P 90-309
 Éviter que d'autres enfants ou personnes du public ne pénètrent dans l'enceinte assurée par le propriétaire.

GB
 The swimming pool enclosure: light weight construction
 conforming to ALBIXON - NF P 90-309
 The enclosure must ensure that the pool is secure or adjacent enclosure has to be secured by owner.

HU
 Medencefedélzetek: könnyű szerkezet
 ALBIXON - NF P 90-309 megfelel
 A fedélzet használatát a tulajdonosnak kell biztosítani.

HR
 Nadstrešnice bazena: laka konstrukcija
 u skladu sa ALBIXON - NF P 90-309
 Održavanje mora osigurati sigurnost ili sigurnost mora biti osigurana od strane vlasnika.

CN
 游泳池 罩棚
 应符合 ALBIXON - NF P 90-309
 应确保其他人不得进入游泳池区域。

IT
 Copertura per piscine: costruzione leggera
 secondo ALBIXON - NF P 90-309
 Evitare che altri minori o persone sconosciute entrino nell'area assicurata dal proprietario.

LT
 Šiluminė vandens baseinų konstrukcija
 su ALBIXON - NF P 90-309
 Užtikrinti, kad kiti vaikai ar nepažįstami asmenys nepatektų į užtikrintą zoną.

LV
 Bāzēnu jumts: viegla konstrukcija
 saskaņā ar ALBIXON - NF P 90-309
 Pārliecināties, ka citi bērni vai nepazīstami cilvēki neieņemas drošības zonu.

PL
 Zadaszkiwnie basenow: laka konstrukcja
 zgodnie z normą ALBIXON - NF P 90-309
 Zapobiec, aby inni dzieci lub osoby nieznanego pochodzenia nie wchodziły na obszar objęty ochroną.

RO
 Acoperire pentru piscine: constructie usoara
 in conformitate cu ALBIXON - NF P 90-309
 Asigura ca altele persoane sa nu accedez la piscina in zona asigurata de proprietar.

RU
 Тканевые для бассейнов: легкая конструкция
 в соответствии с ALBIXON - NF P 90-309
 Предотвратить доступ к бассейну посторонними лицами, детьми или неизвестными лицами.

SE
 Pooltak: lät konstruktion
 i enlighet med ALBIXON - NF P 90-309
 Förhindra tillgång till bassinet av andra barn eller oönskad publik.

SL
 Nadstrešnice za bazene: laka konstrukcija
 v skladu s ALBIXON - NF P 90-309
 Preprečiti dostop do bazena drugim otroci ali neznanim osebam.

SK
 Bazénové zastrešenie: laka konštrukcia
 v súlade s ALBIXON - NF P 90-309
 Predísť prístupom k bazénu inými deťmi alebo neželanou verečnosťou.

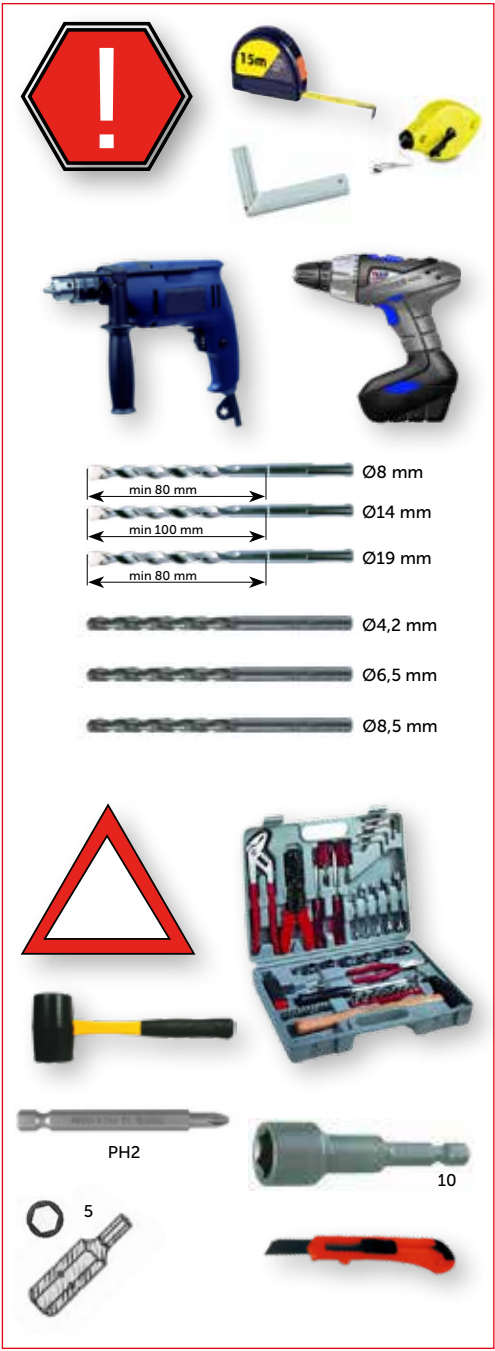

TYP	PRODUKT
KL	SYDNEY - kolej vlevo
	SYDNEY - Rails on the left side only
	SYDNEY - einseitige Schiene links
	SYDNEY - rail d'un seul coté à gauche
	SYDNEY - в исполнении с рельсами с одной стороны - налево

TYP	PRODUKT
KP	SYDNEY - kolej vpravo
	SYDNEY - Rails on the right side only
	SYDNEY - einseitige Schiene rechts
	SYDNEY - rail d'un seul coté à droit
	SYDNEY - в исполнении с рельсами с одной стороны - направо

1SP11-01-032

DIN 7982
4,8 x 13
3x

1

1SZ12-03-021

2x

2

1SZ18-02-001D

4x

3

1SZ18-02-002D

4x

4

1SZ18-01-097

2x

5

1SP07-01-014

ø4 x 8
4x

6

1SP07-01-001

ø4 x 10
112x

7

1SZ03-01-035

DIN 914
M6x14
4x

8

1SP01-01-016

ø8 x 80
28x

9

1SZ12-01-051

4x

10

1SZ29-01-008

4x

11

1SZ03-01-040

4x

12

1SP11-01-029

AN 9051
6,3 x 50
2x

13

1SP11-01-031

AN 9051
6,3 x 70
34x

14

1SP11-01-027

AN 9051
6,3 x 38
4x

15

1SP11-01-053

AN 9051 A4
6,3 x 32
22x

16



1NA03-01-050

1x

17

1CH02-01-011
1SZ28-01-001

1x

18

1SZ01-02-007 1SP03-01-008 1SP11-01-010

a b c

9x 9x 27x

DIN 7982 TX

5,5x45

Pouze pro dřevěné a dřevoplastové podlahy
Only for wooden and wood-plastic floors
Nur für Holz- und Holz-Kunststoffböden
Uniquement pour les planchers en bois et en bois-plastique
Только для деревянных и древесно-пластиковых полов

2Z06-03-SD001

9x

19

2Z06-03-SD004

6x

KEY

4x

20

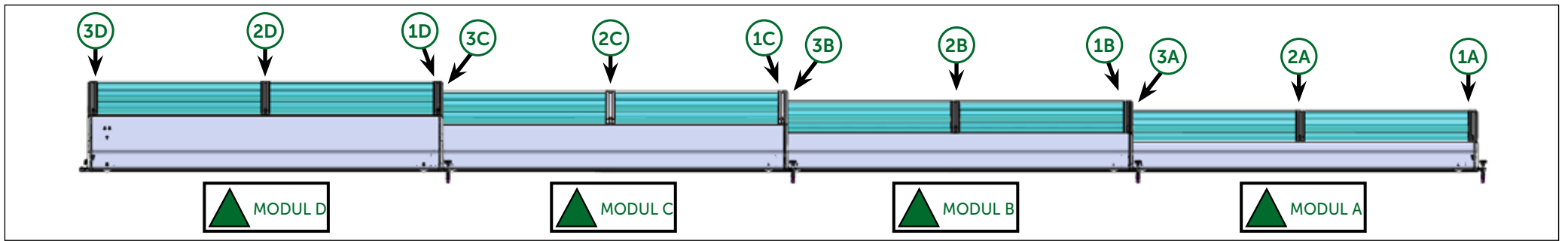

2Z12-04-SM005D - 1A
2Z12-04-SM006D - 2A
2Z12-04-SM007D - 3A

1A, 2A, 3A

MODUL A

1A	1x	21
2A	1x	22
3A	1x	23

2Z12-04-SM008D - 1B
2Z12-04-SM009D - 2B
2Z12-04-SM010D - 3B

1B, 1C, 2B, 2C, 3B, 3C

MODUL B

1B	1x	24
2B	1x	25
3B	1x	26

2Z12-04-SM011D - 1C
2Z12-04-SM012D - 2C
2Z12-04-SM013D - 3C

MODUL C

1C	1x	27
2C	1x	28
3C	1x	29



2Z12-04-SM014D - 1D
2Z12-04-SM015D - 2D
2Z12-04-SM016D - 3D

MODUL D		
1D	1x	30
2D	1x	31
3D	1x	32

Sydney C/ Clear C
2Z04-01-SD002 1032mm

48x
36

Sydney C/ Clear C
2Z05-01-SD003 1032mm

8x
37

2Z01-01-SD045

3230 mm
1x
40

2Z01-01-SD047

Sydney C/ Clear C 2190 mm

1x
41



2Z01-01-SD049

D
3230 mm
1x
42

2Z01-01-SD002

D
3230 mm
4x
43

2Z01-01-SD043

Sydney C / Clear C 2190 mm

B
2x
44

MODUL A

2Z12-04-DP020

237 mm
1x
45

MODUL D

2Z12-04-DP018

419 mm
1x
46

MODUL A

2Z12-04-DP019

4549 mm
1x
47

MODUL D

2Z12-04-DP017

4969 mm
1x
48



MODUL D

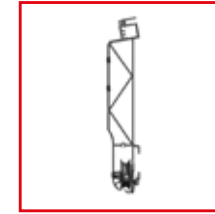

Sydney C/ Clear C
2Z02-09-SR025 2150 mm

1x
50

MODUL D

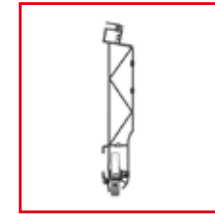

Sydney C/ Clear C
2Z02-09-SR026 2150 mm

1x
51

MODUL C

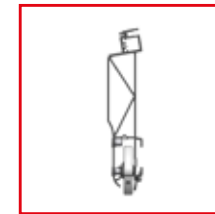

Sydney C/ Clear C
2Z02-09-SR023 2150 mm

1x
52

MODUL C

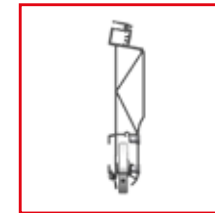

Sydney C/ Clear C
2Z02-09-SR024 2150 mm

1x
53

MODUL B			Sydney C/ Clear C 2Z02-09-SR021 2150 mm	1x 54
----------------	--	--	--	-----------------

MODUL B			Sydney C/ Clear C 2Z02-09-SR022 2150 mm	1x 55
----------------	--	--	--	-----------------

MODUL A			Sydney C/ Clear C 2Z02-09-SR019 2150 mm	1x 56
----------------	--	--	--	-----------------

MODUL A			Sydney C/ Clear C 2Z02-09-SR020 2150 mm	1x 57
----------------	--	--	--	-----------------



Sydney C/ Clear C
 2Z02-09-SD027 2150 mm

8x
58

Sydney C/ Clear C 2291 x 1042 mm

2Z12-04-DK010 - Sydney C
2Z12-08-DK010 - Sydney C Clear

MODUL A

4x
60

Sydney C/ Clear C 2373 x 1042 mm

2Z12-04-DK011 - Sydney C
2Z12-08-DK011 - Sydney C Clear

MODUL B

4x
61

Sydney C/ Clear C 2432 x 1042 mm

2Z12-04-DK012 - Sydney C
2Z12-08-DK012 - Sydney C Clear

MODUL C

4x
62

Sydney C/ Clear C 2502 x 1042 mm

2Z12-04-DK013 - Sydney C
2Z12-08-DK013 - Sydney C Clear

MODUL D

4x
63

2Z12-04-DK003
2Z12-04-DK004

MODUL A

2x
64

2Z12-12-DK001
2Z12-12-DK002

MODUL D

2x
65



2Z12-04-DO009

MODUL A

2x

66

2Z12-04-DO008

MODUL D

2x

67

⚠ only SYDNEY CLEAR ⚠

2Z12-08-DO010 - Sydney C Clear

Sydney Clear C	2291 mm
Sydney Clear C	1020 mm

MODUL A

8x

68

2Z12-08-DO011 - Sydney C Clear

Sydney Clear C	2373 mm
Sydney Clear C	1022 mm

MODUL B

8x

69

2Z12-08-DO012 - Sydney C Clear

Sydney Clear C	2432 mm
Sydney Clear C	1022 mm

MODUL C

8x

70

2Z12-08-DO013 - Sydney C Clear













Sydney Clear C	2502 mm
Sydney Clear C	1022 mm

MODUL D

8x

71

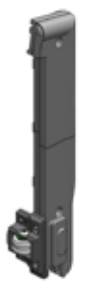
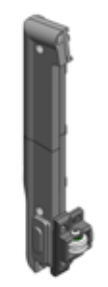
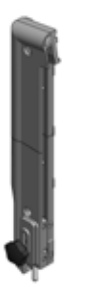
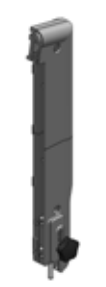

<p>MODUL A</p>  <p>2Z09-01-SD076</p> <p>1x</p> <p>72</p>	<p>MODUL A</p>  <p>2Z09-01-SD077</p> <p>1x</p> <p>73</p>	<p>MODUL A</p>  <p>2Z09-01-SD078</p> <p>1x</p> <p>74</p>	<p>MODUL A</p>  <p>2Z09-01-SD079</p> <p>1x</p> <p>75</p>
<p>MODUL B</p>  <p>2Z09-01-SD072</p> <p>1x</p> <p>76</p>	<p>MODUL B</p>  <p>2Z09-01-SD073</p> <p>1x</p> <p>77</p>	<p>MODUL B</p>  <p>2Z09-01-SD074</p> <p>1x</p> <p>78</p>	<p>MODUL B</p>  <p>2Z09-01-SD075</p> <p>1x</p> <p>79</p>
<p>MODUL C</p>  <p>2Z09-01-SD058</p> <p>1x</p> <p>80</p>	<p>MODUL C</p>  <p>2Z09-01-SD059</p> <p>1x</p> <p>81</p>	<p>MODUL C</p>  <p>2Z09-01-SD060</p> <p>1x</p> <p>82</p>	<p>MODUL C</p>  <p>2Z09-01-SD061</p> <p>1x</p> <p>83</p>
<p>MODUL D</p>  <p>2Z09-01-SD054</p> <p>1x</p> <p>84</p>	<p>MODUL D</p>  <p>2Z09-01-SD055</p> <p>1x</p> <p>85</p>	<p>MODUL D</p>  <p>2Z09-01-SD056</p> <p>1x</p> <p>86</p>	<p>MODUL D</p>  <p>2Z09-01-SD057</p> <p>1x</p> <p>87</p>



2Z09-01-SD020



1x

88

2Z09-01-SD021



1x

89

2Z09-01-SD003



6x

90

1SP10-01-077



DIN 912
M 5x65

4x

91

1SP10-01-084



ISO 7380
M 6x20

12x

92

1SZ18-02-009



8x

93

1SZ18-02-012



16x

94

1SP11-01-049



AN 9051
4,8x60

24x

95

1SP10-01-078



DIN 912
M 6x65

16x

96

1SP10-01-082



DIN 912
M 6x100

24x

97

1SZ03-01-029



8x

98

1SZ03-01-030



16x

99

1SZ12-01-010



32x

100

2Z06-03-SD003



2x

102

1SZ12-01-052



4x

104

1SP11-01-050



AN 9051
4,8x19

2x

105

1SZ04-01-019 1SZ04-01-026 1SP10-01-116 1SP08-01-015



A B C D

DIN 912
M8x20

DIN 440R
M8

2x

106

1SZ12-03-020



1x

107

1SP10-01-025



DIN912
M6x25

10x

108

OPTIONAL "KL"

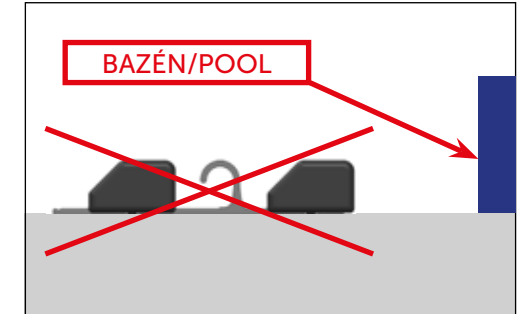
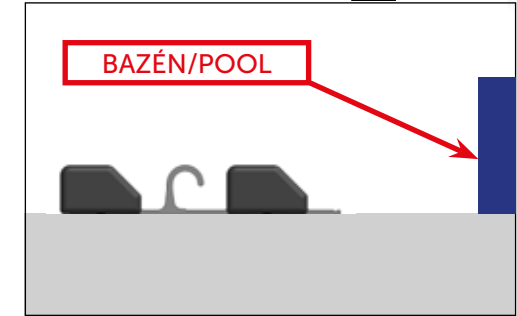
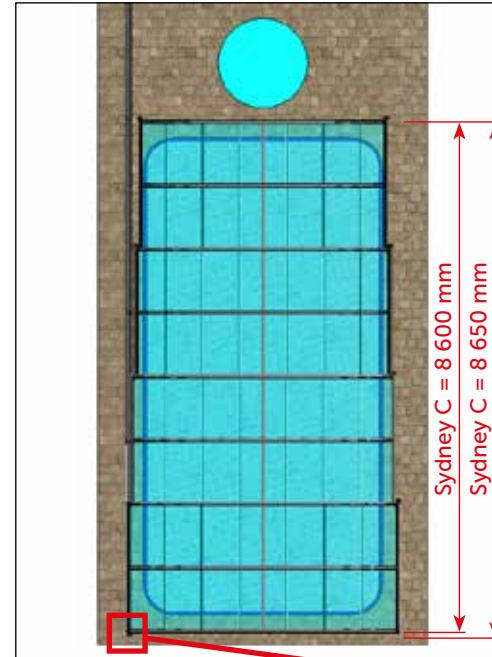
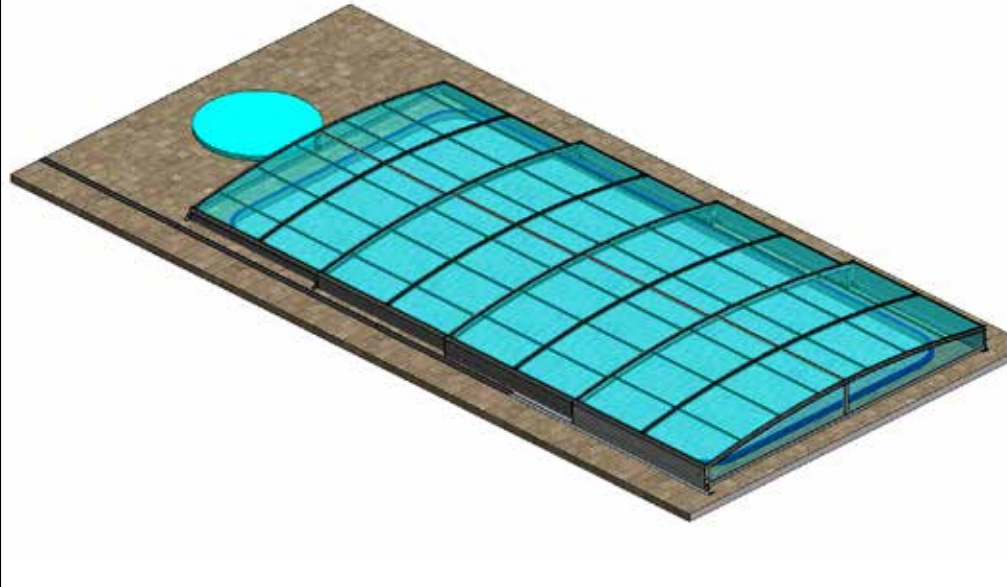

OPTIONAL "R"

- Prodloužení koleji
- Rail extension
- Schienenverlängerung
- Prolongement de rails
- Ríales prolongados
- Продолжение рельсов

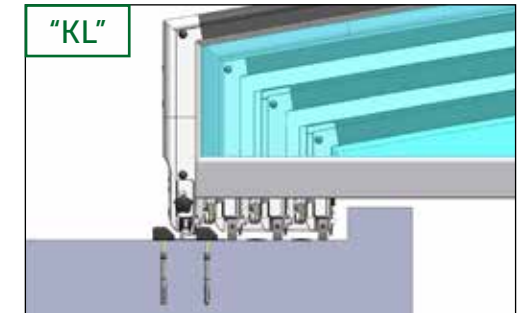
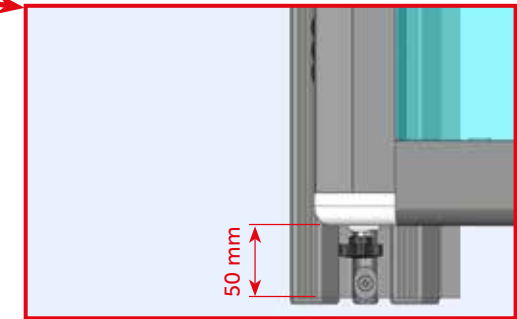
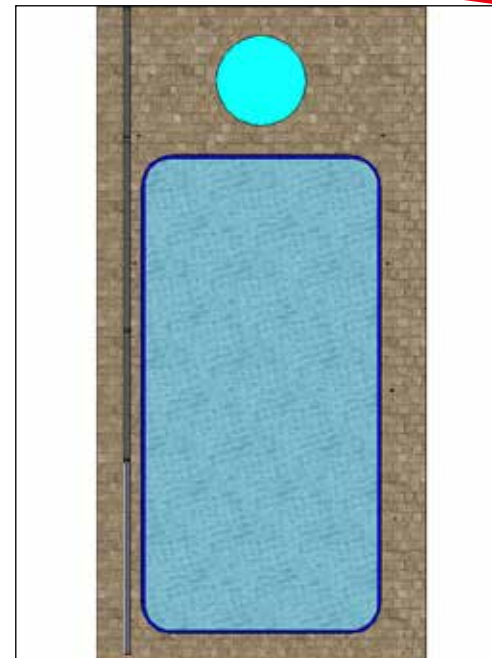
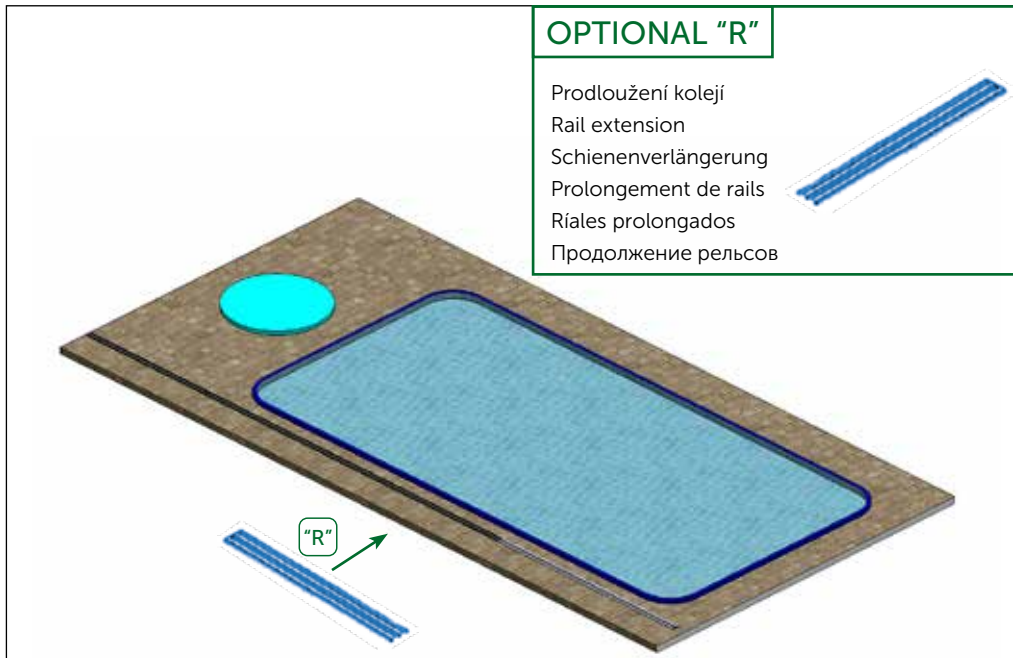
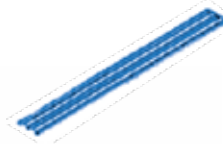

OPTIONAL "KP"

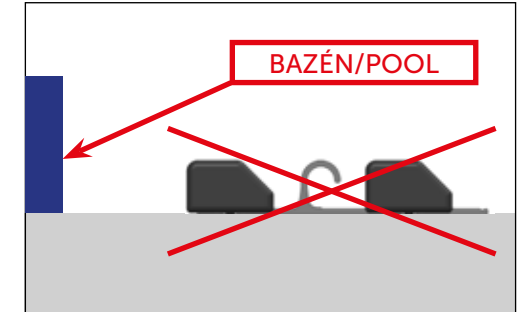
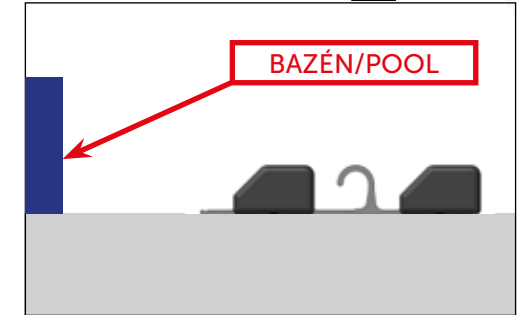
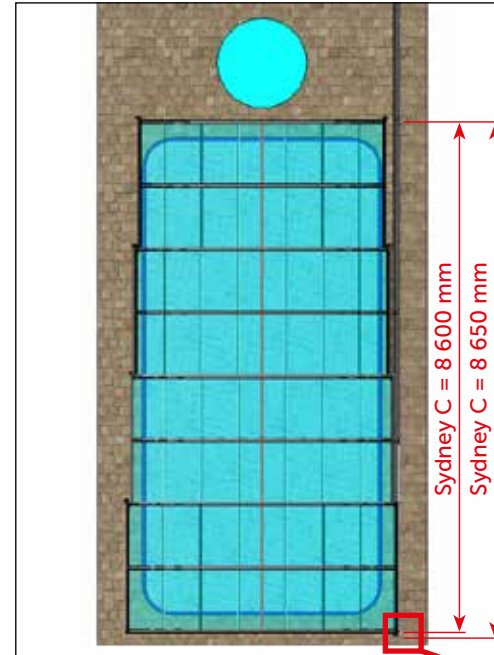
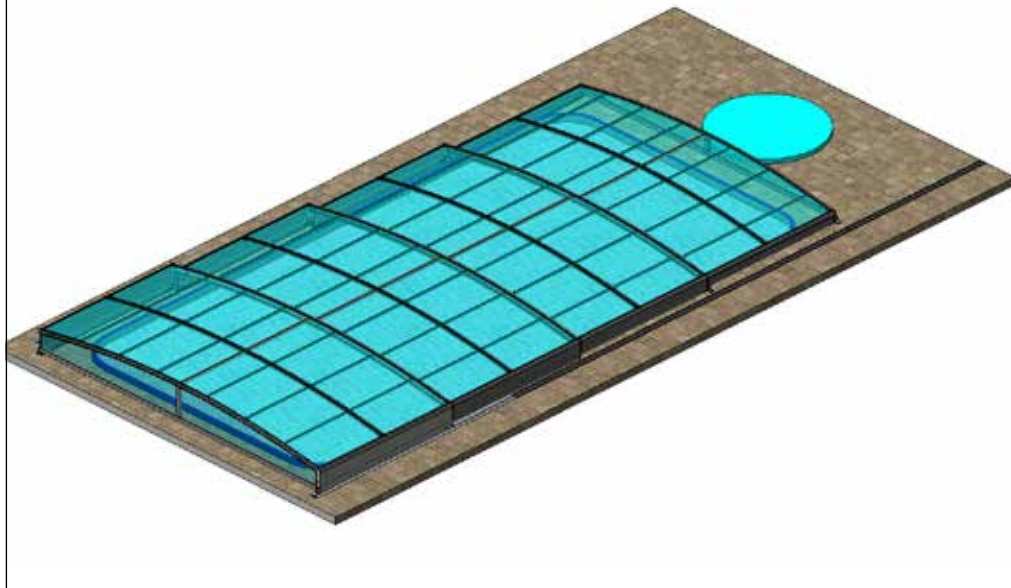

OPTIONAL "R"

- Prodloužení kolejí
- Rail extension
- Schienerverlängerung
- Prolongement de rails
- Riales prolongados
- Продолжение рельсов

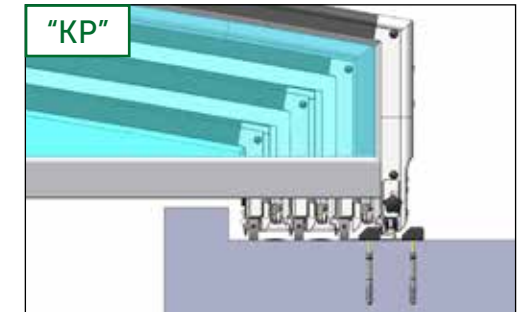
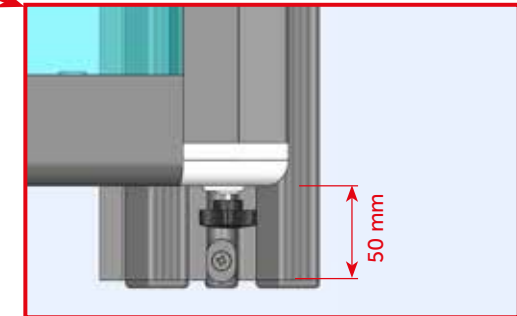
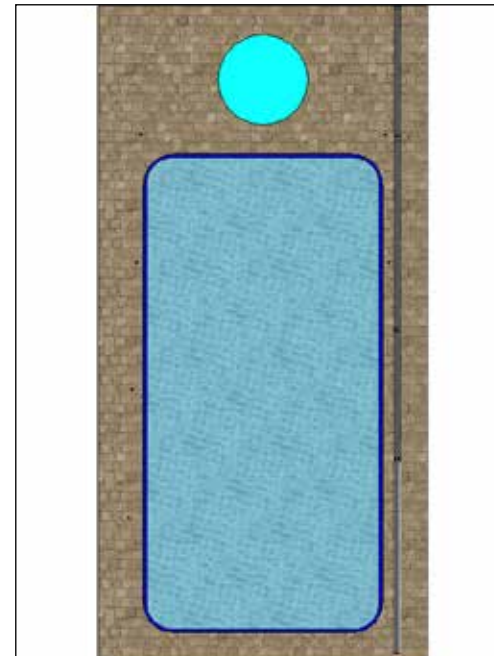
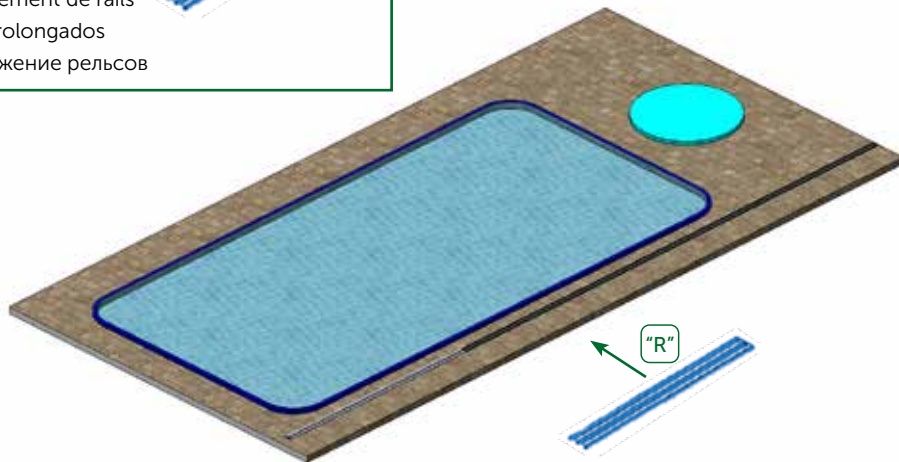
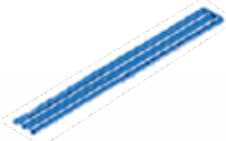

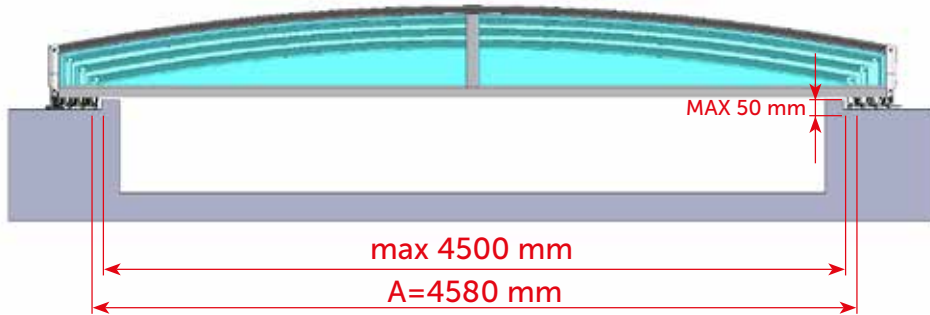

OPTIONAL

- Prodloužení kolejí
- Rail extension
- Schienenverlängerung
- Prolongement de rails
- Ríales prolongados
- Продолжение рельсов

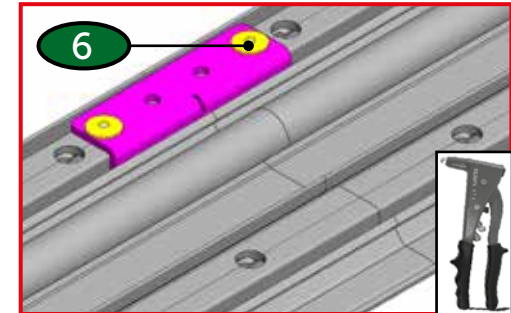
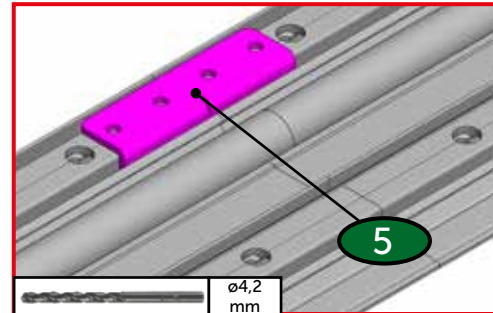
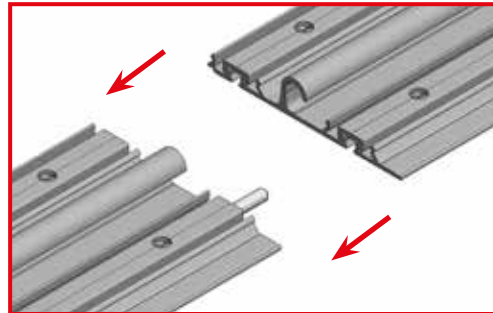
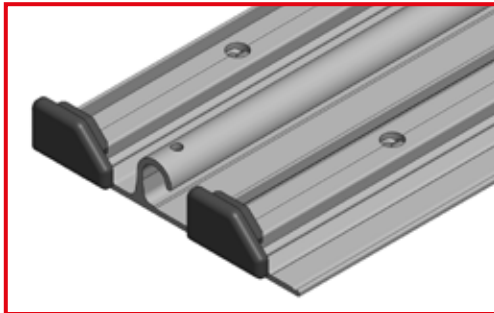
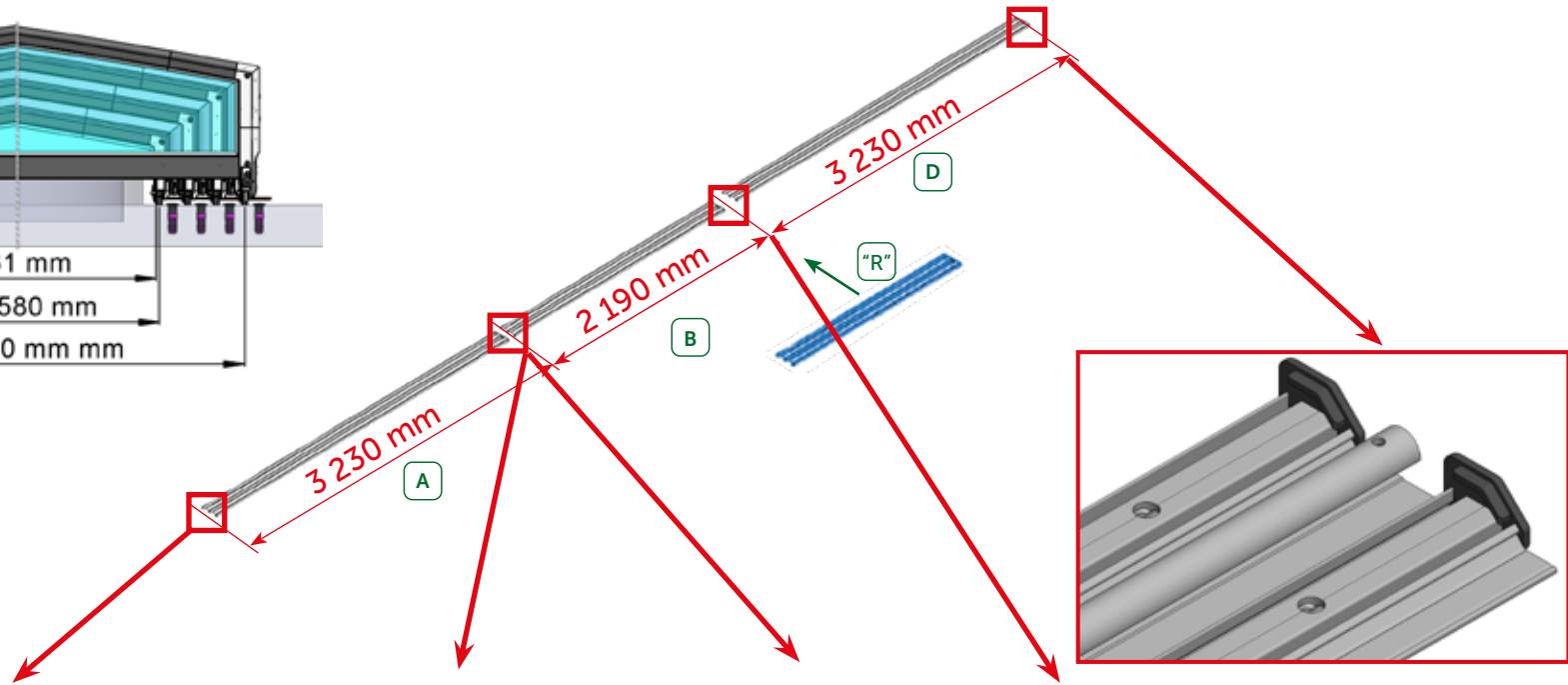
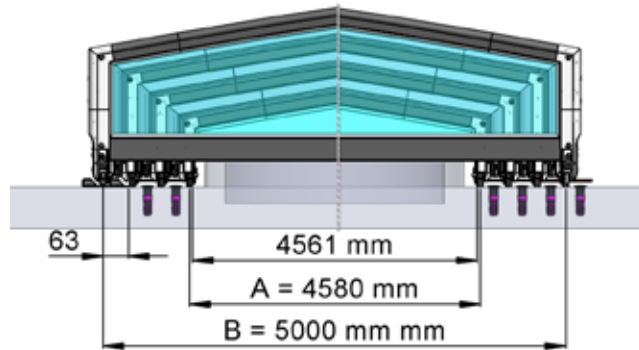

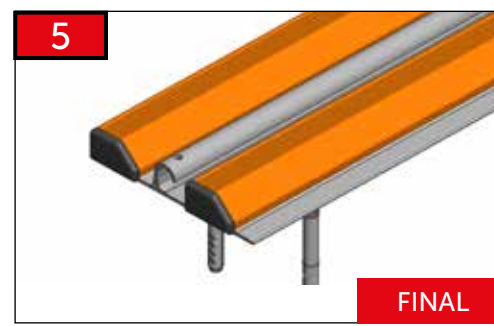
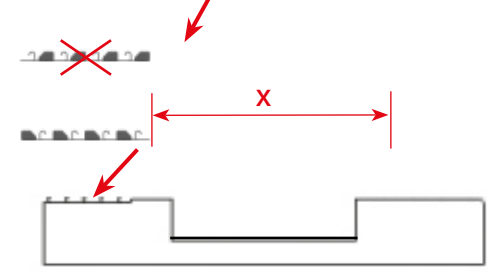
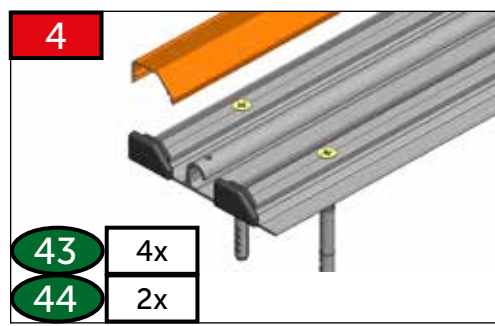
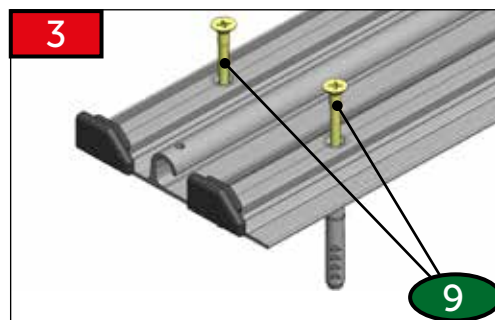
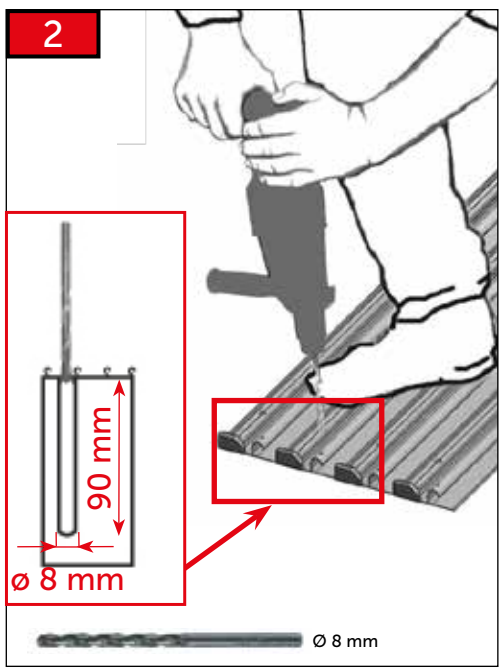
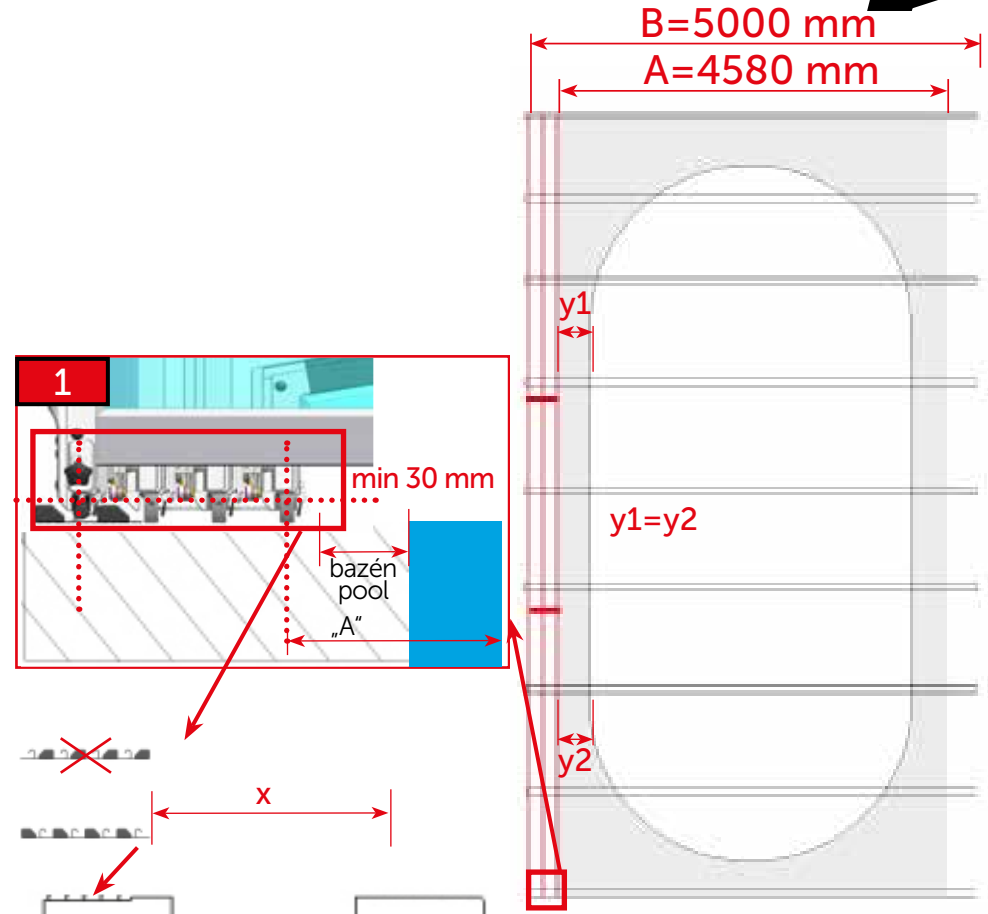
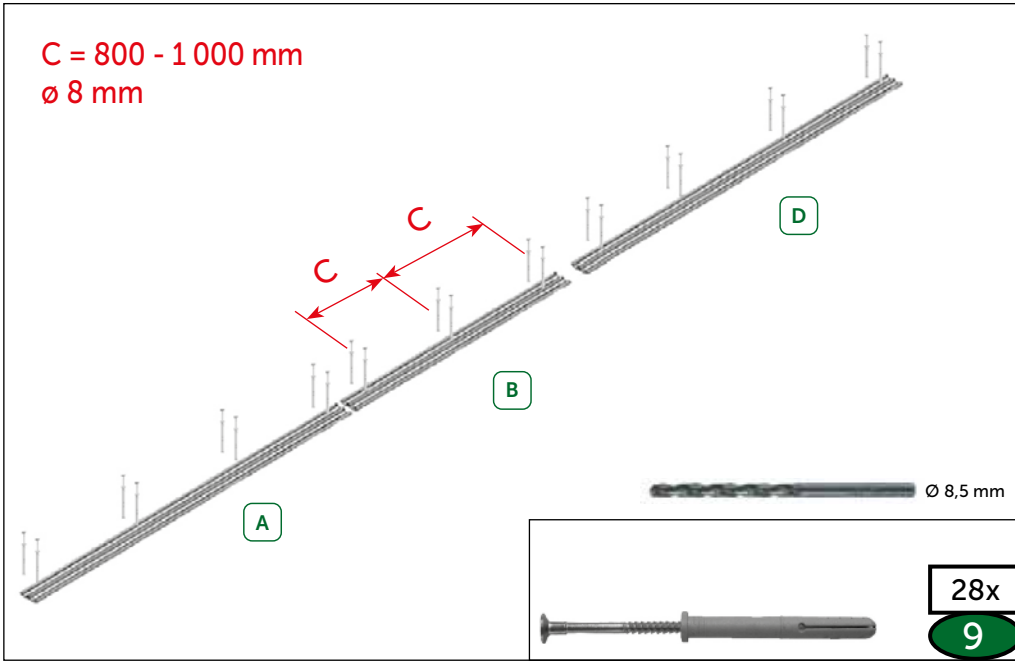

OPTIONAL "KL" - STANDARD

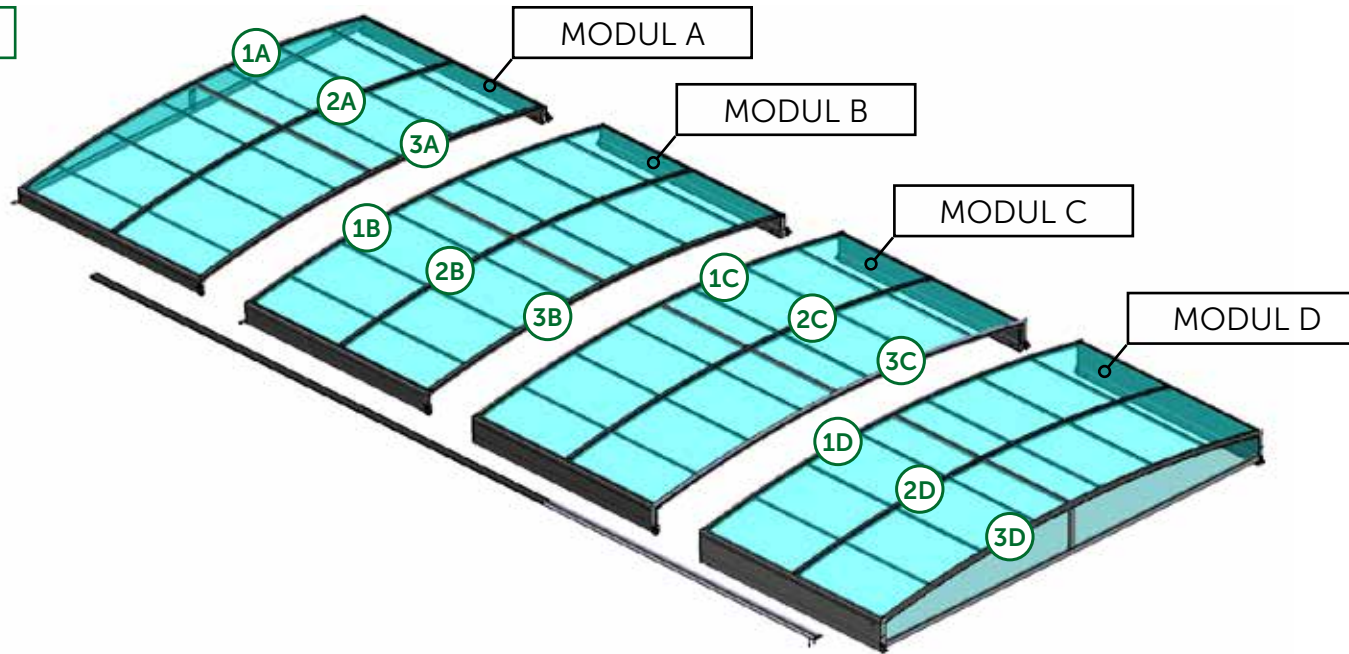



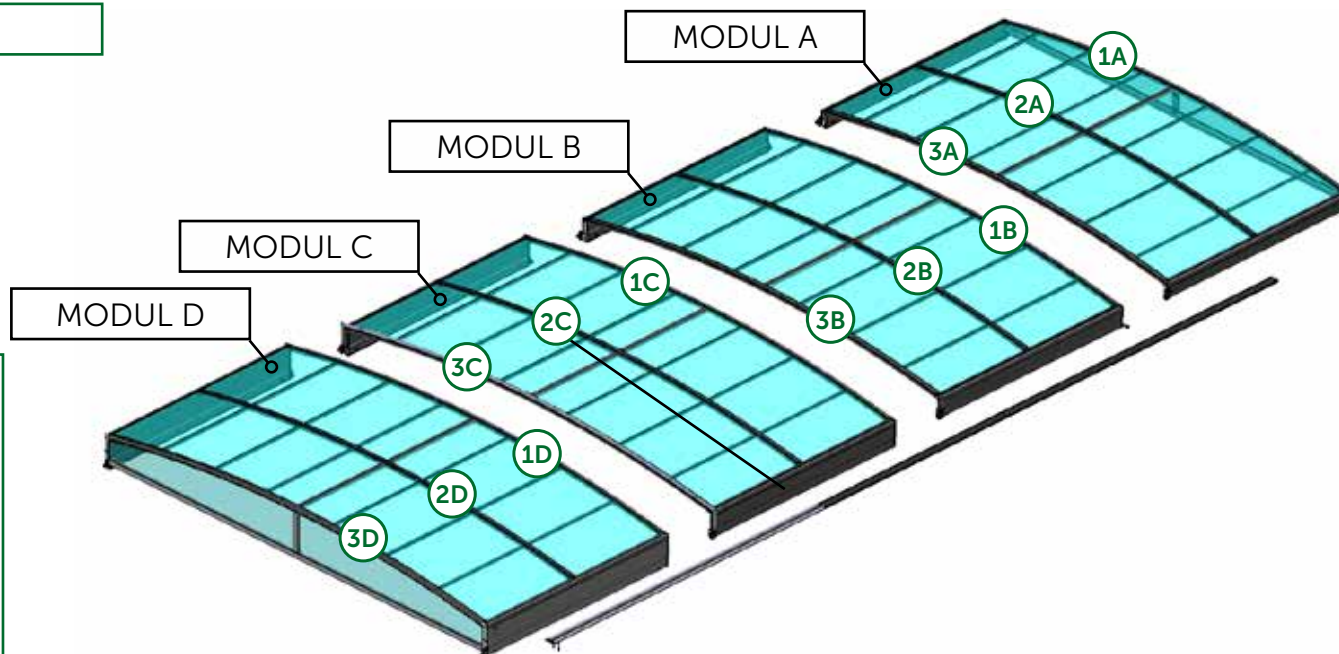





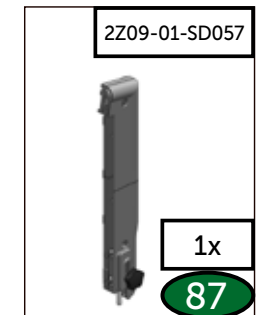
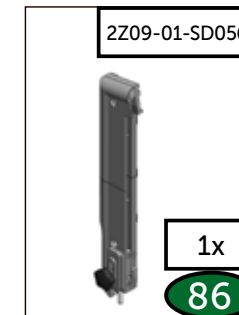
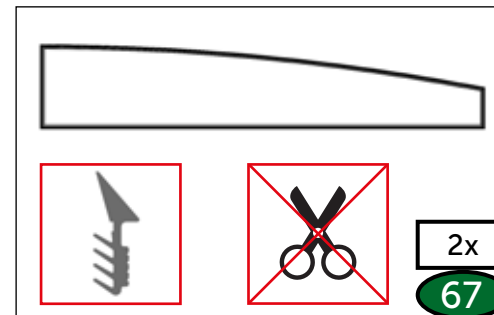
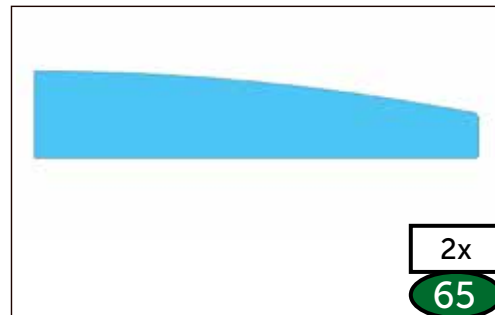
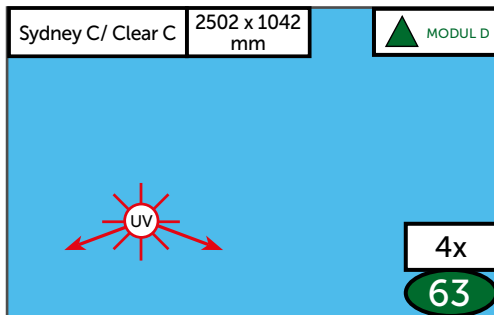
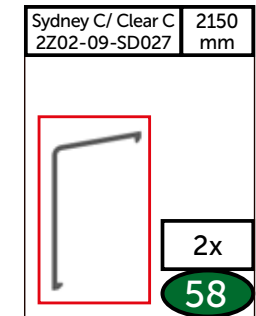
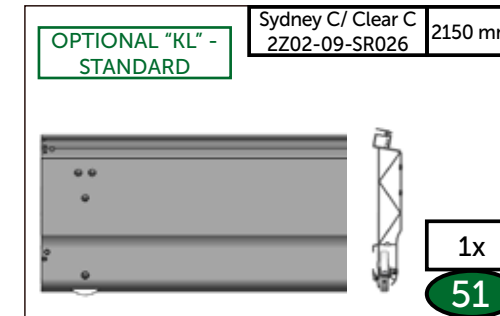
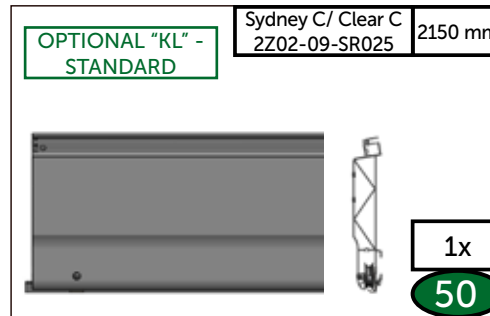
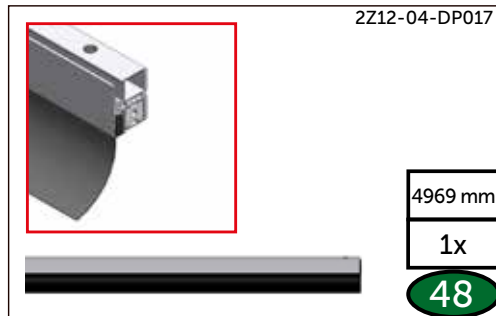
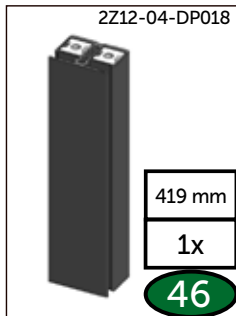
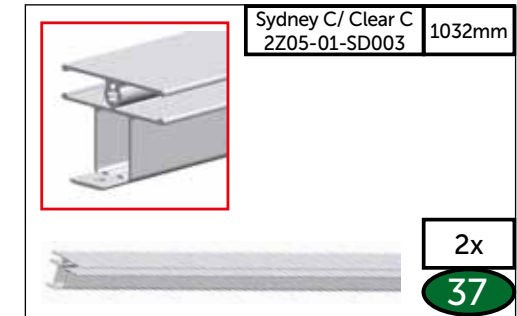
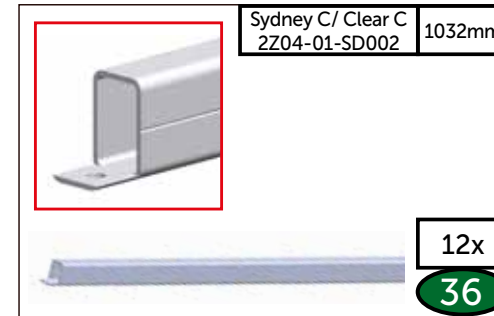
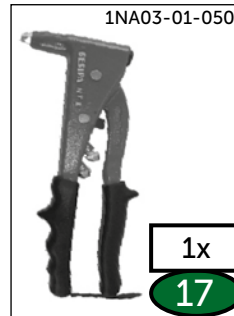
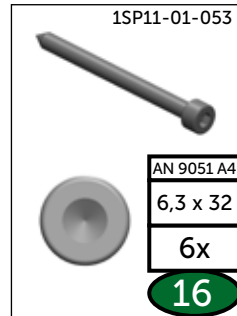
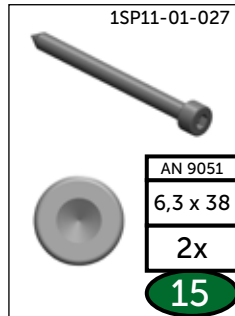
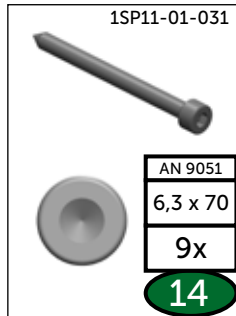
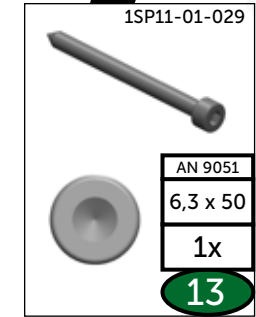
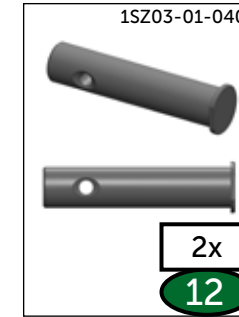
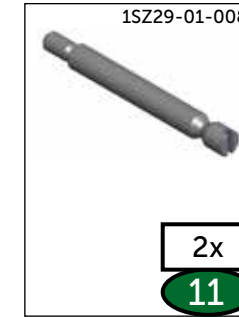
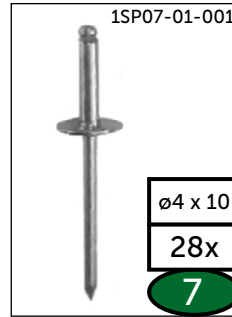
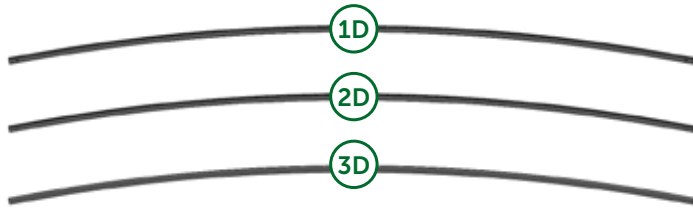











OPTIONAL "KP"

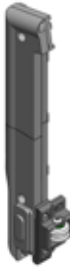

MODUL D

- KL → KP
 = výměna koleček v profilech
 = changing wheels in profiles
 = Radwechsel in Profilen
 = changement de roues dans les profils
 = смена колес в профилях



<p>2Z09-01-SD020</p>  <p>1x</p> <p>88</p>	<p>2Z09-01-SD021</p>  <p>1x</p> <p>89</p>	<p>1SP10-01-077</p>  <p>DIN 912 M 5x65</p> <p>2x</p> <p>91</p>	<p>1SP10-01-084</p>  <p>ISO 7380 M 6x20</p> <p>2x</p> <p>92</p>	<p>1SZ18-02-009</p>  <p>2x</p> <p>93</p>	<p>1SZ18-02-012</p>  <p>4x</p> <p>94</p>	<p>1SP11-01-049</p>  <p>AN 9051 4,8x60</p> <p>6x</p> <p>95</p>	<p>1SP10-01-078</p>  <p>DIN 912 M 6x65</p> <p>4x</p> <p>96</p>
<p>1SP10-01-082</p>  <p>DIN 912 M 6x100</p> <p>6x</p> <p>97</p>	<p>1SZ03-01-029</p>  <p>2x</p> <p>98</p>	<p>1SZ03-01-030</p>  <p>4x</p> <p>99</p>	<p>1SZ12-01-010</p>  <p>8x</p> <p>100</p>	<p>1SZ12-01-052</p>  <p>2x</p> <p>104</p>	<p>1SP11-01-050</p>  <p>AN 9051 4,8x19</p> <p>2x</p> <p>105</p>	<p>1SZ12-01-051</p>  <p>2x</p> <p>10</p>	
<p>2Z09-01-SD054</p>  <p>1x</p> <p>84</p>	<p>2Z09-01-SD055</p>  <p>1x</p> <p>85</p>	<p>1SP10-01-025</p>  <p>DIN912 M6x25</p> <p>4x</p> <p>108</p>					
<p>OPTIONAL "KL"</p> <p>1SZ18-02-001D</p>  <p>1x</p> <p>3</p>	<p>OPTIONAL "KP"</p> <p>1SZ18-02-002D</p>  <p>1x</p> <p>4</p>						

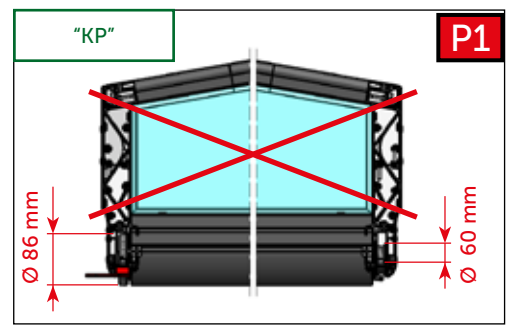
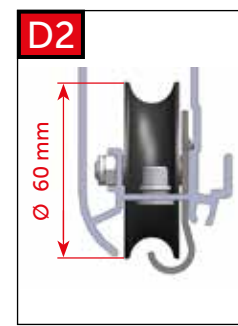
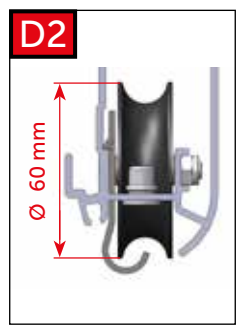
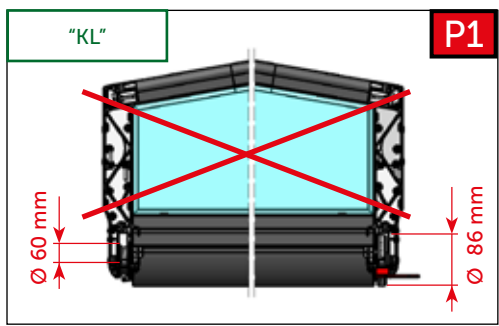
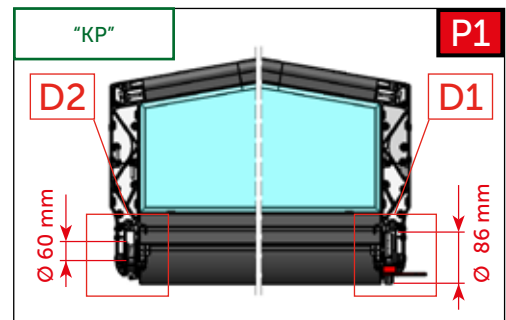
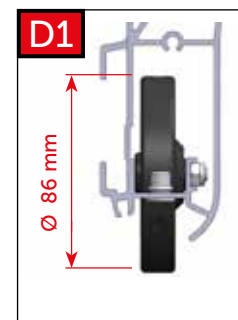
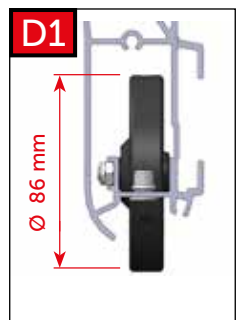
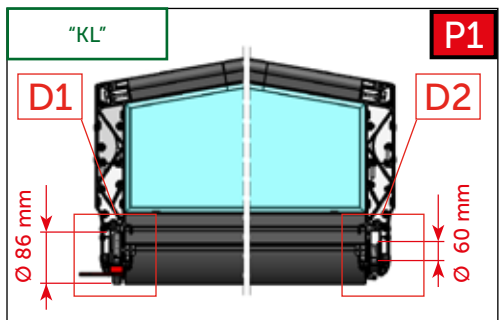
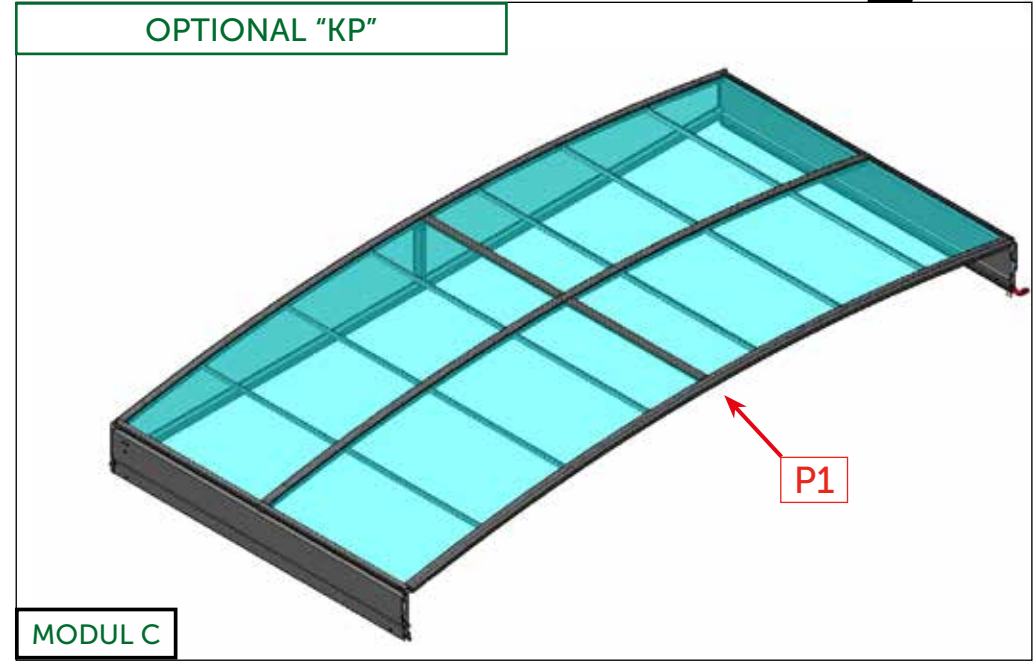
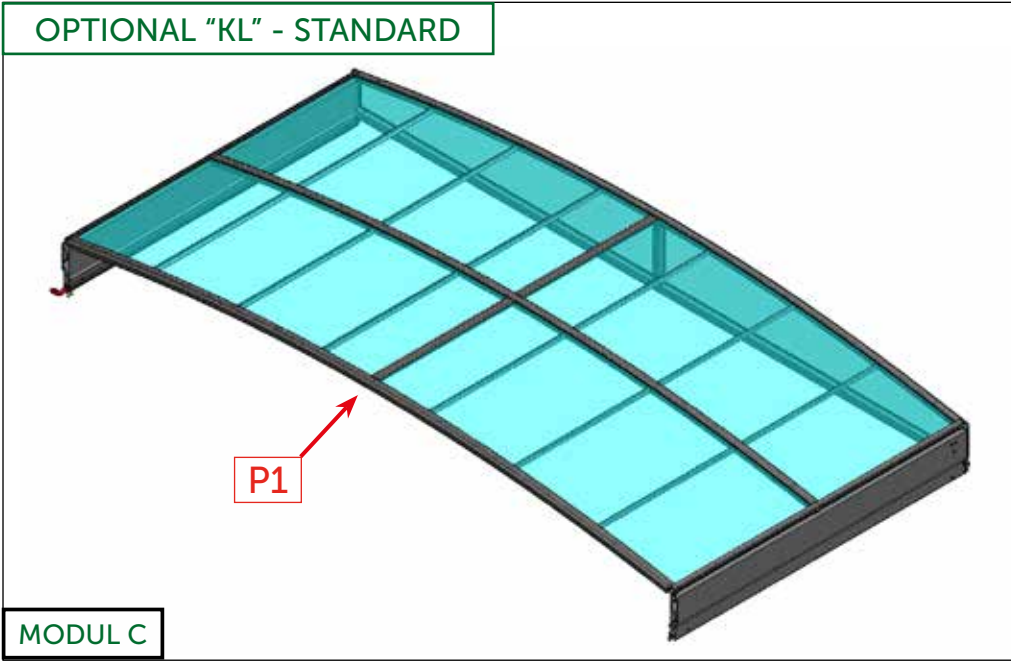

KL → KP
 = výměna koleček v profilech
 = changing wheels in profiles
 = Radwechsel in Profilen
 = changement de roues dans les profils
 = смена колес в профилях

1 KL → KP

1a

- = demontáž
- = disassembly
- = Demontage
- = démontage
- = удаление

1x
50

1

4a

- = demontáž
- = disassembly
- = Demontage
- = démontage
- = удаление

1x
51

1a

2

1.
2.

4a

5

3

1 KL → KP

1a

1a

- = montáž
- = montage
- = Montage
- = assemblage
- = монтаж

1x

50

1

4a

4a

- = montáž
- = montage
- = Montage
- = assemblage
- = монтаж

1x

51

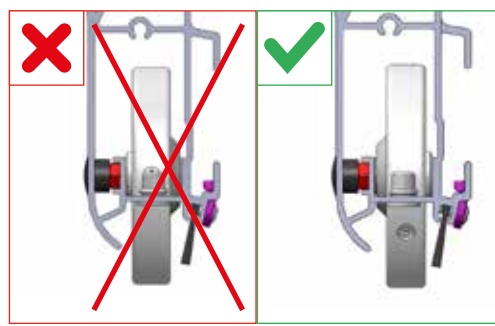
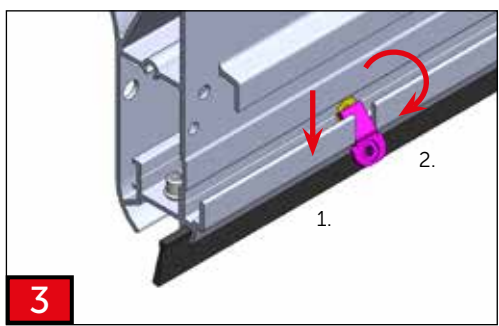
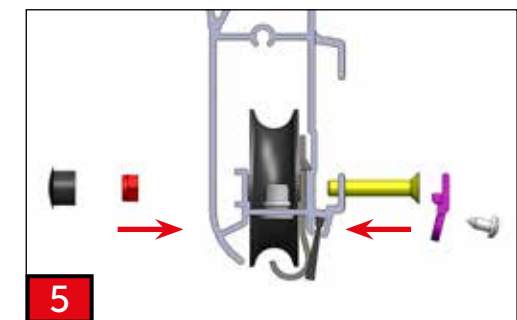
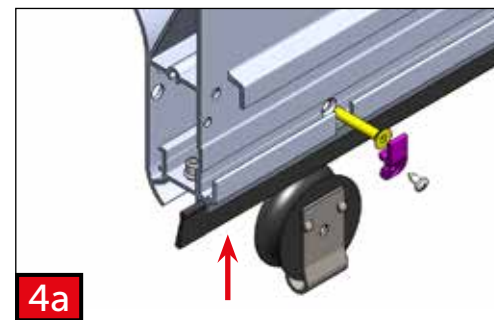
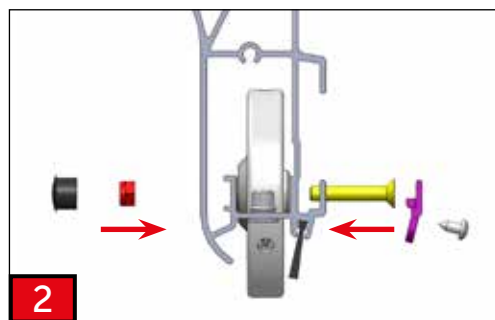
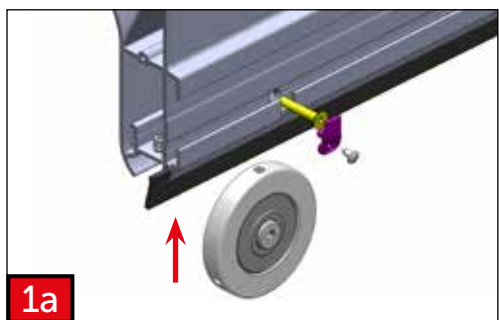

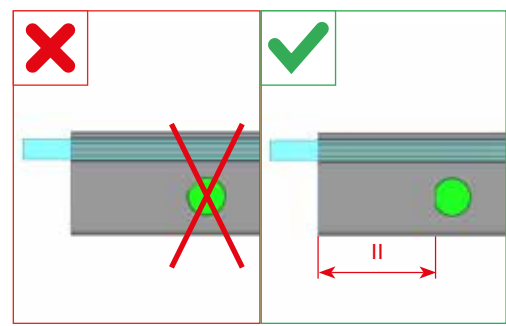
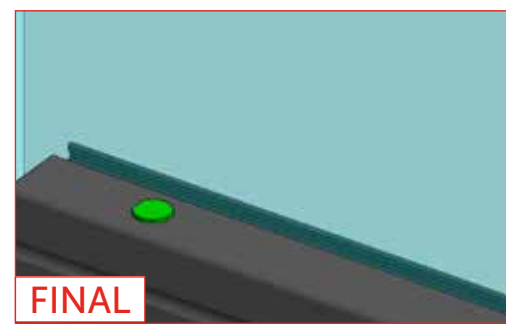
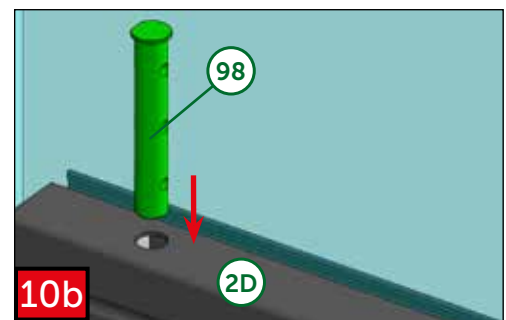
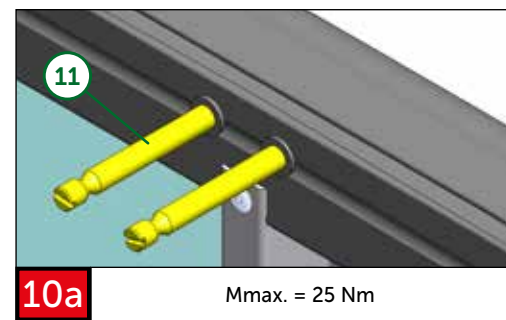
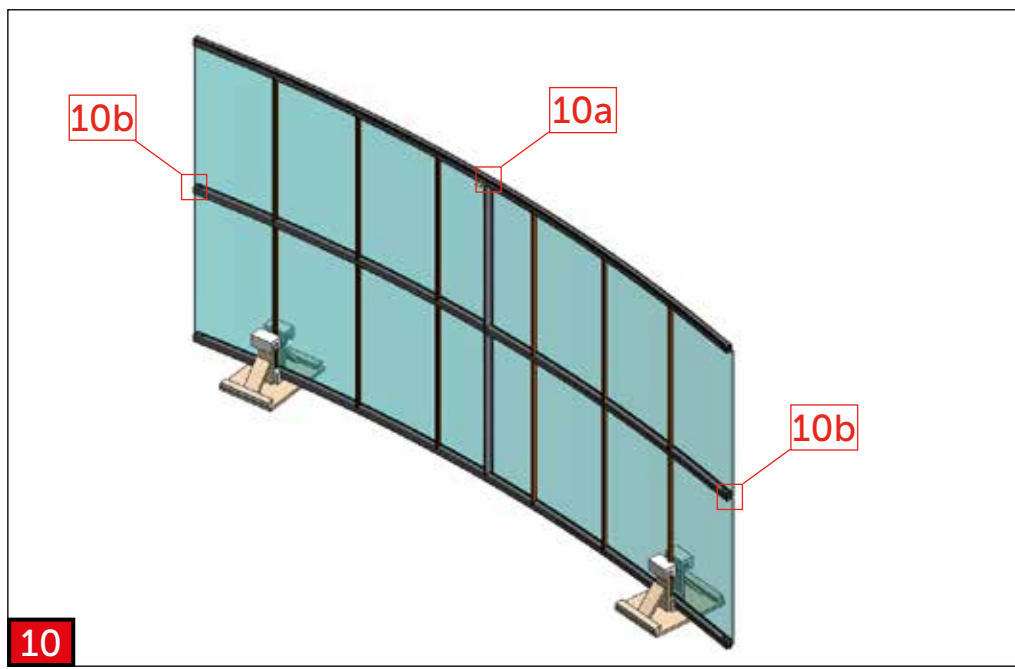
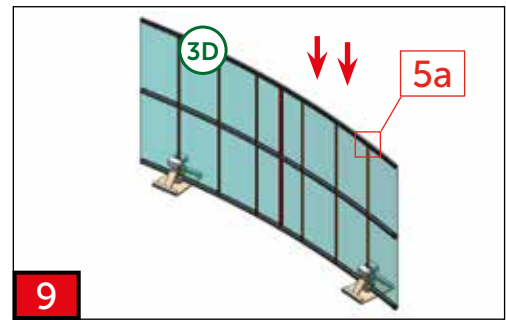
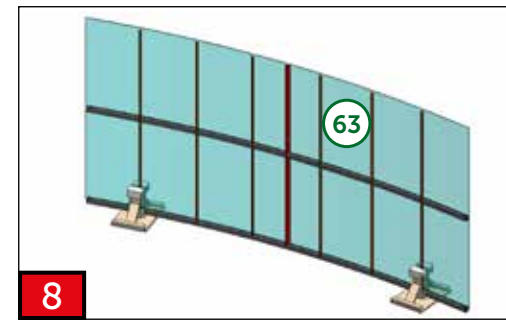
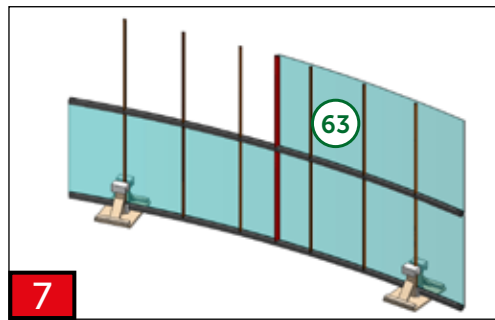
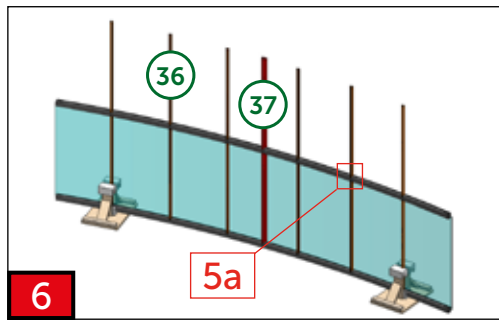
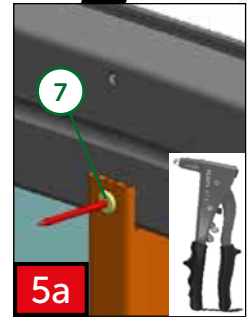
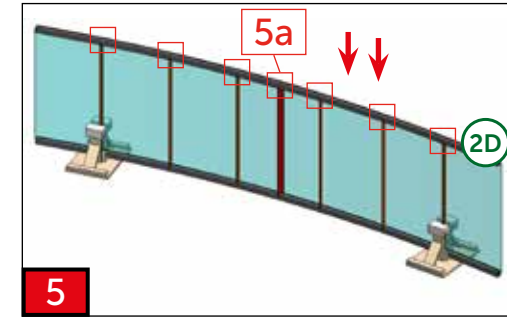
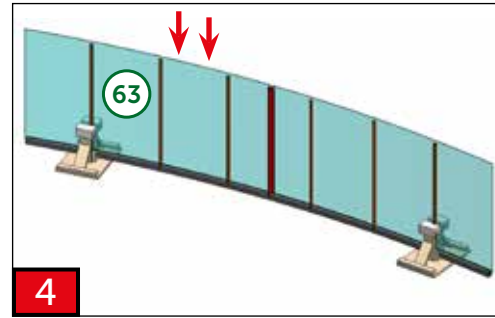
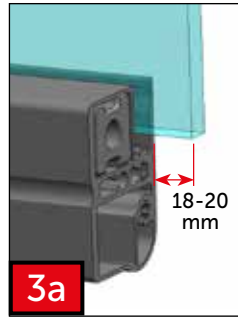
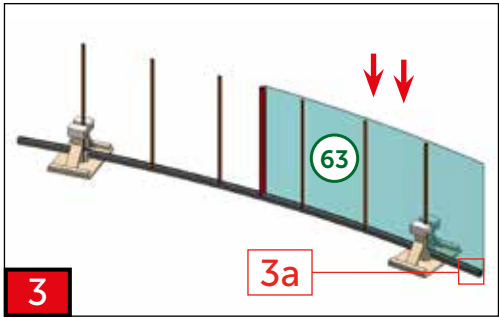

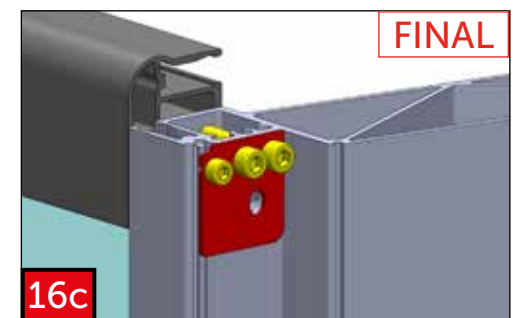
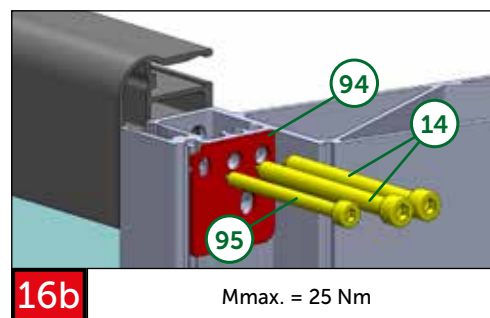
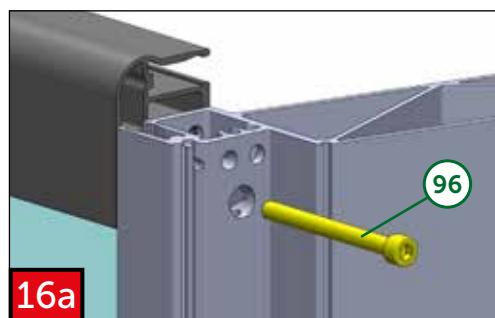
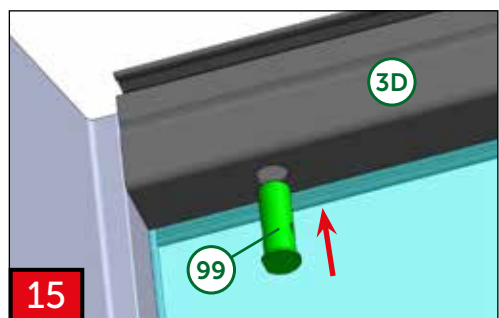
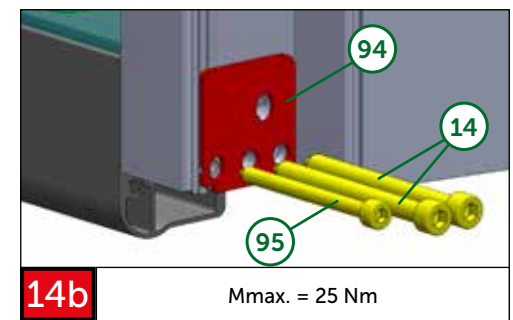
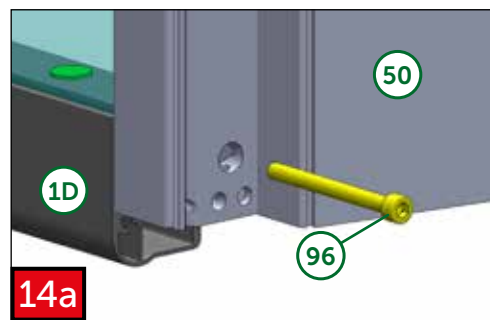
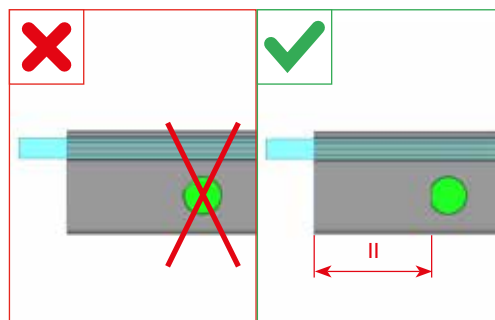
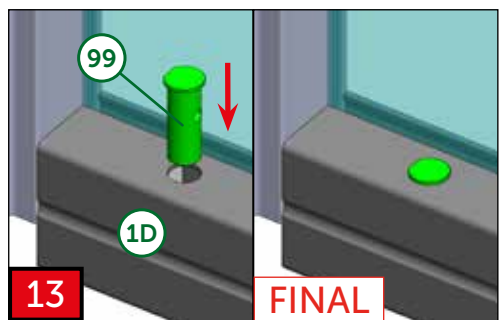
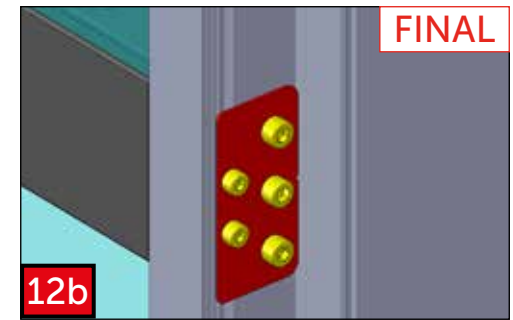
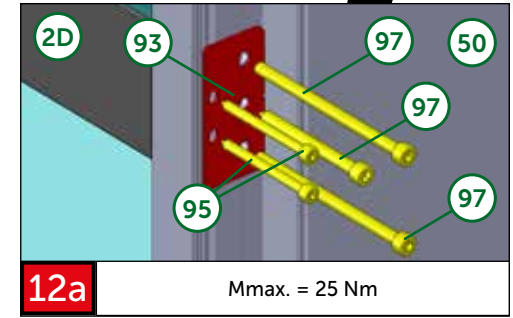
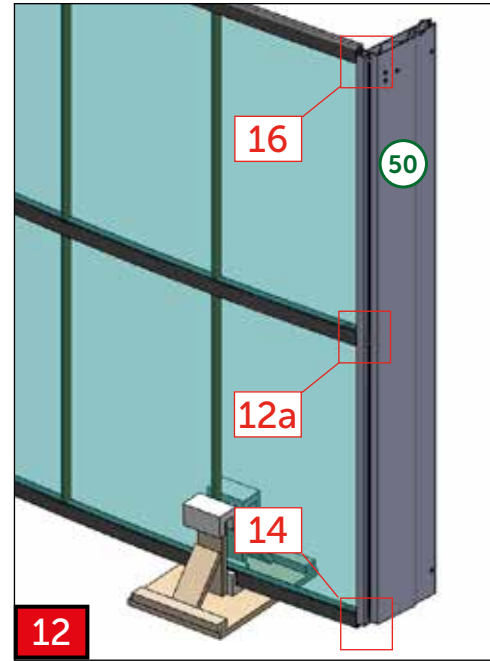
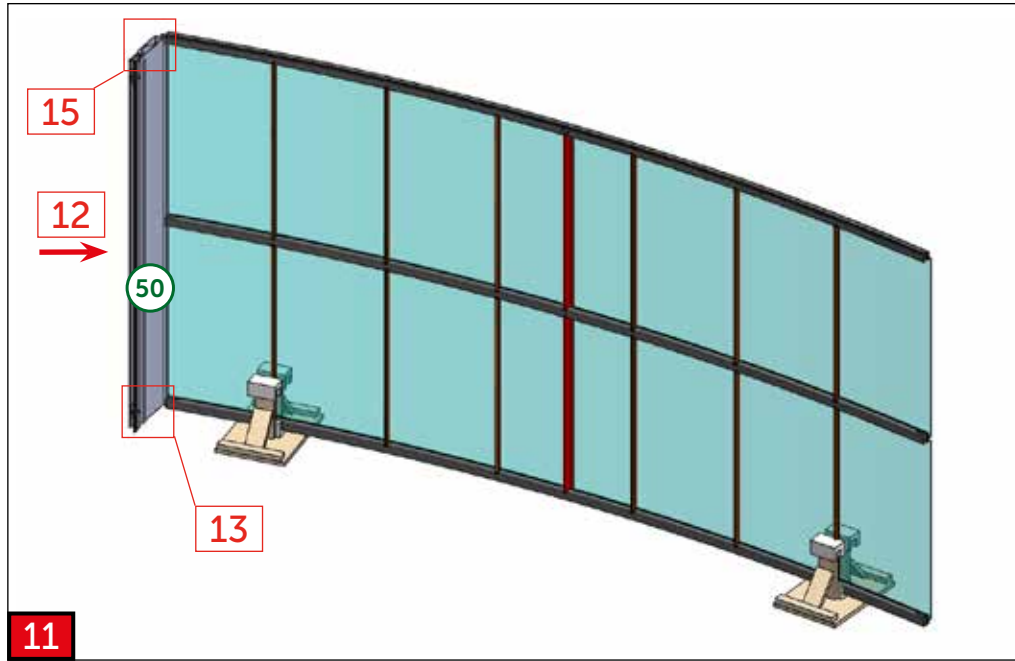

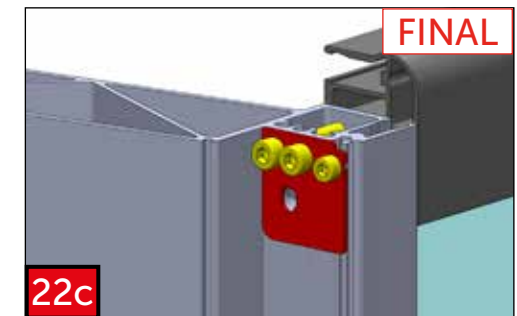
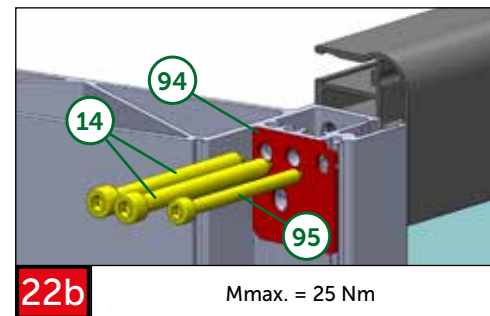
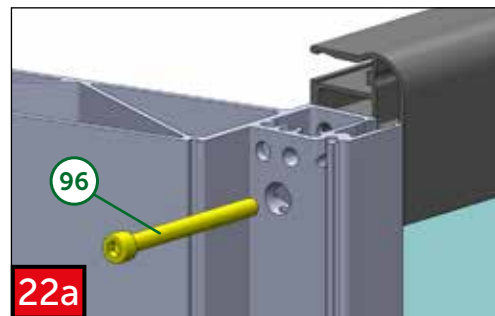
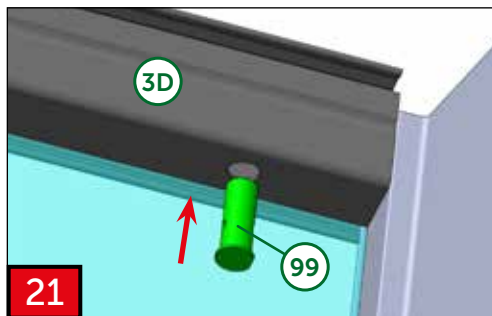
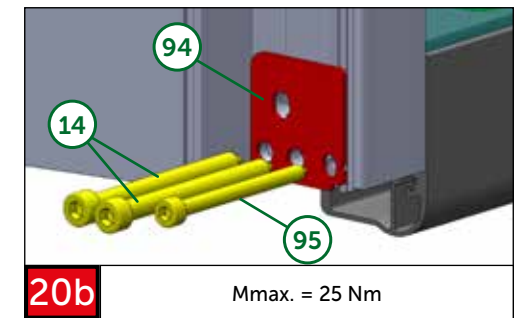
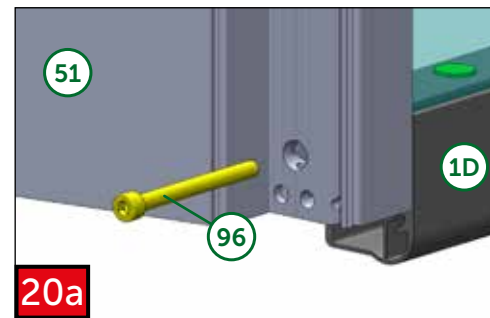
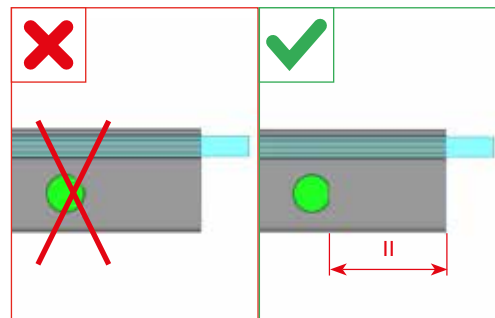
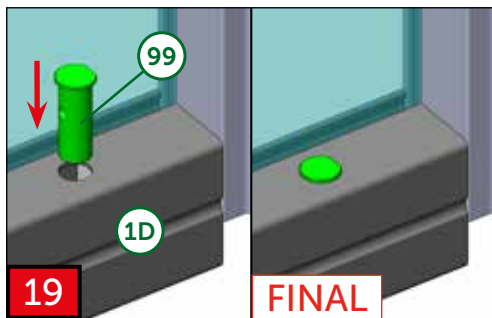
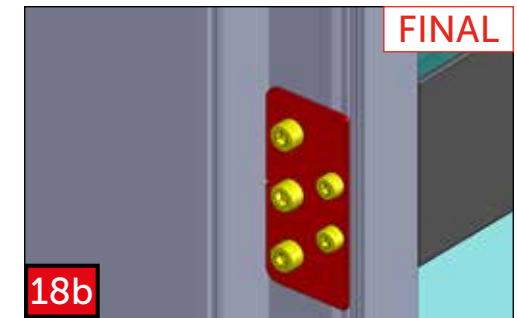
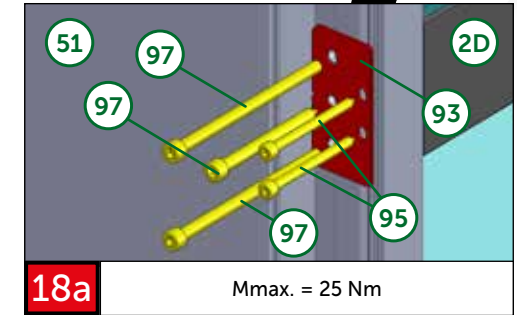
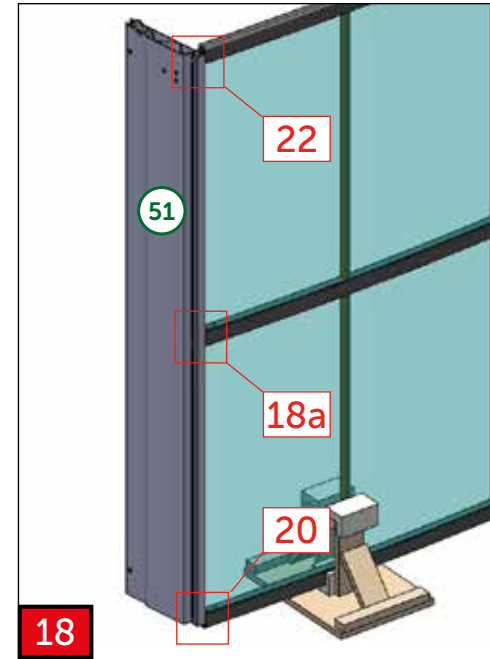
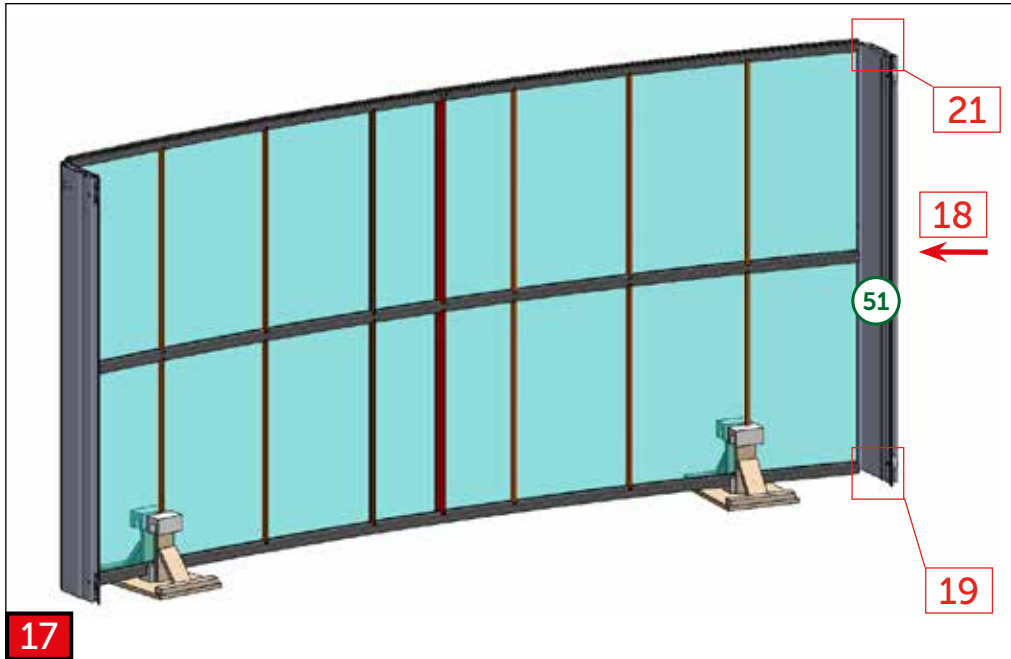

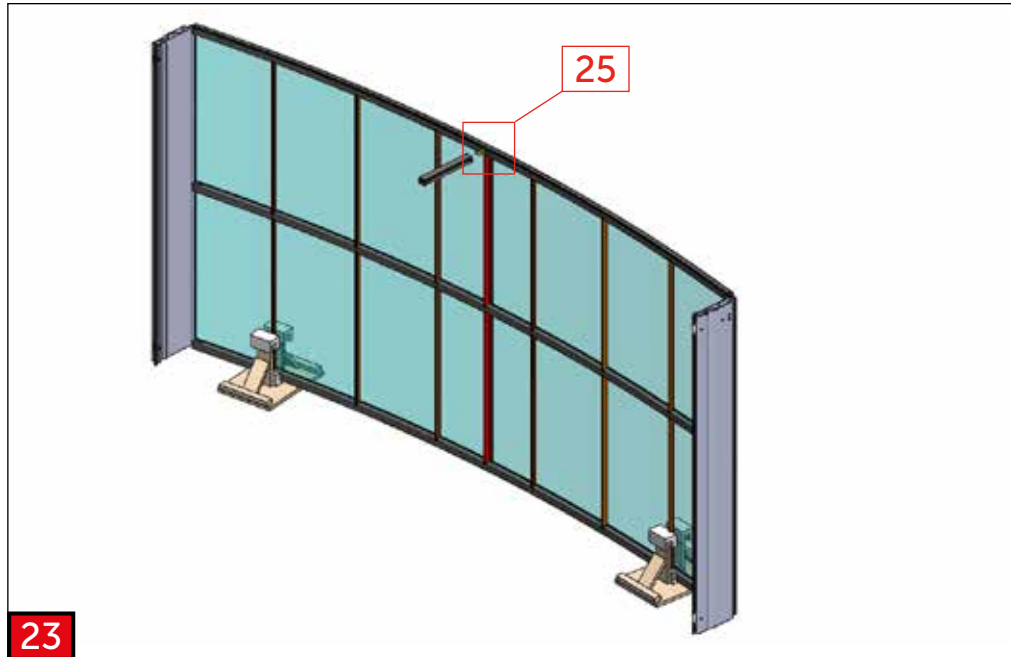

23

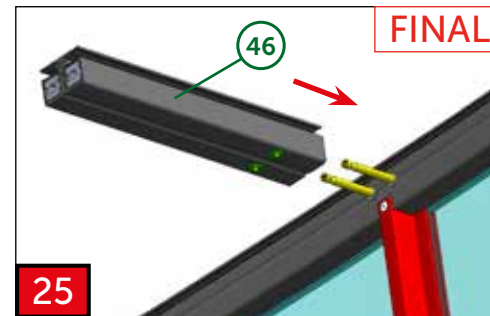
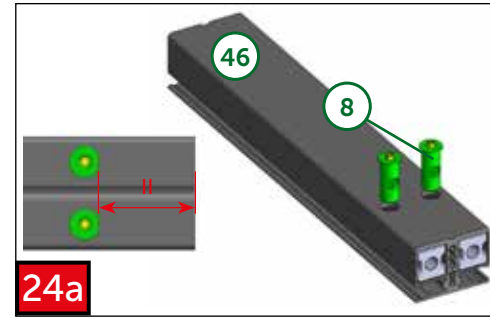

25a

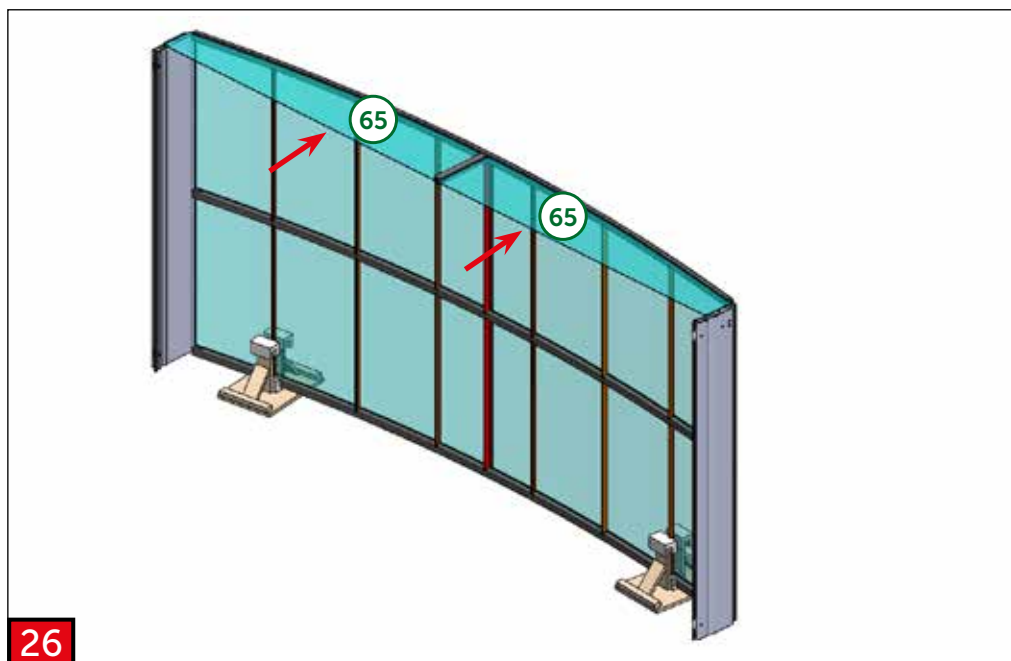

26

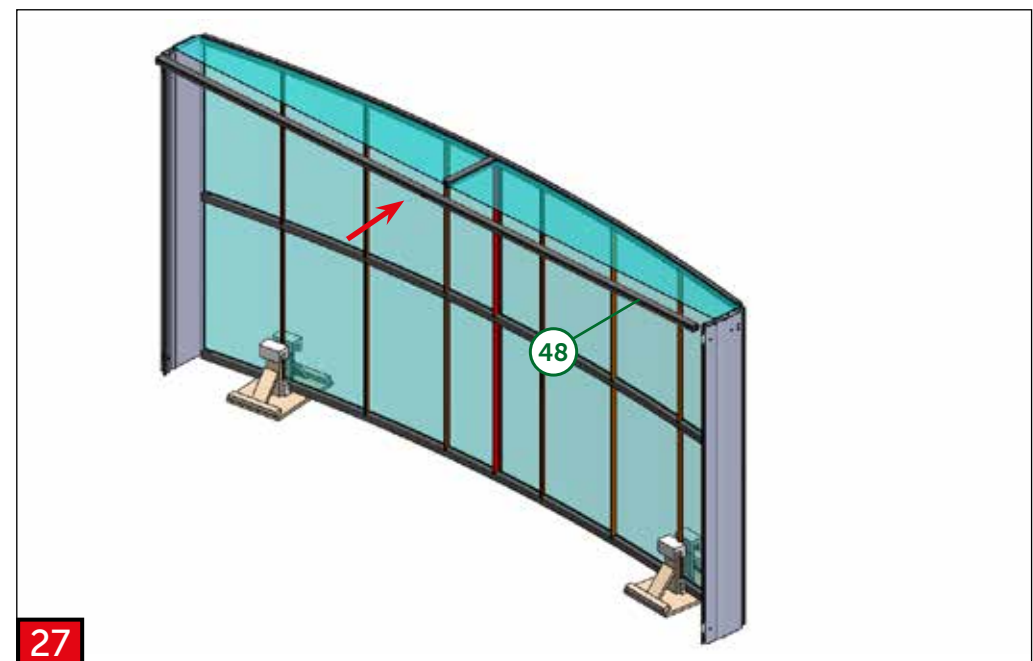

27

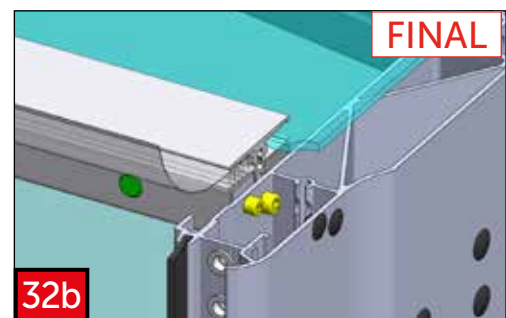
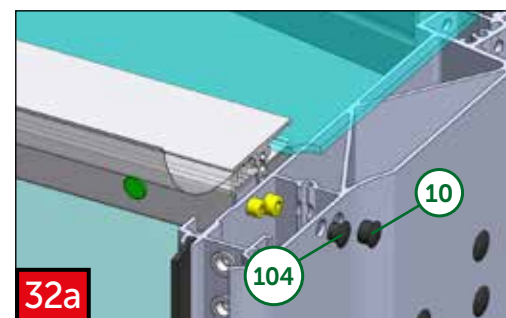
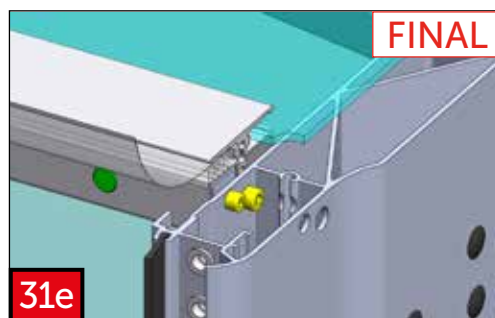
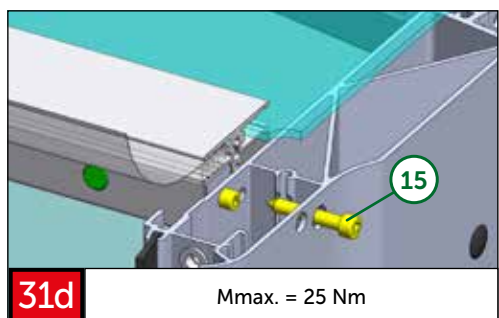
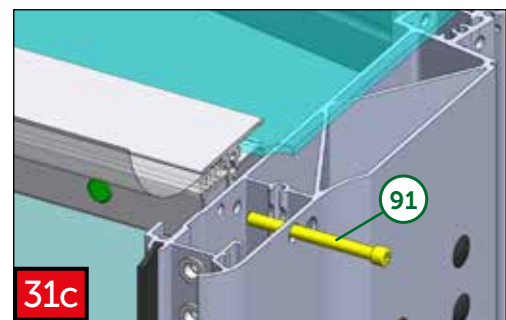
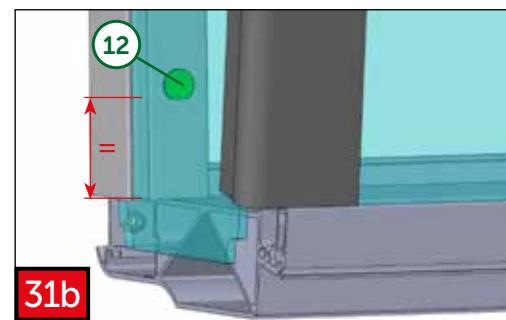
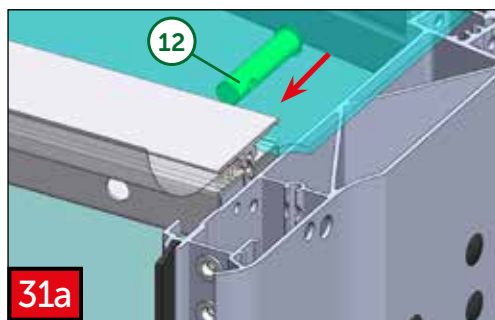
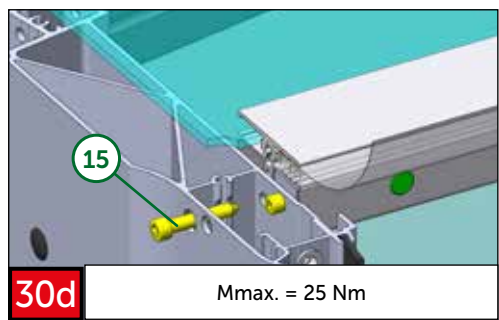
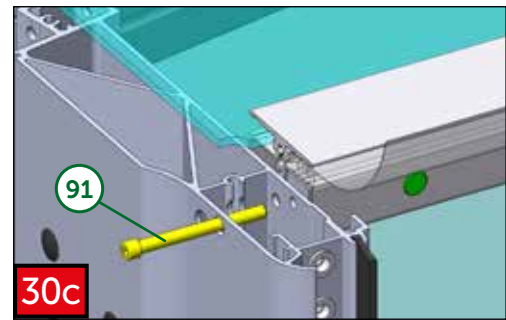
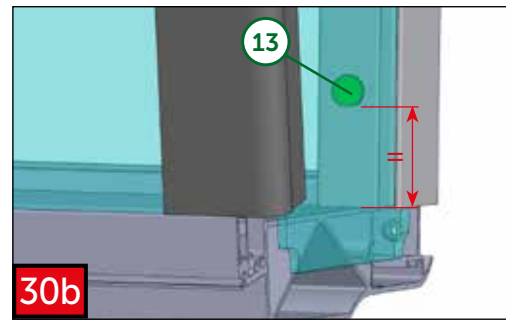
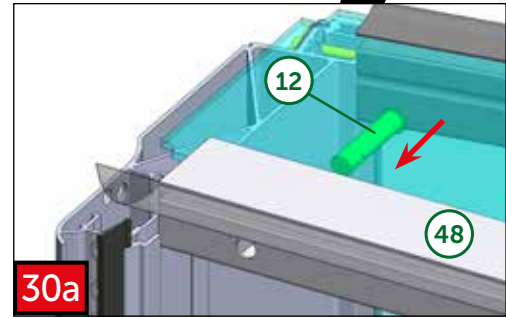
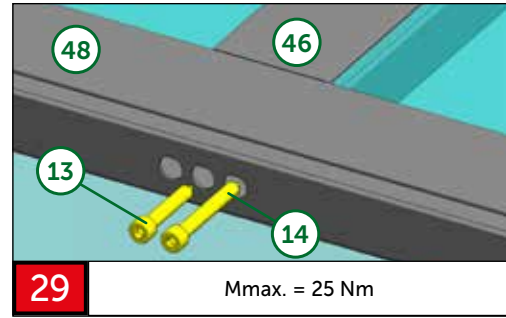
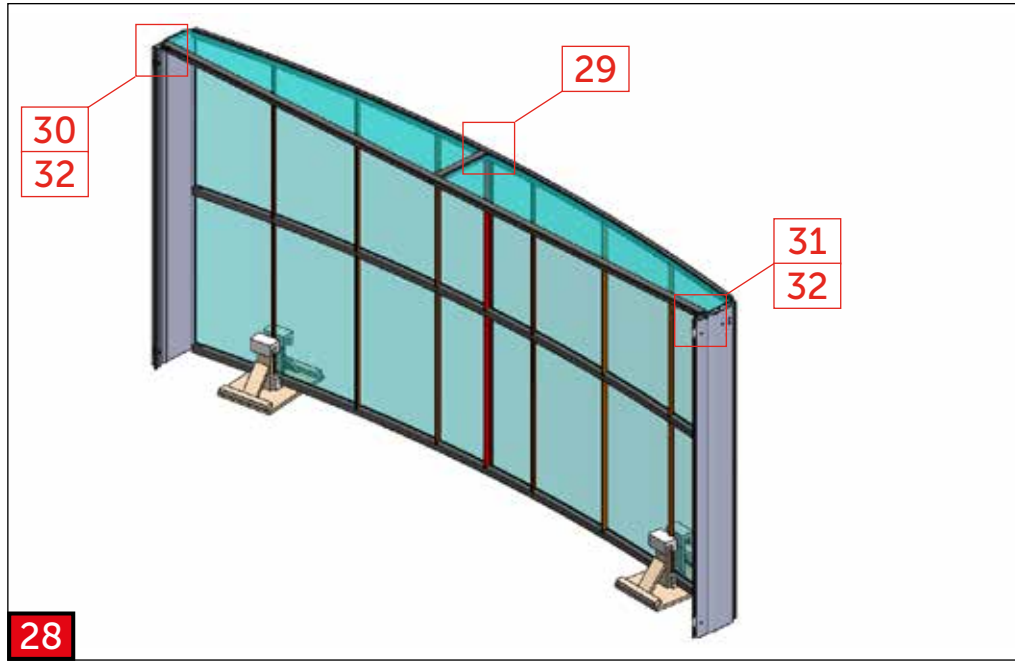

⚠ only SYDNEY CLEAR ⚠

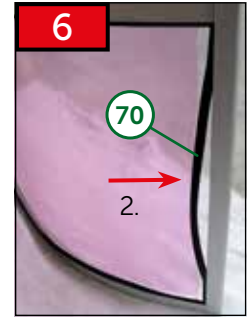
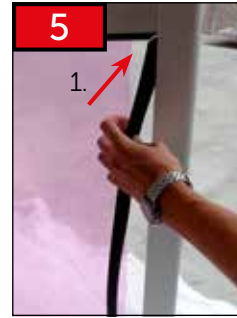
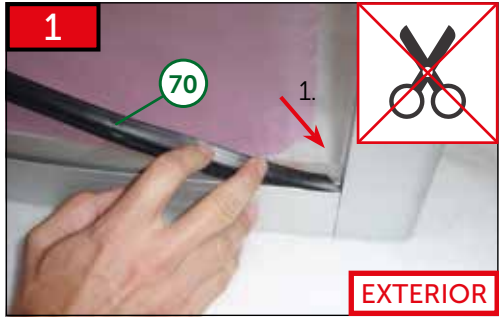
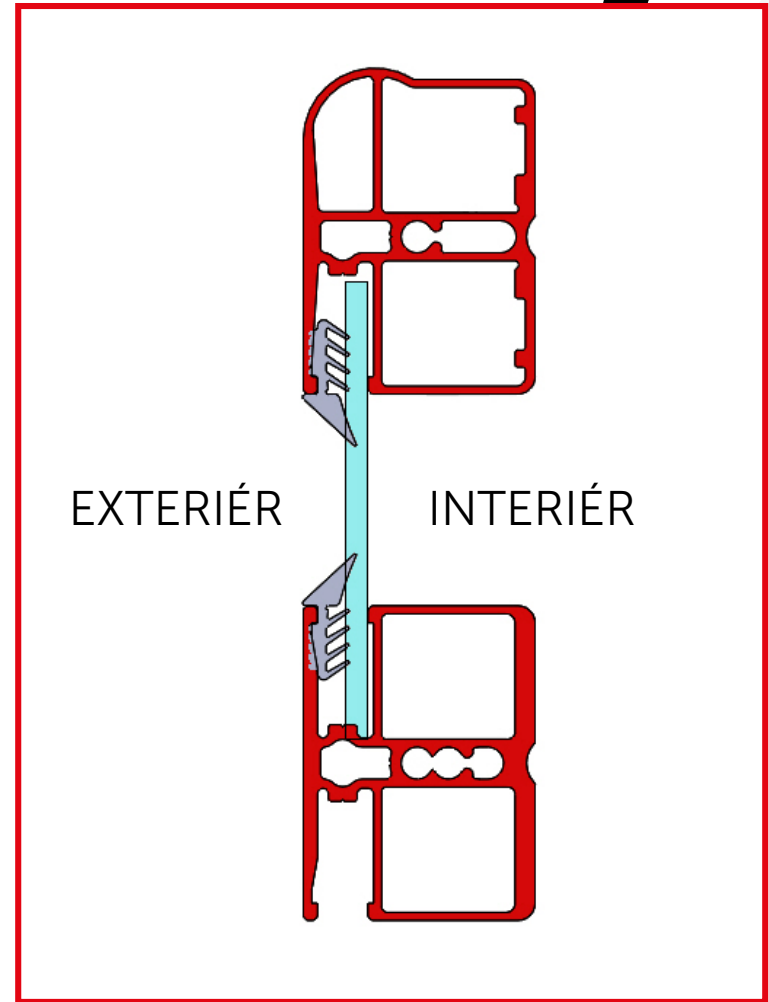
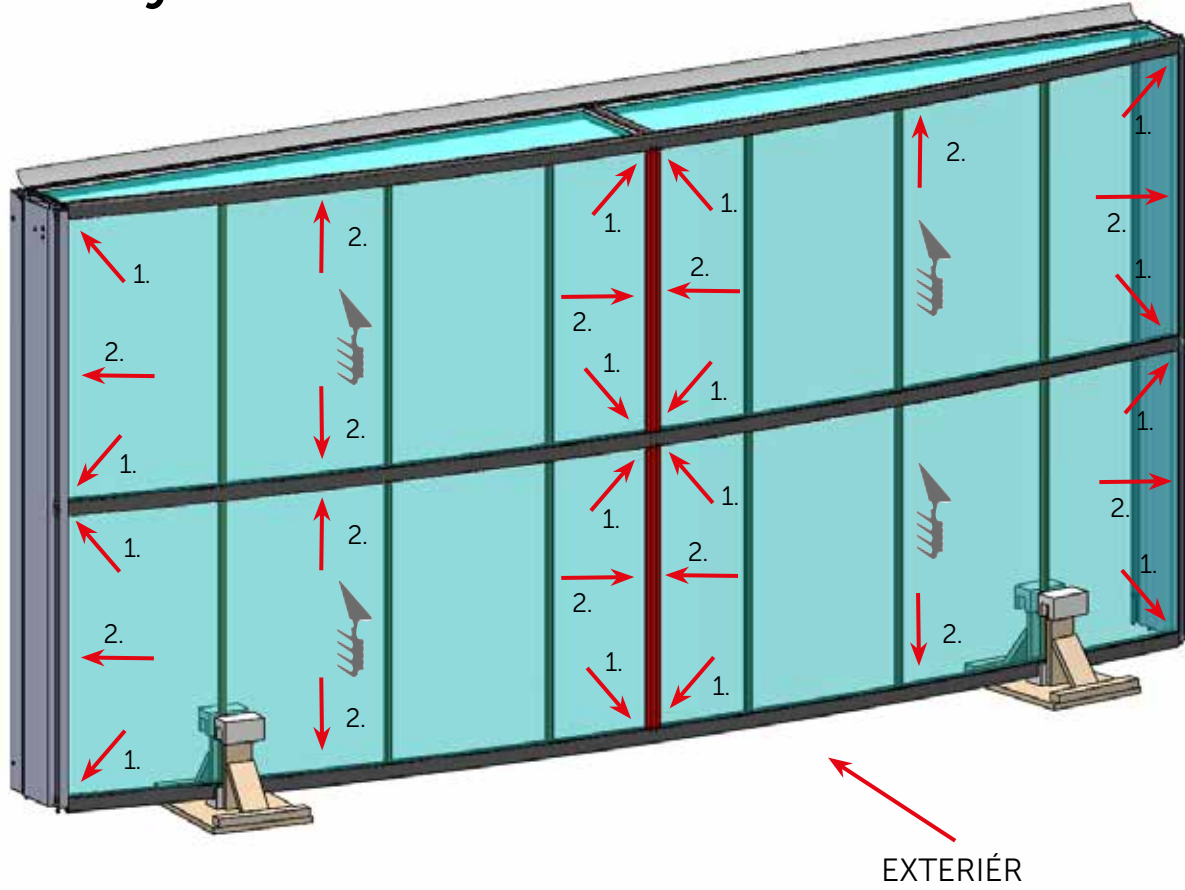

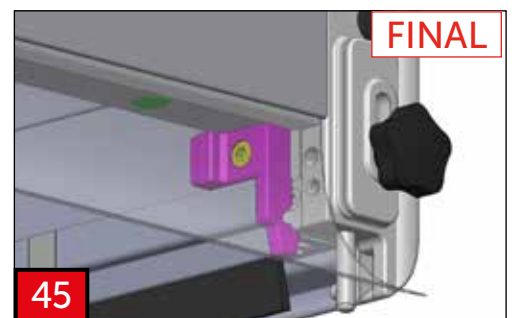
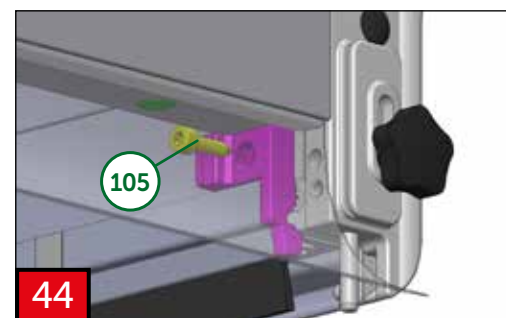
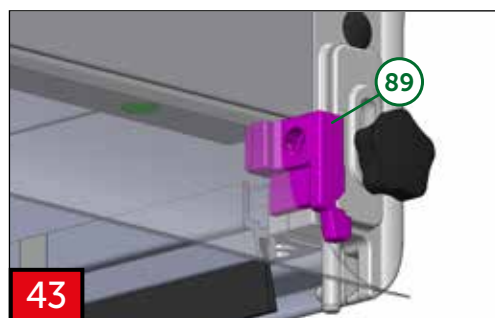
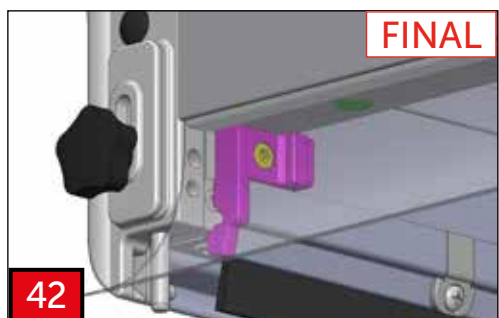
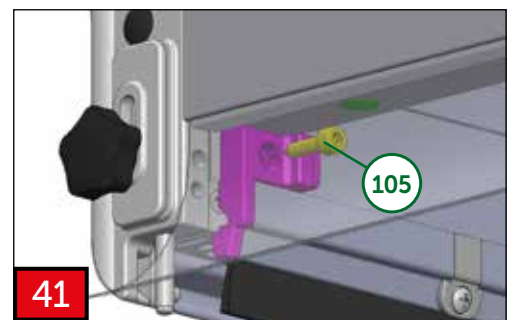
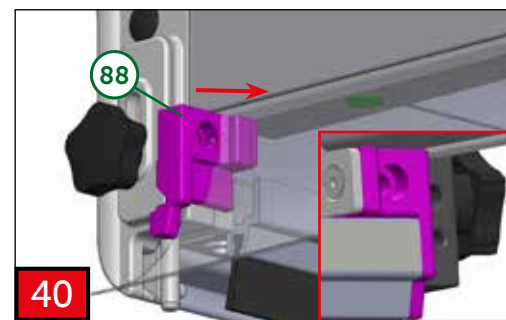
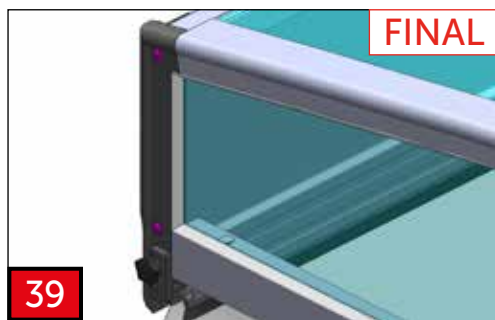
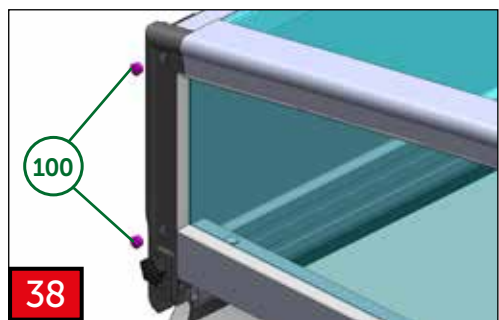
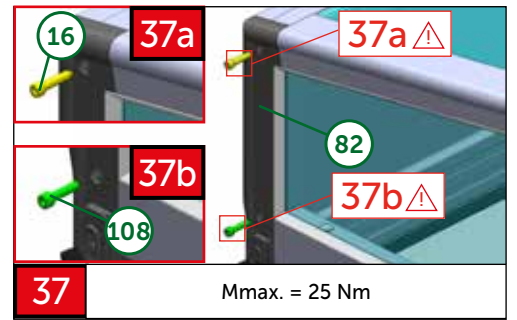
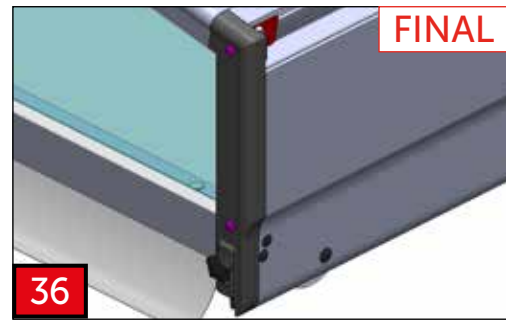
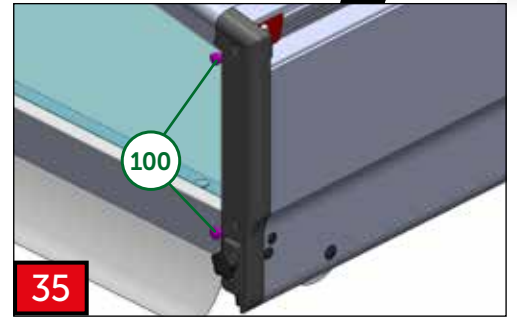
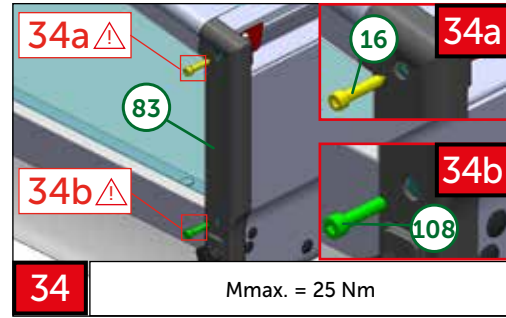
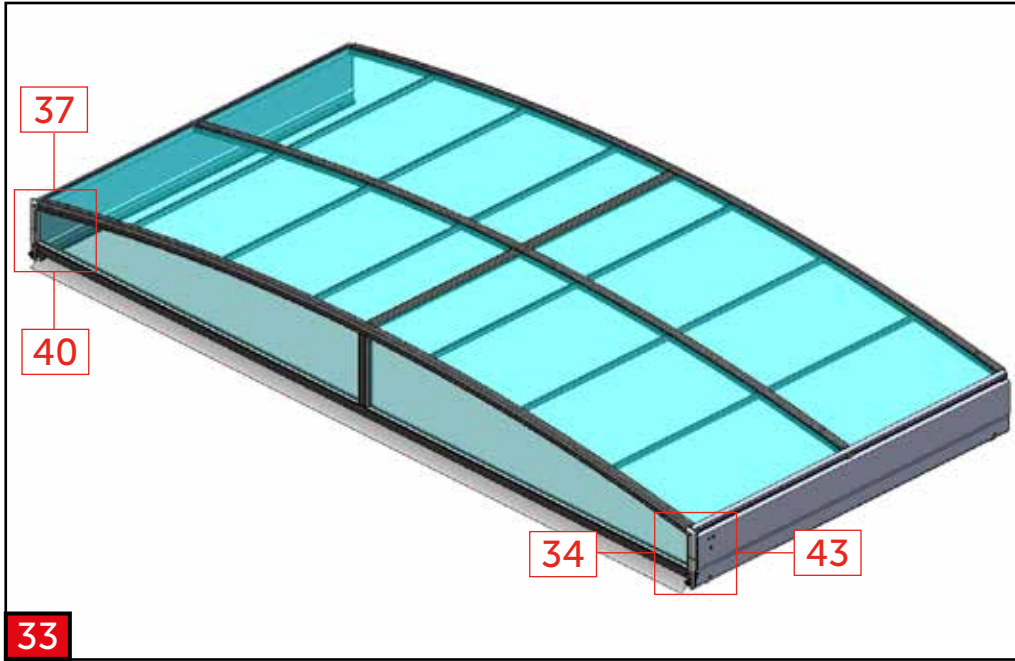

⚠ only SYDNEY CLEAR ⚠

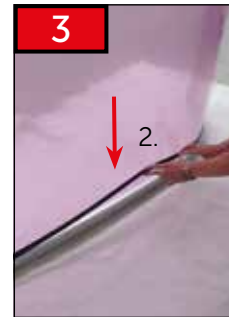
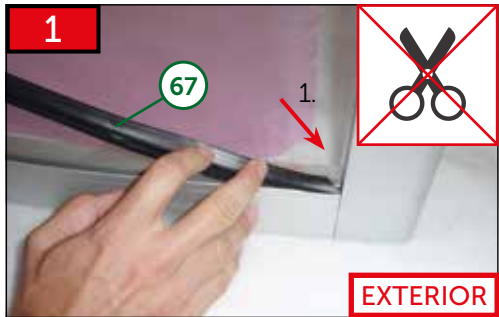
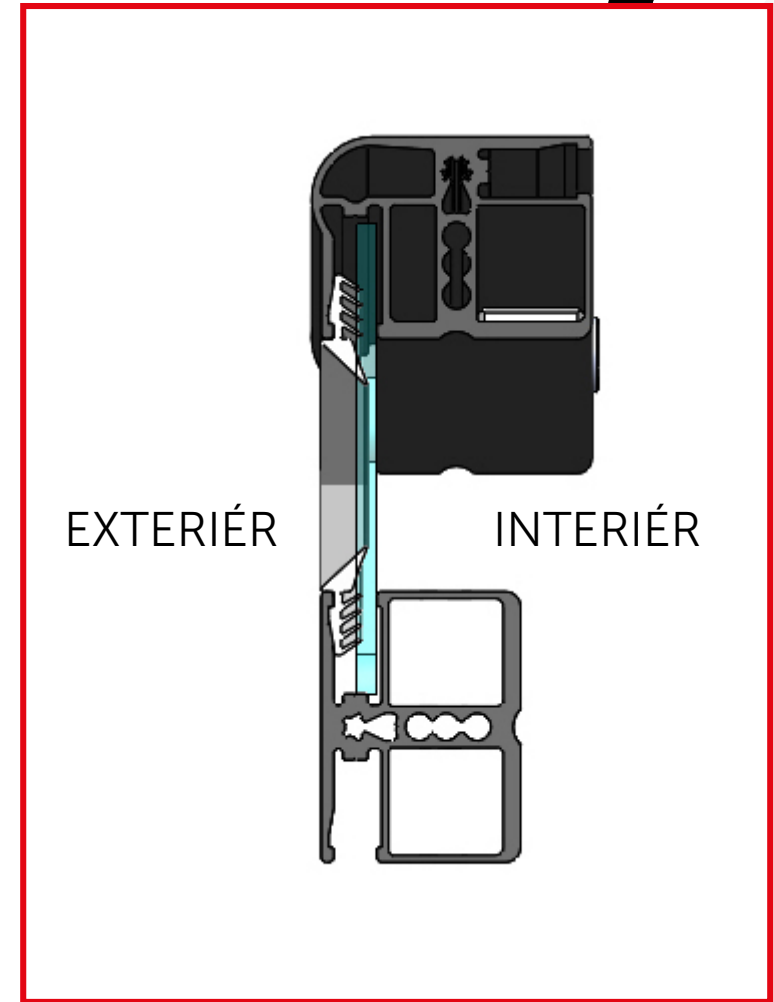
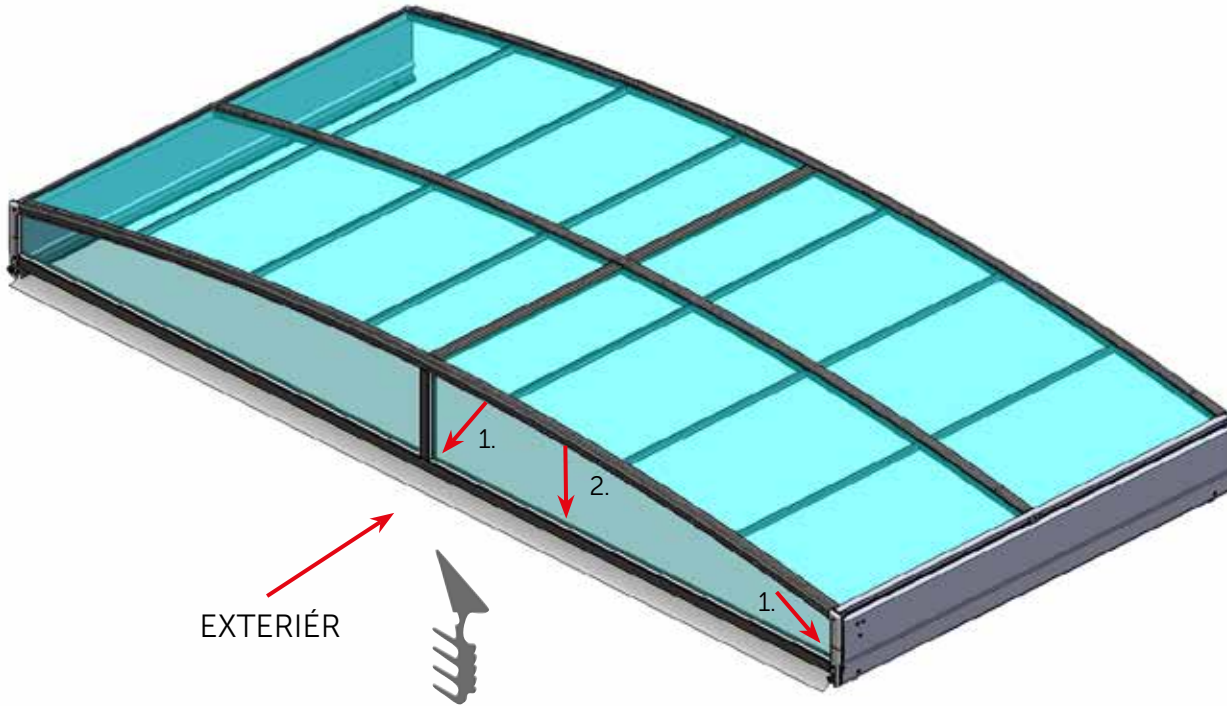

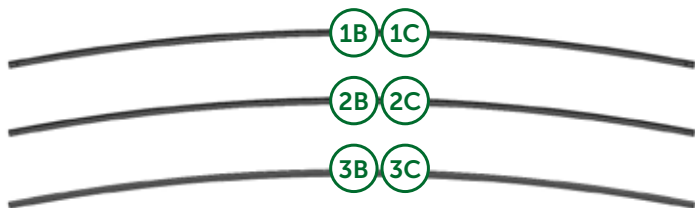

1SP07-01-001

ø4 x 10

28x

7

1SP11-01-031

AN 9051

6,3 x 70

8x

14

1SP11-01-053

AN 9051

6,3 x 32

6x

16

1NA03-01-050

1x

17

Sydney C/ Clear C 2Z04-01-SD002 1032mm

12x

36

Sydney C/ Clear C 2Z05-01-SD003 1032mm

2x

37

Sydney C/ Clear C 2Z02-09-SD027 2150 mm

2x

58

1SP10-01-084

ISO 7380

M 6x20

2x

92

1SZ18-02-009

2x

93

1SZ18-02-012

4x

94

1SP11-01-049

AN 9051

4,8x60

6x

95

1SP10-01-078

DIN 912

M 6x65

4x

96

1SP10-01-082

DIN 912

M 6x100

6x

97

1SZ03-01-029

2x

98

1SZ03-01-030

4x

99

1SZ12-01-010

8x

100

1SP10-01-025

DIN912

M6x25

2x

108

MODUL B Sydney C/ Clear C 2Z02-09-OSR021 2150 mm

"KL" = "KP"

1x

54

MODUL B Sydney C/ Clear C 2Z02-09-OSR022 2150 mm

"KL" = "KP"

1x

55

MODUL C Sydney C/ Clear C 2Z02-09-OSR023 2150 mm

"KL" = "KP"

1x

52

MODUL C Sydney C/ Clear C 2Z02-09-OSR024 2150 mm

"KL" = "KP"

1x

53

Sydney C/ Clear C	2373 x 1042 mm	MODUL B
-------------------	----------------	---------

4x

61

Sydney C/ Clear C	2432 x 1042 mm	MODUL C
-------------------	----------------	---------

4x

62

MODUL B	2Z09-01-SD072
---------	---------------

1x

76

MODUL B	2Z09-01-SD073
---------	---------------

1x

77

MODUL B	2Z09-01-SD074
---------	---------------

1x

78

MODUL B	2Z09-01-SD075
---------	---------------

1x

79

MODUL C	2Z09-01-SD058
---------	---------------

1x

80

MODUL C	2Z09-01-SD059
---------	---------------

1x

81

MODUL C	2Z09-01-SD060
---------	---------------

1x

82

MODUL C	2Z09-01-SD061
---------	---------------

1x

83

MODUL B	1x
MODUL C	1x

1SZ18-02-001D

OPTIONAL "KL"

3

MODUL B	1x
MODUL C	1x

1SZ18-02-002D

OPTIONAL "KP"

4

Pomocný držák pro montáž modulu
Auxiliary holder for the assembly of module
Zusätzliche Halterung für die Modulmontage
Support auxiliaire pour l'assemblage du module
Вспомогательный держатель для сборки модуля



Nutné zajistit modul proti překlopení. Doporučujeme vyrobit držák z balení (prkna + výložky) nebo zajistit jiným způsobem.

The module must be secured against falling. We recommend that you make a holder from the transport box (boards + foam liner) or that you secure the module in other safe way.

Das Modul muss gegen Umkippen gesichert werden. Wir empfehlen, einen Halter aus der Verpackung (Bretter + Liner) zu machen oder das Modul auf andere Weise zu sichern.

Il est nécessaire d'assurer le module contre son renversement. Nous recommandons de fabriquer le support de l'emballage (les planches + les parements) ou de l'assurer autrement.

Необходимо обезопасить модуль от опрокидывания. Мы рекомендуем сделать держатель из упаковки (доски + вкладыши) или закрепить его другим способом.

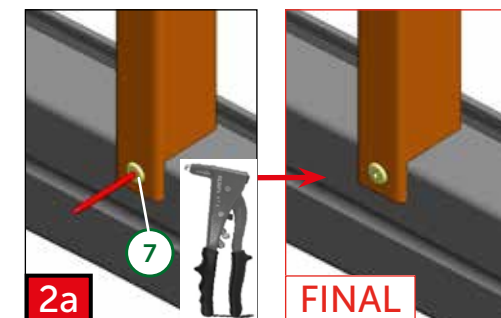
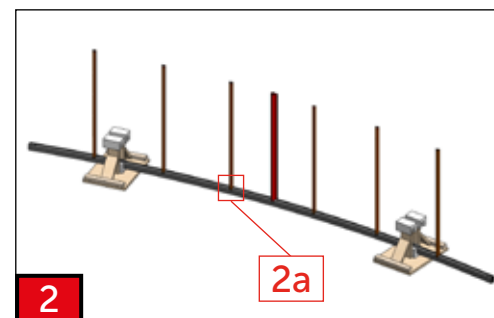
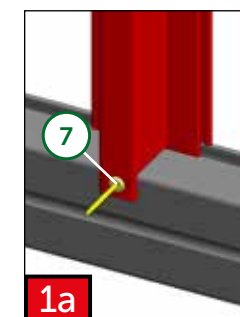
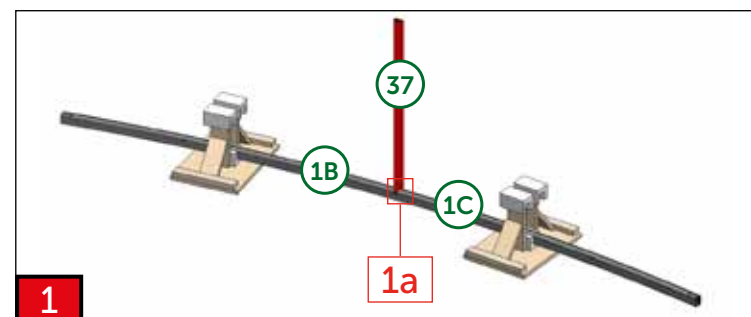
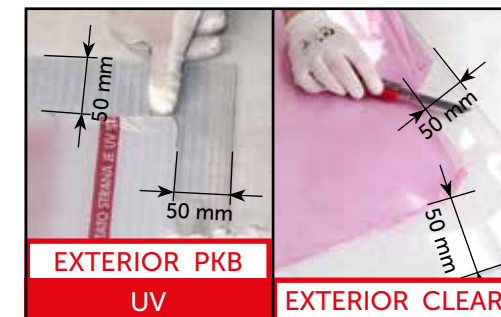
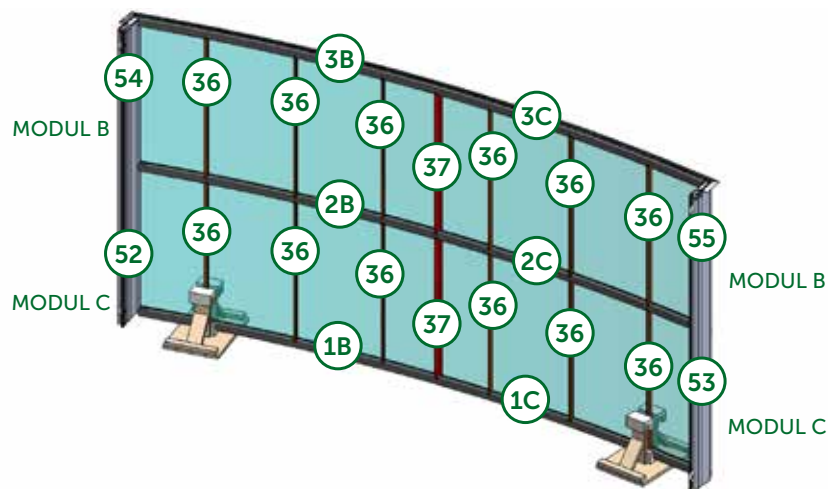
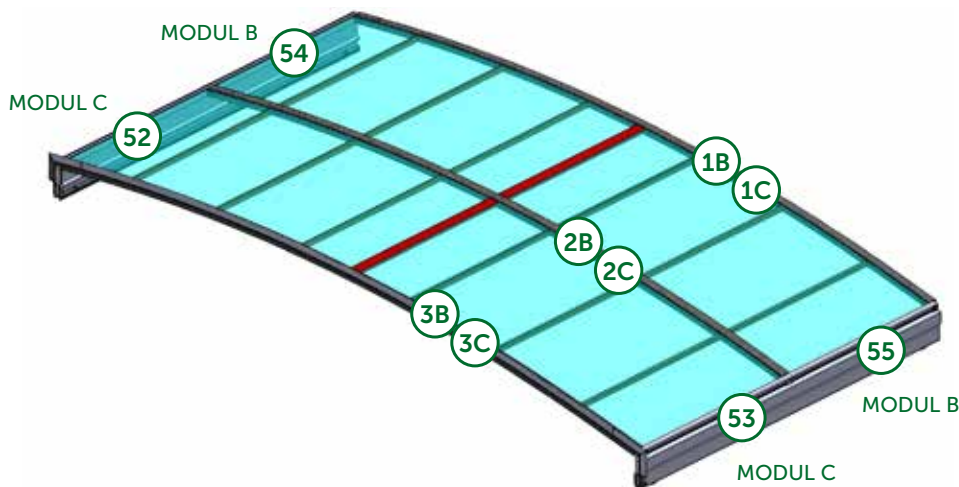
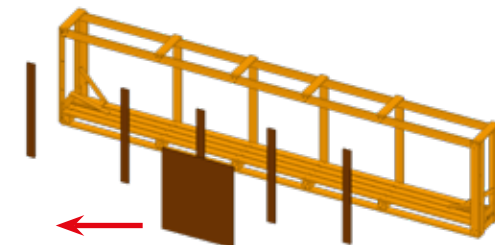

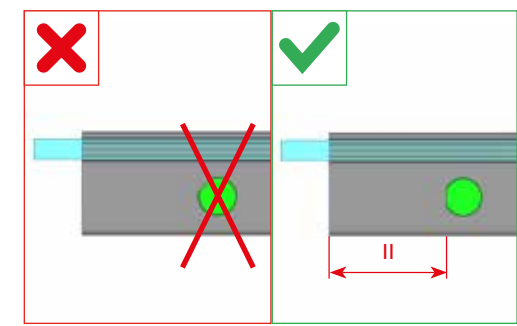
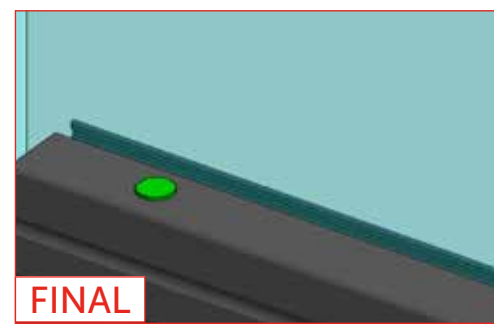
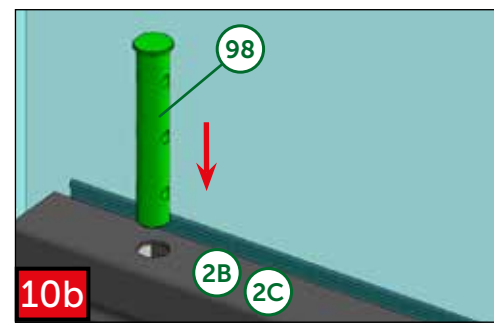
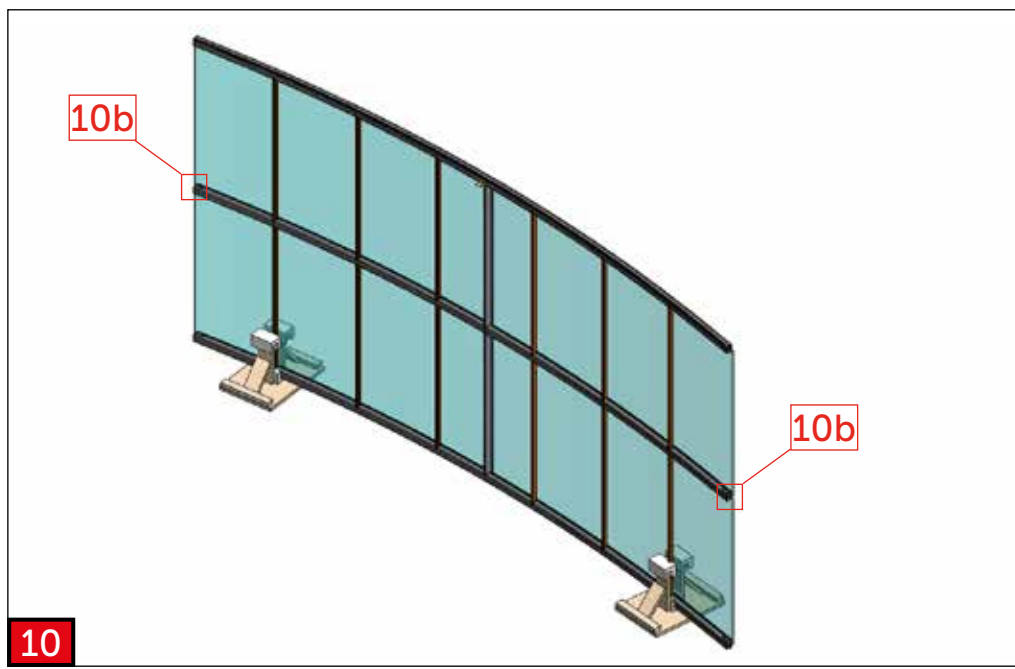
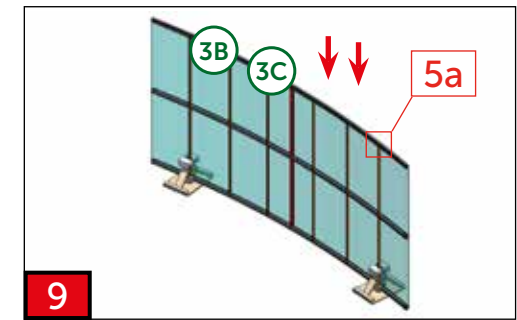
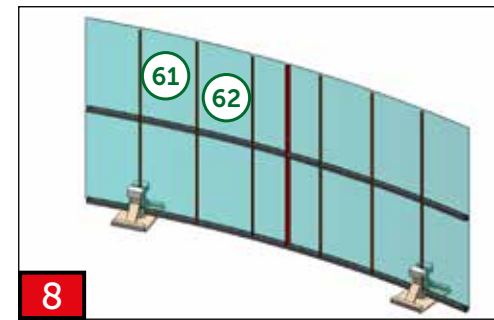
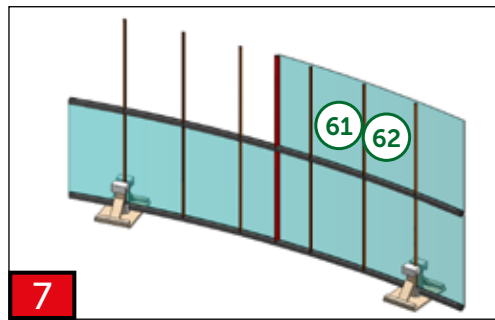
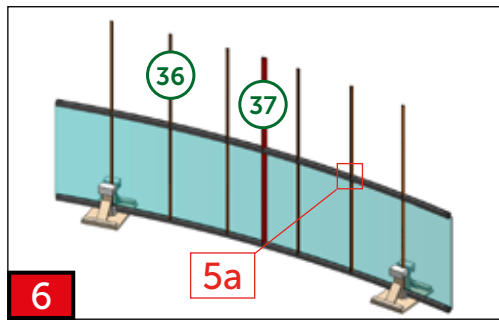
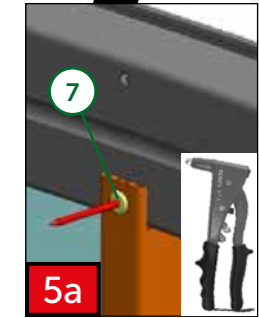
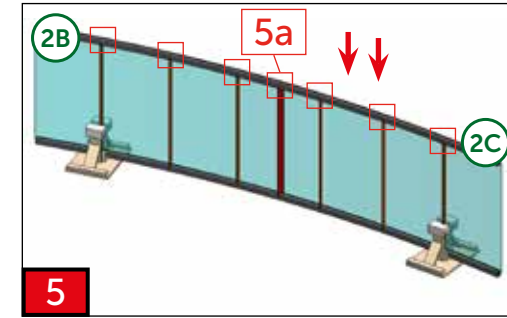
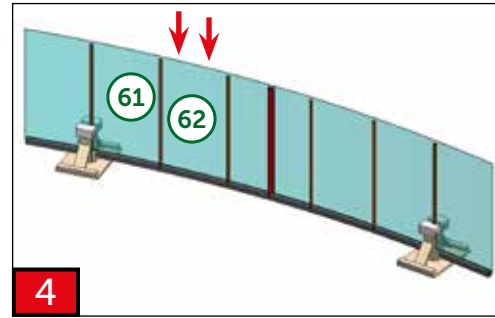
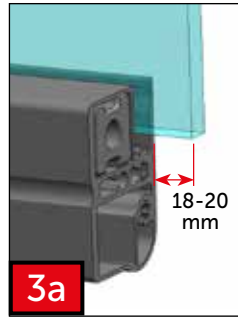
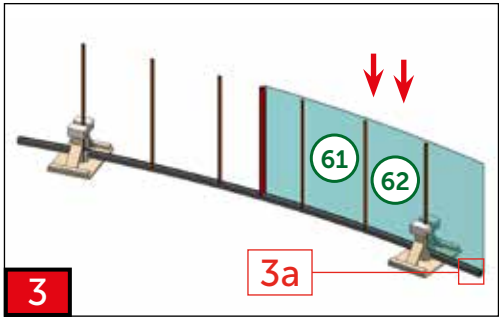

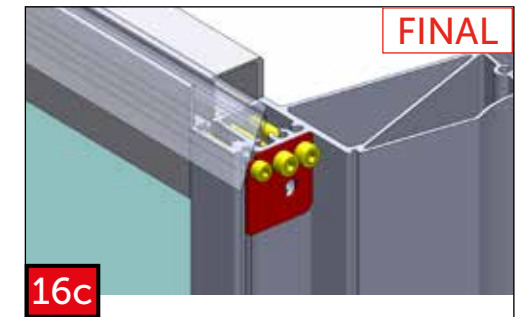
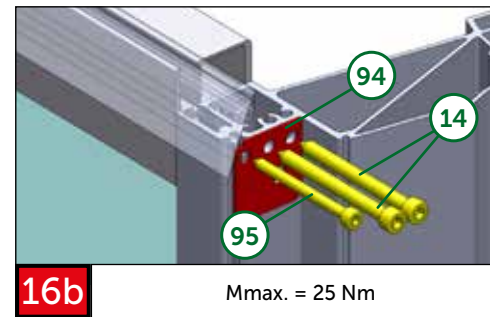
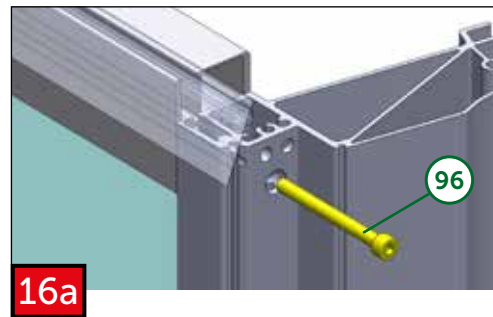
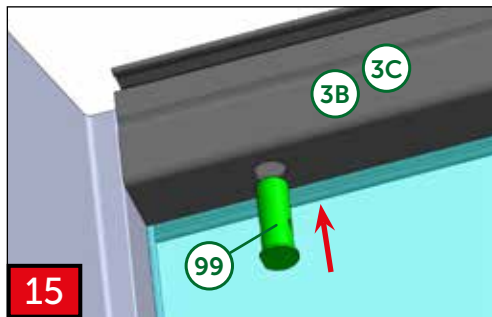
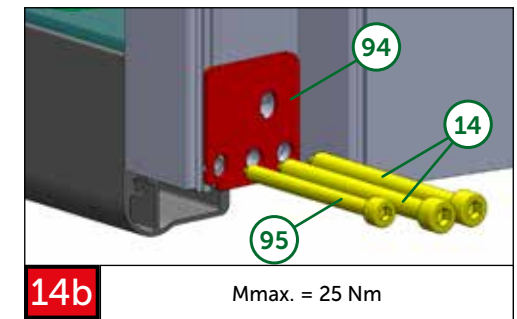
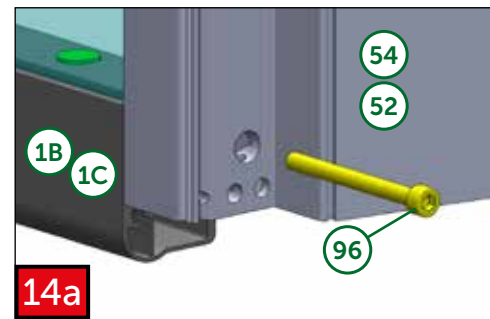
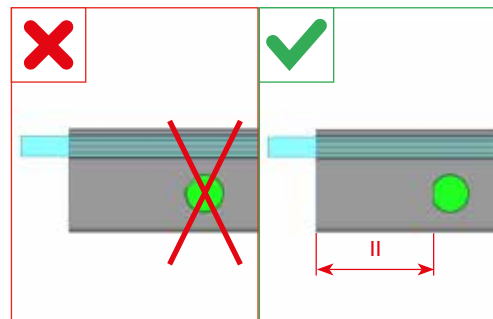
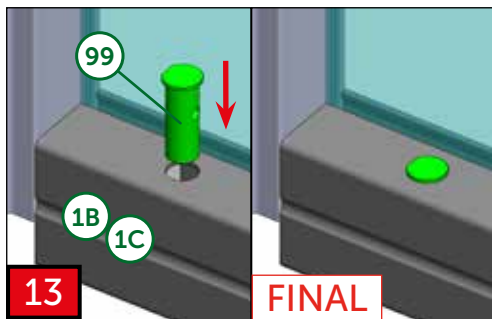
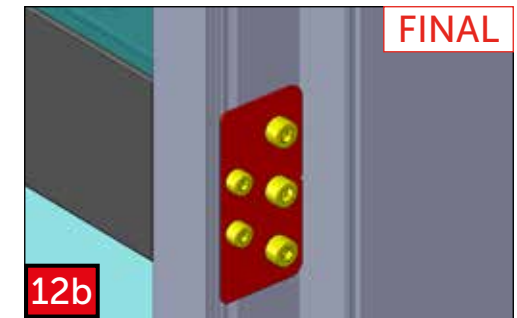
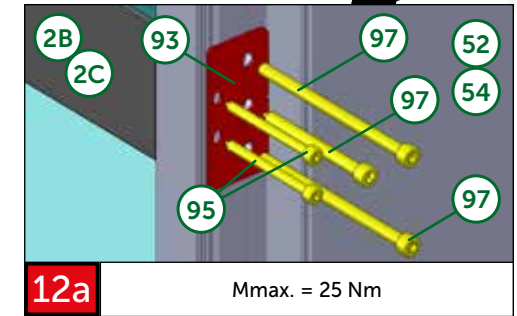
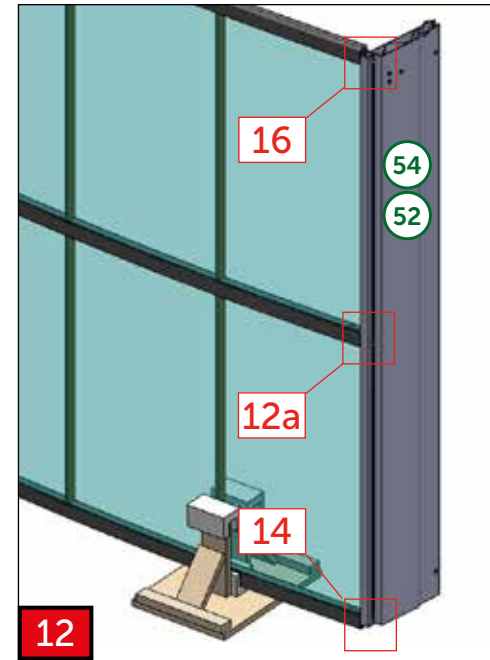
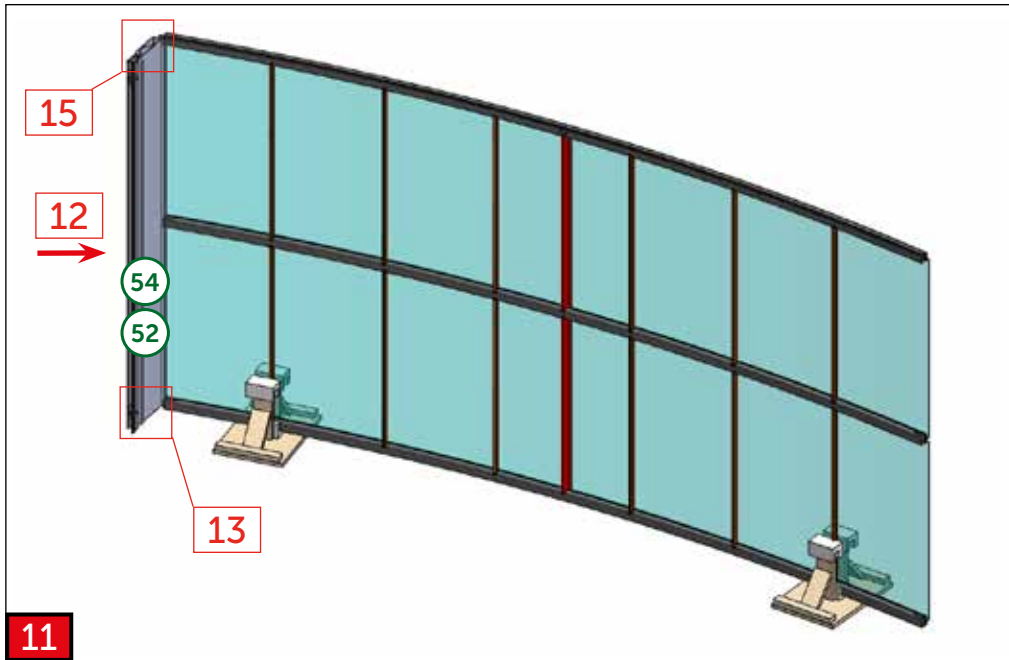

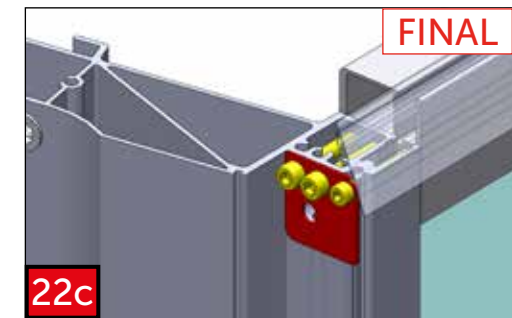
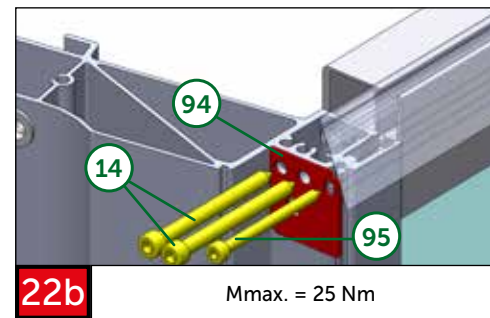
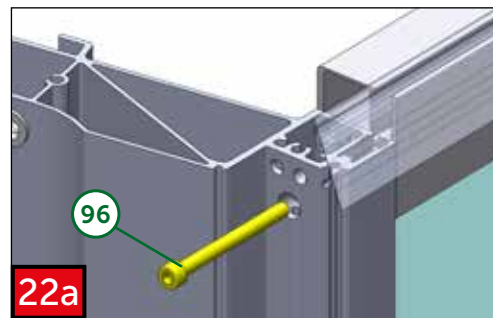
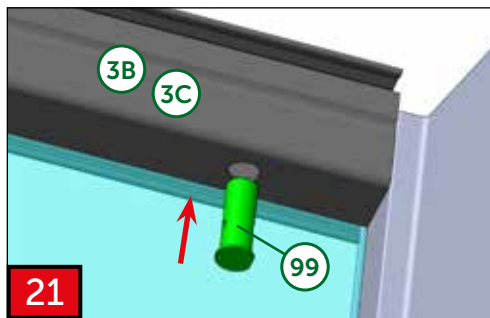
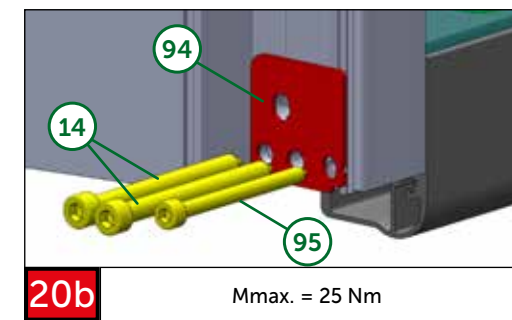
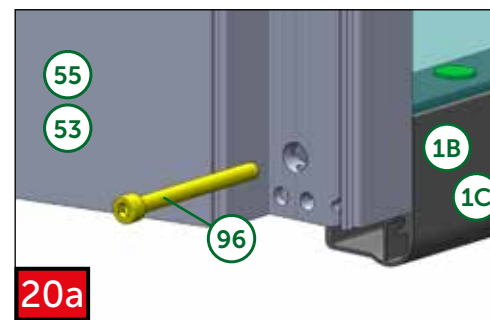
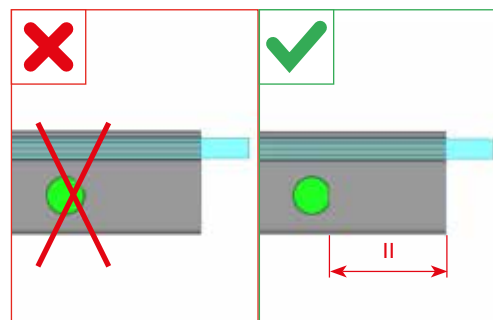
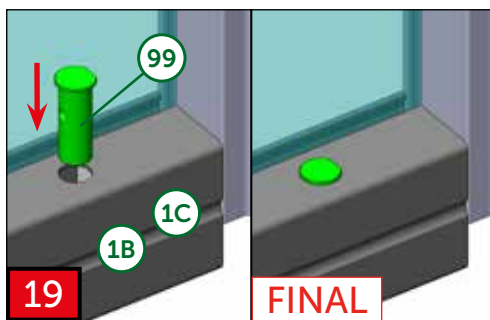
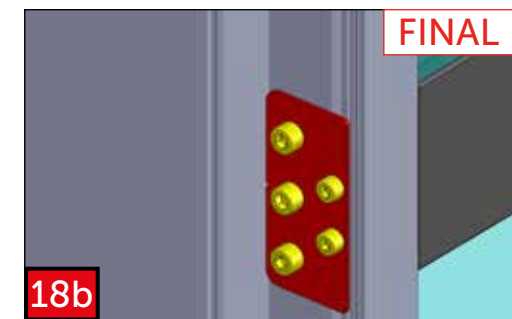
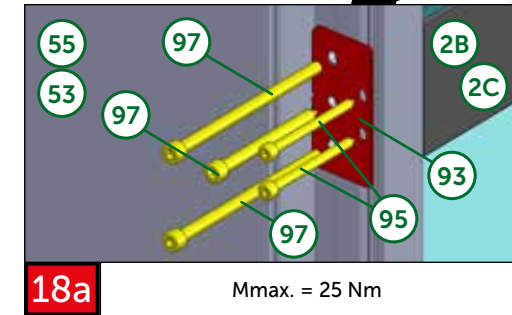
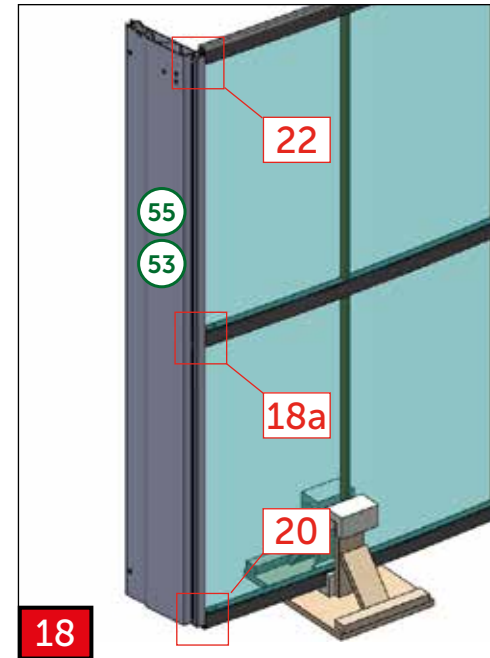
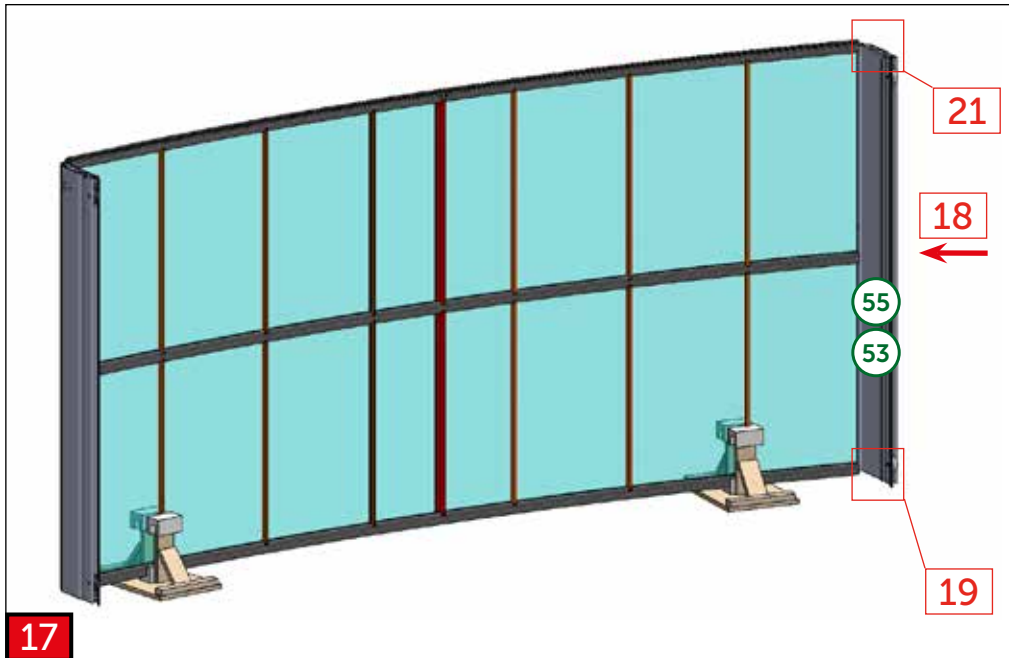

⚠ only SYDNEY CLEAR ⚠

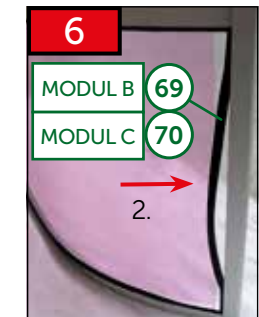
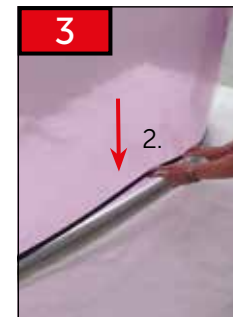
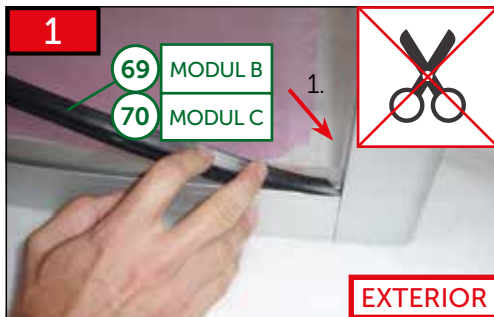
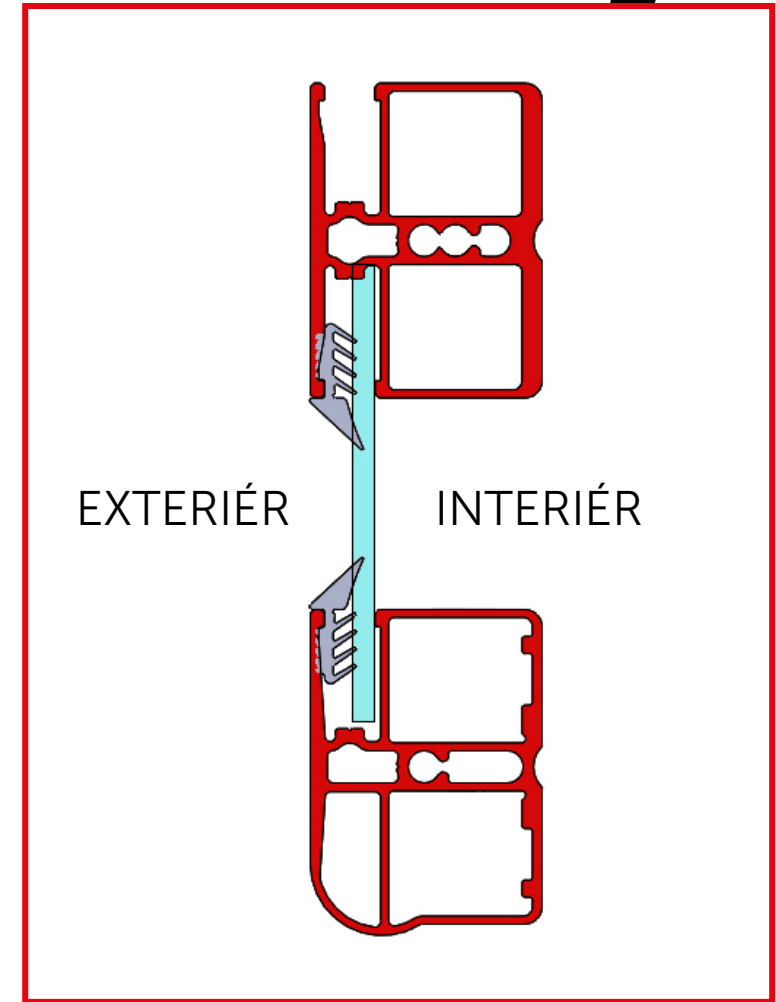
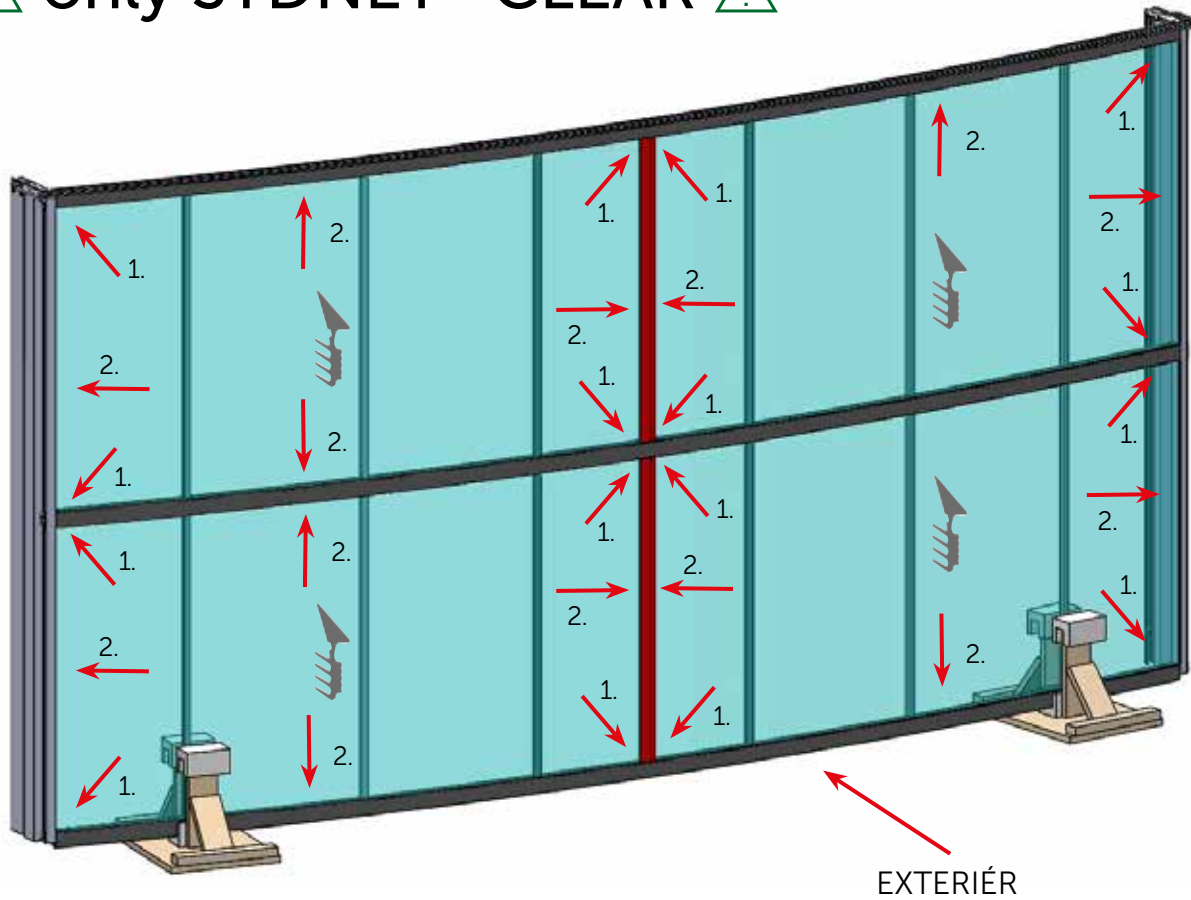

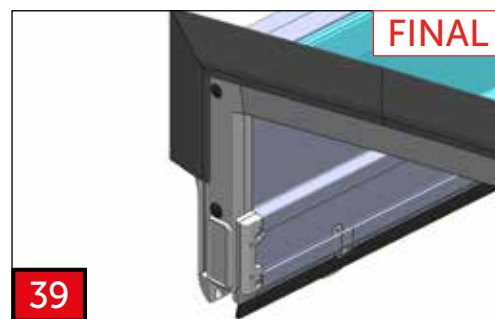
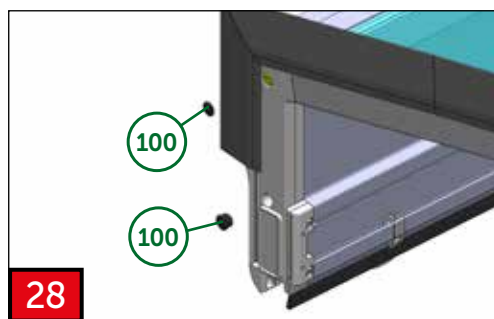
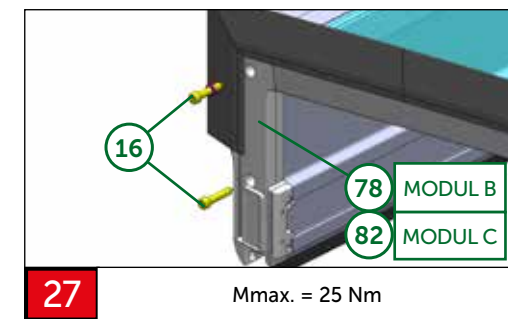
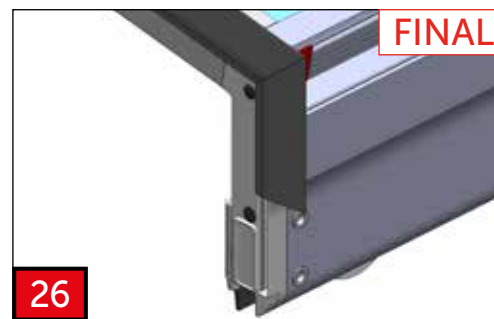
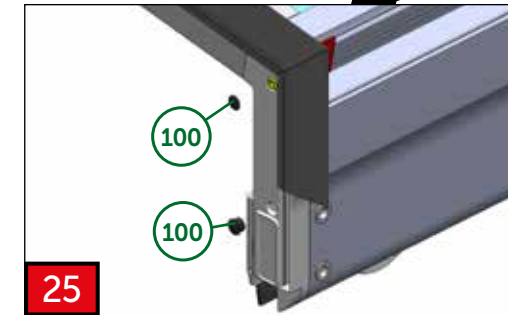
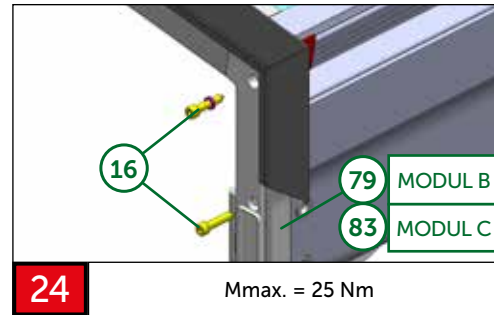
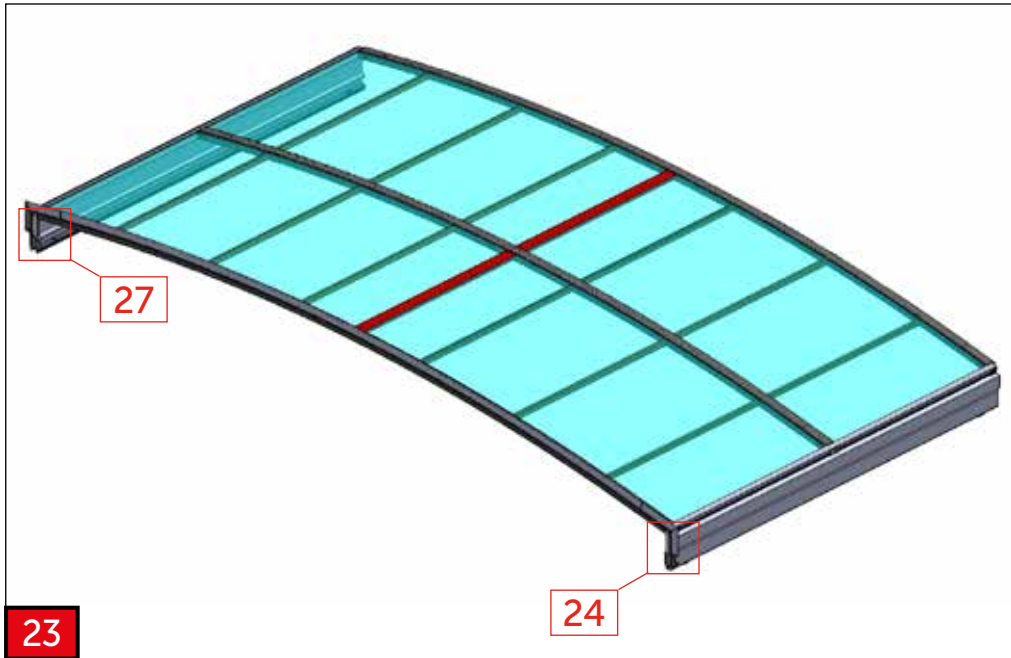

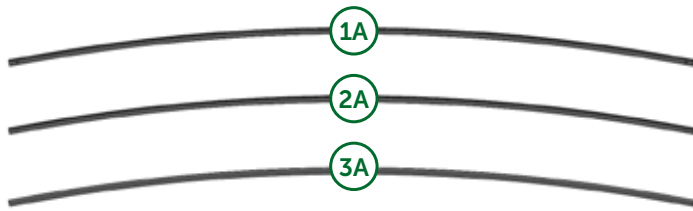

1SP07-01-001

ø4 x 10

20x

7

1SZ03-01-035

DIN 914

M6x14

2x

8

1SZ29-01-008

2x

11

1SZ03-01-040

2x

12

1SP11-01-029

AN 9051

6,3 x 50

1x

13

1SP11-01-031

AN 9051

6,3 x 70

9x

14

1SP11-01-027

AN 9051

6,3 x 38

2x

15

1SP11-01-053

AN 9051 A4

6,3 x 32

6x

16

1NA03-01-050

1x

17

Sydney C/ Clear C 2Z04-01-SD002 1032mm

12x

36

Sydney C/ Clear C 2Z05-01-SD003 1032mm

2x

37

2Z12-04-DP020

237 mm

1x

45

2Z12-04-019

4549 mm

1x

47

"KL" = "KP"

Sydney C/ Clear C 2Z02-09-SR019 2150 mm

1x

56

"KL" = "KP"

Sydney C/ Clear C 2Z02-09-SR020 2150 mm

1x

57

Sydney C/ Clear C 2Z02-09-SD027 2150 mm

2x

58

Sydney C/ Clear C 2291 x 1042 mm

MODULA

UV

4x

60

2x

64

2x

66

2Z09-01-SD078

MODULA

1x

74

2Z09-01-SD079

MODULA

1x

75



1SP10-01-077

DIN 912
M 5x65

2x

91

1SP10-01-084

ISO 7380
M 6x20

4x

92

1SZ18-02-009

2x

93

1SZ18-02-012

4x

94

1SP11-01-049

AN 9051
4,8x60

6x

95

1SP10-01-078

DIN 912
M 6x65

4x

96

1SP10-01-082

DIN 912
M 6x100

6x

97

1SZ03-01-029

2x

98

1SZ03-01-030

4x

99

1SZ12-01-010

8x

100

1SZ12-01-052

2x

104

1SZ12-01-051

2x

10

1SP10-01-025

DIN912
M6x25

2x

108

2Z09-01-SD076

1x

72

MODULA

2Z09-01-SD077

1x

73

MODULA

1SZ18-02-001D

1x

3

MODULA

1SZ18-02-002D

1x

4

MODULA

Pomocný držák pro montáž modulu
Auxiliary holder for the assembly of module
Zusätzliche Halterung für die Modulmontage
Support auxiliaire pour l'assemblage du module
Вспомогательный держатель для сборки модуля



Nutné zajistit modul proti překlopení. Doporučujeme vyrobit držák z balení (prkna + výložky) nebo zajistit jiným způsobem.
 The module must be secured against falling. We recommend that you make a holder from the transport box (boards + foam liner) or that you secure the module in other safe way.
 Das Modul muss gegen Umkippen gesichert werden. Wir empfehlen, einen Halter aus der Verpackung (Bretter + Liner) zu machen oder das Modul auf andere Weise zu sichern.
 Il est nécessaire d'assurer le module contre son renversement. Nous recommandons de fabriquer le support de l'emballage (les planches + les parements) ou de l'assurer autrement.
 Необходимо обезопасить модуль от опрокидывания. Мы рекомендуем сделать держатель из упаковки (доски + вкладыши) или закрепить его другим способом.

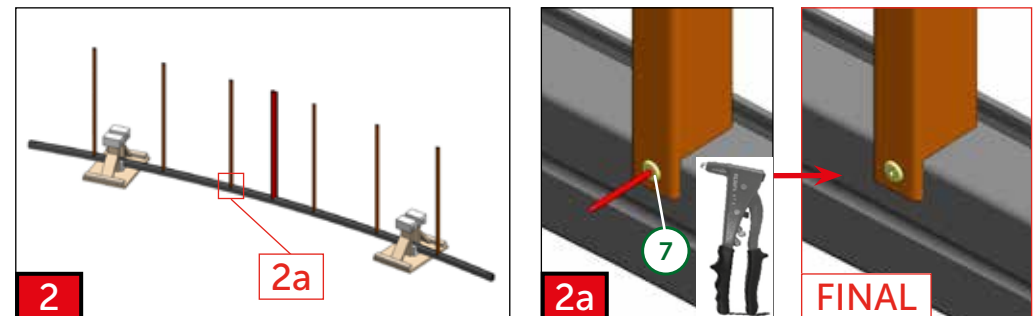
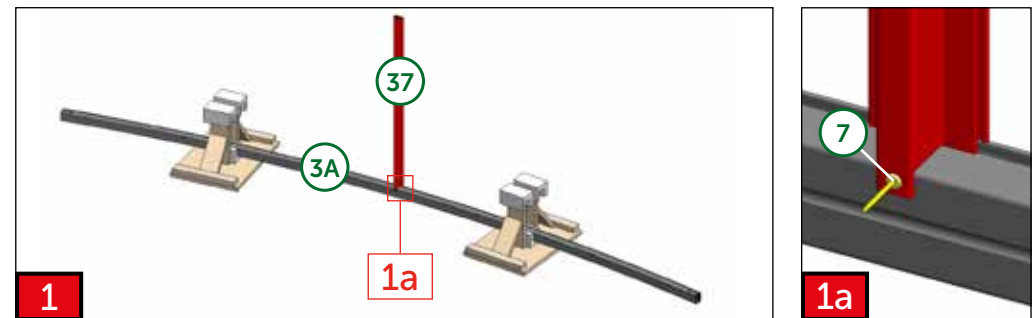
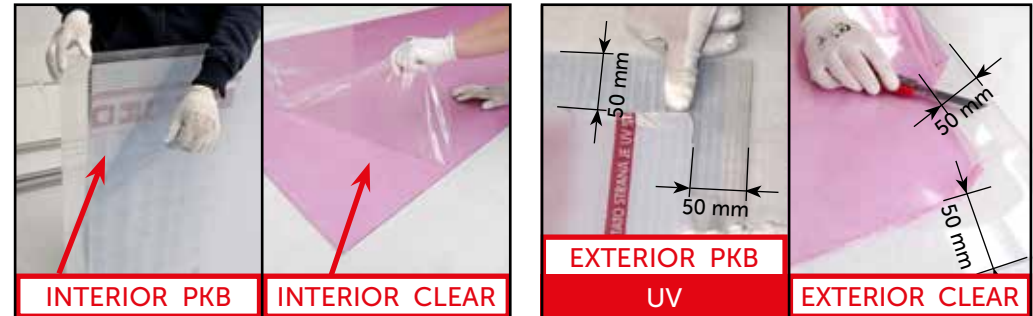
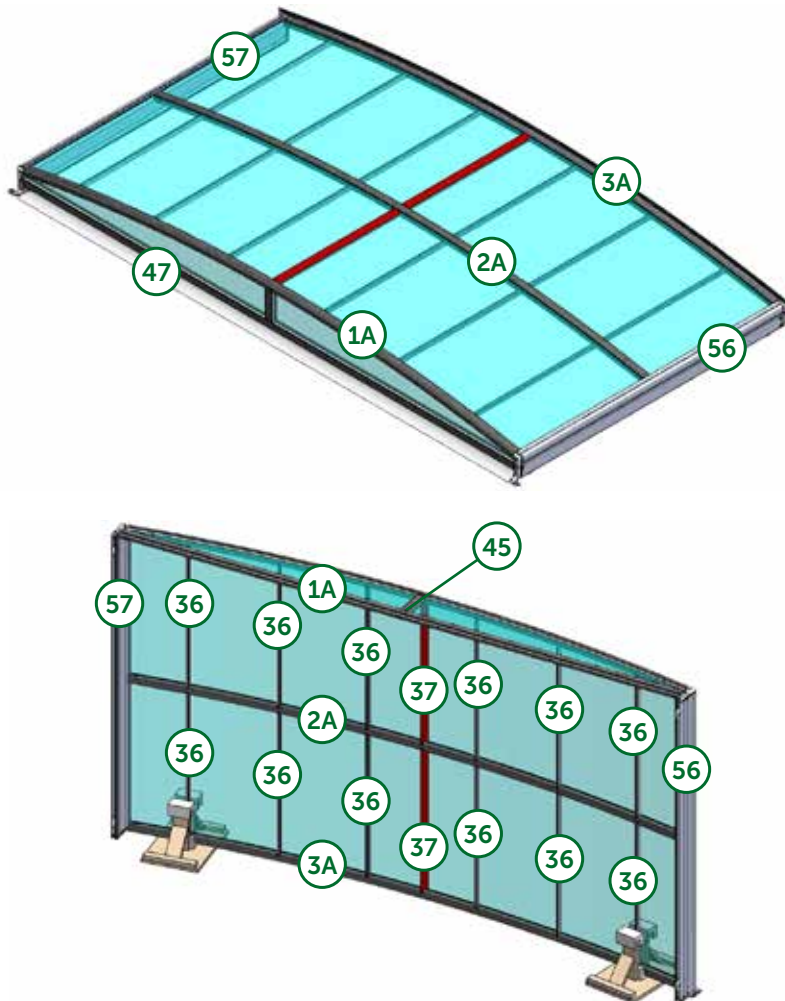
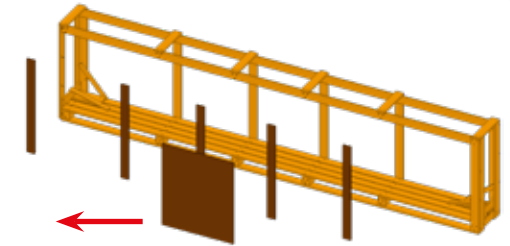

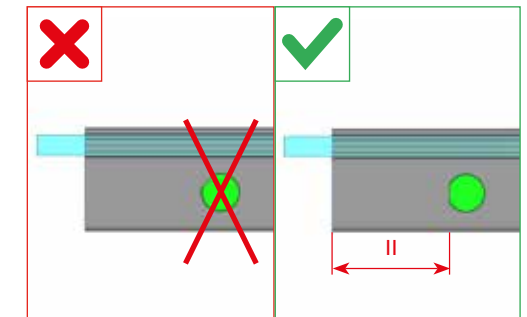
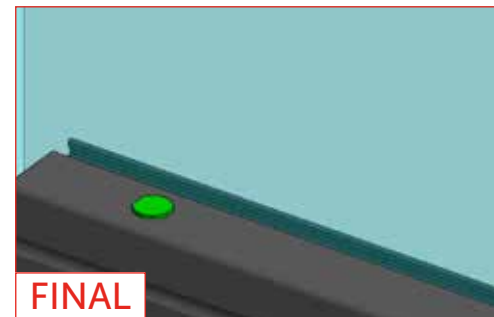
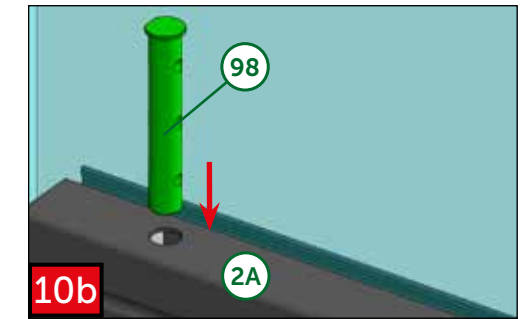
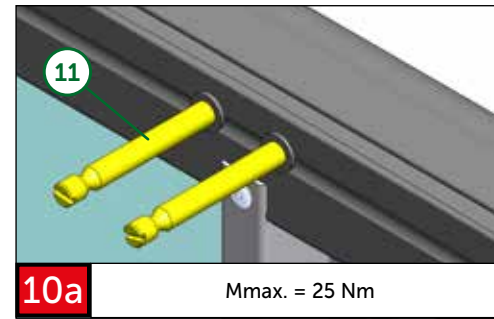
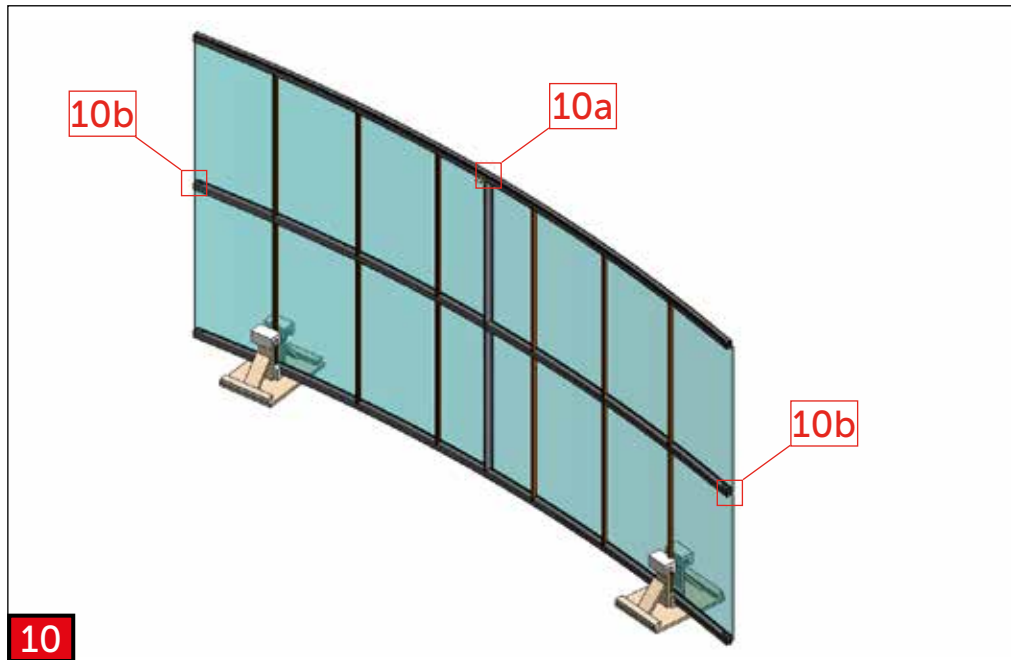
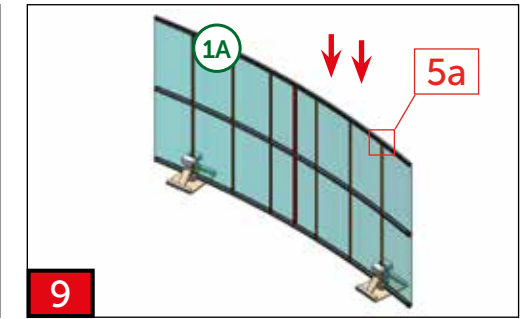
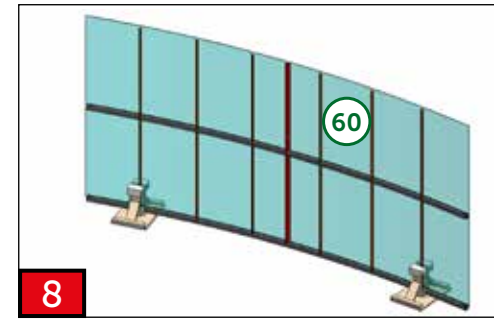
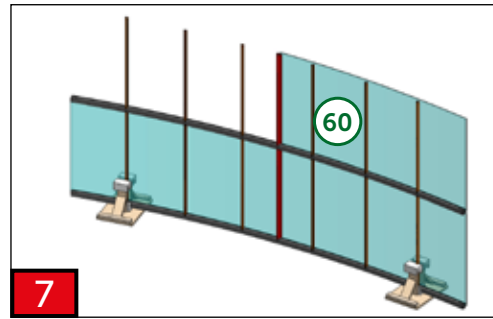
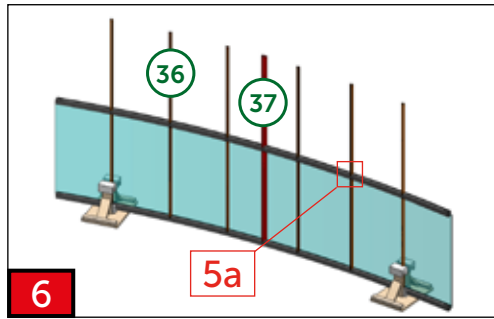
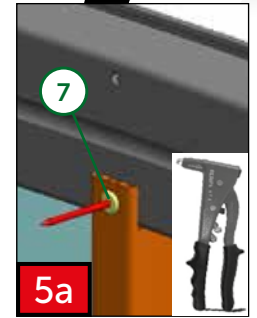
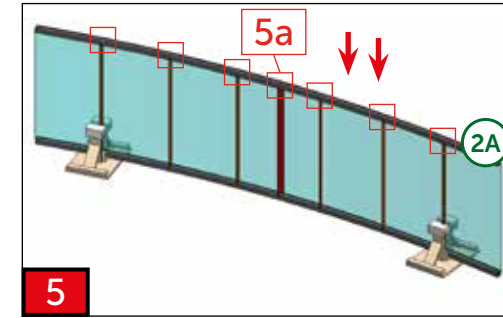
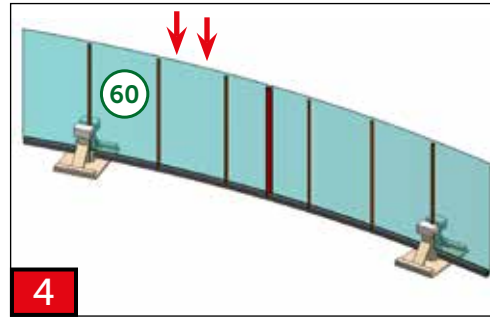
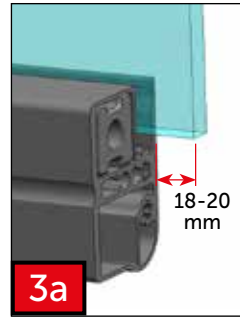
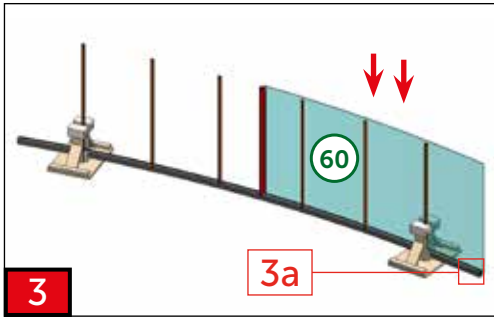

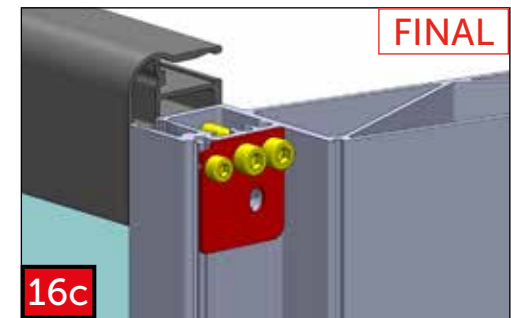
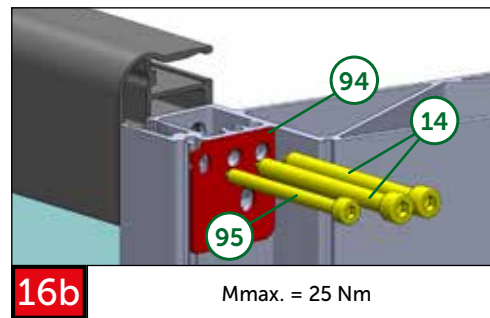
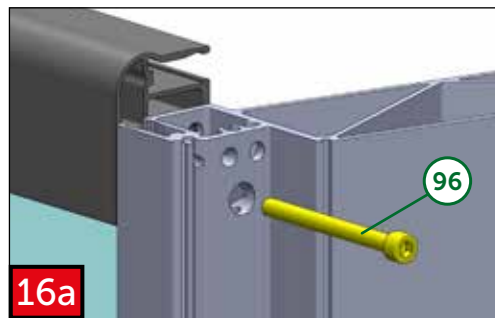
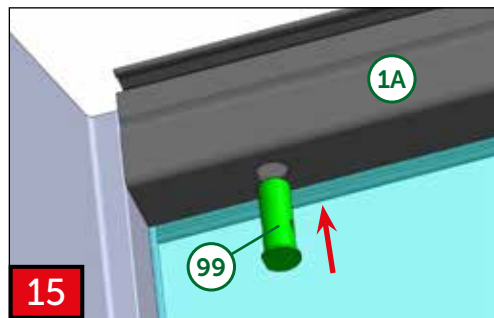
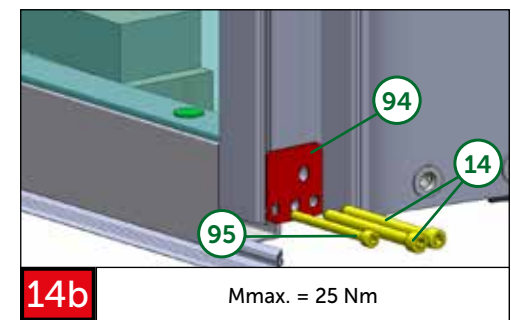
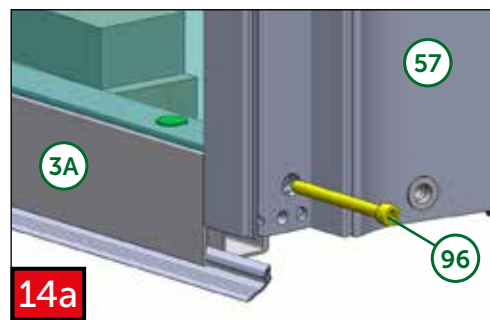
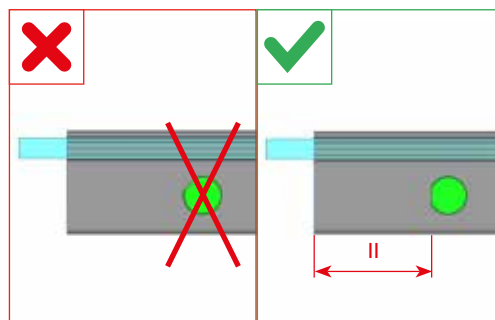
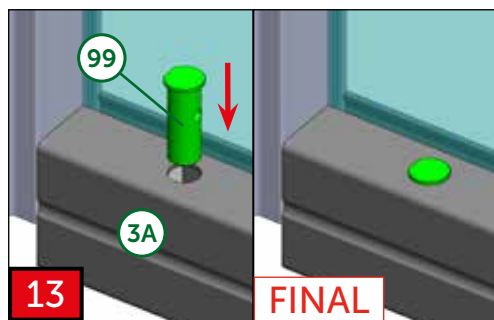
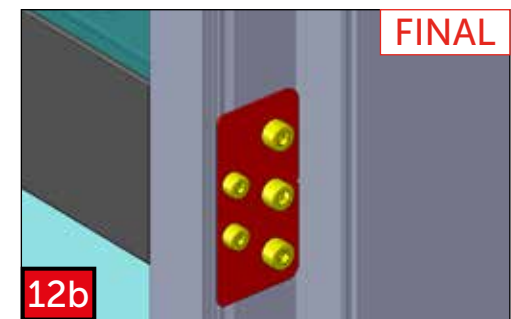
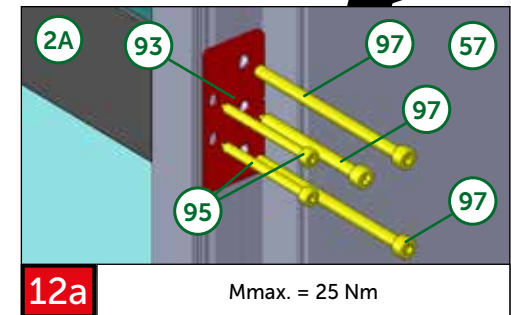
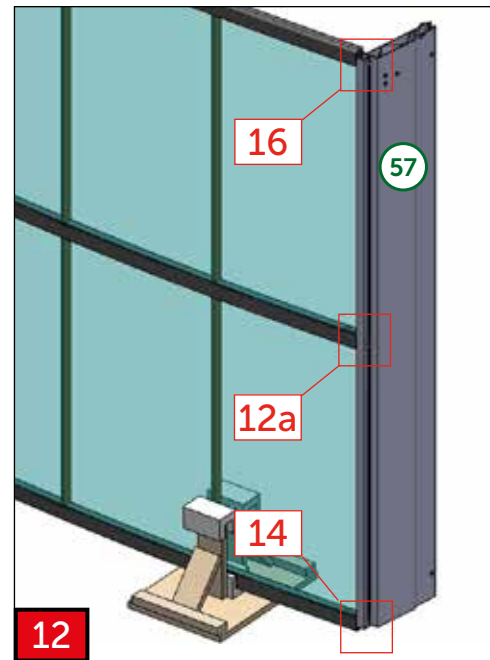
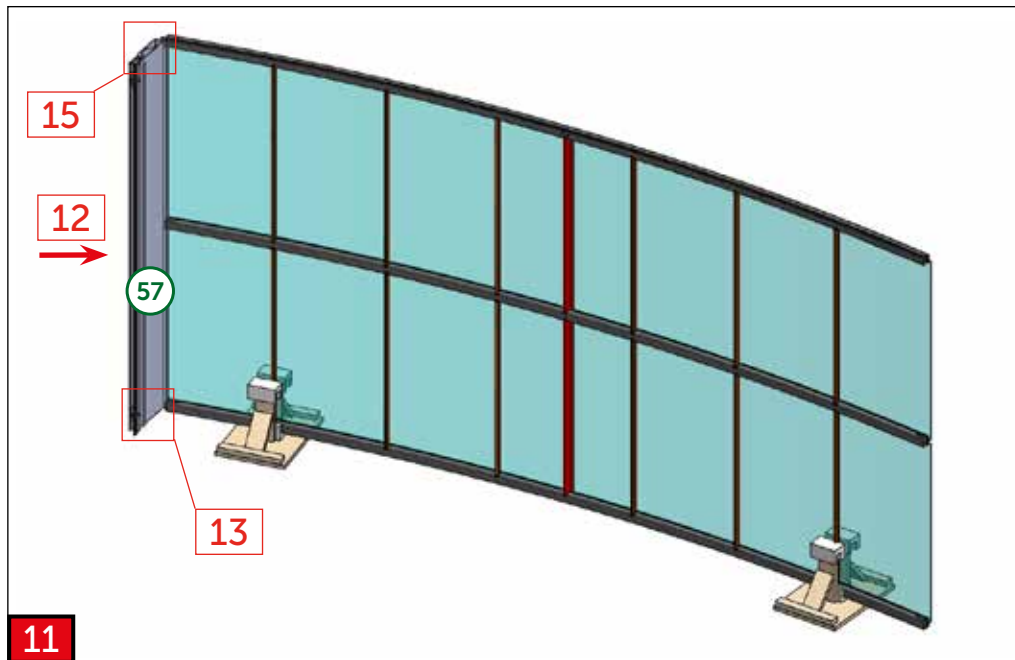

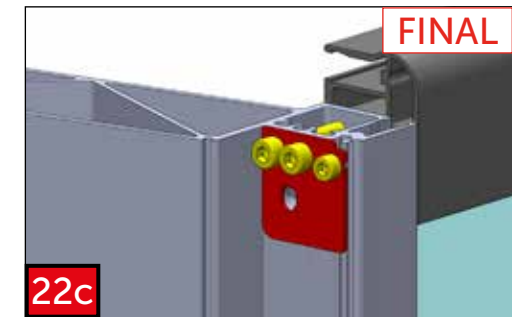
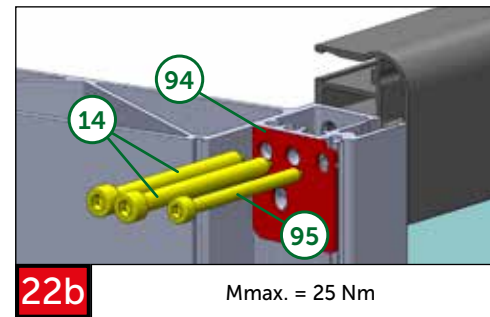
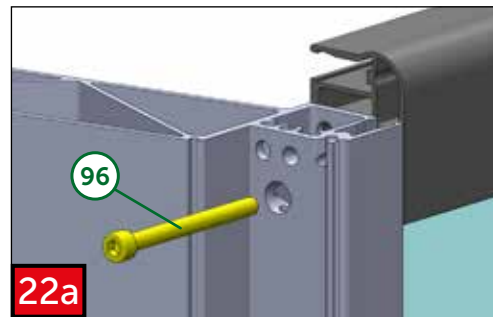
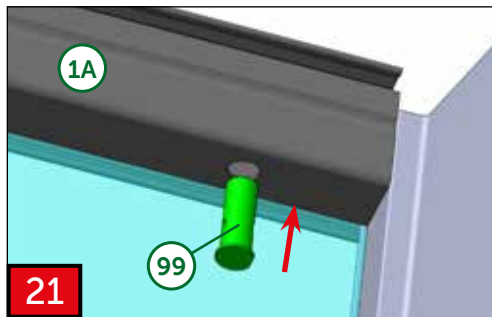
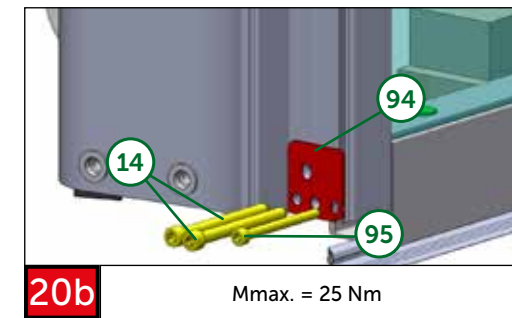
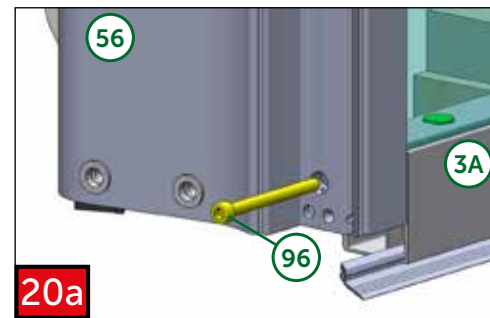
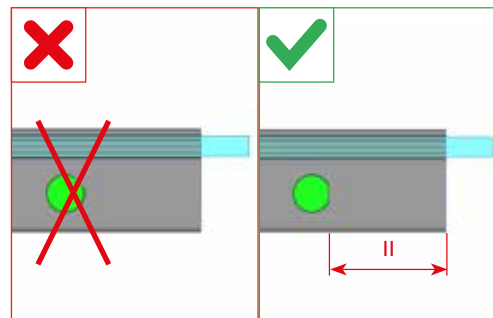
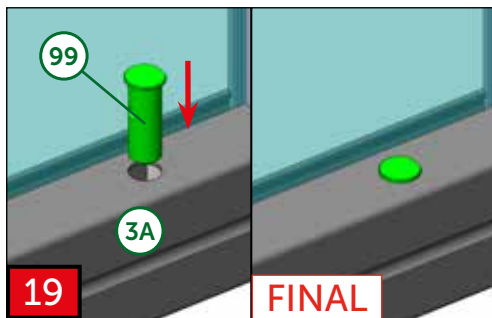
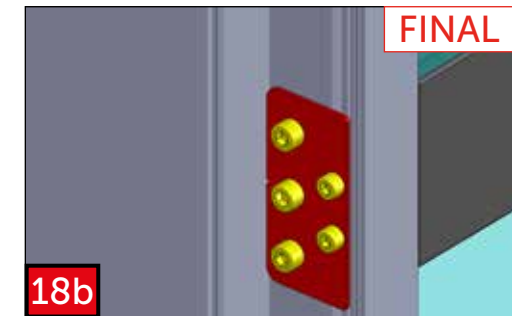
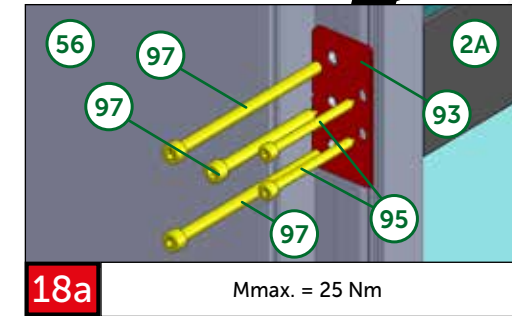
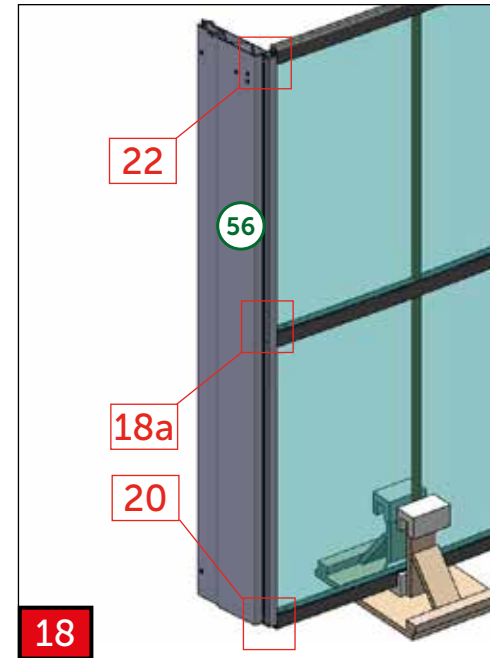
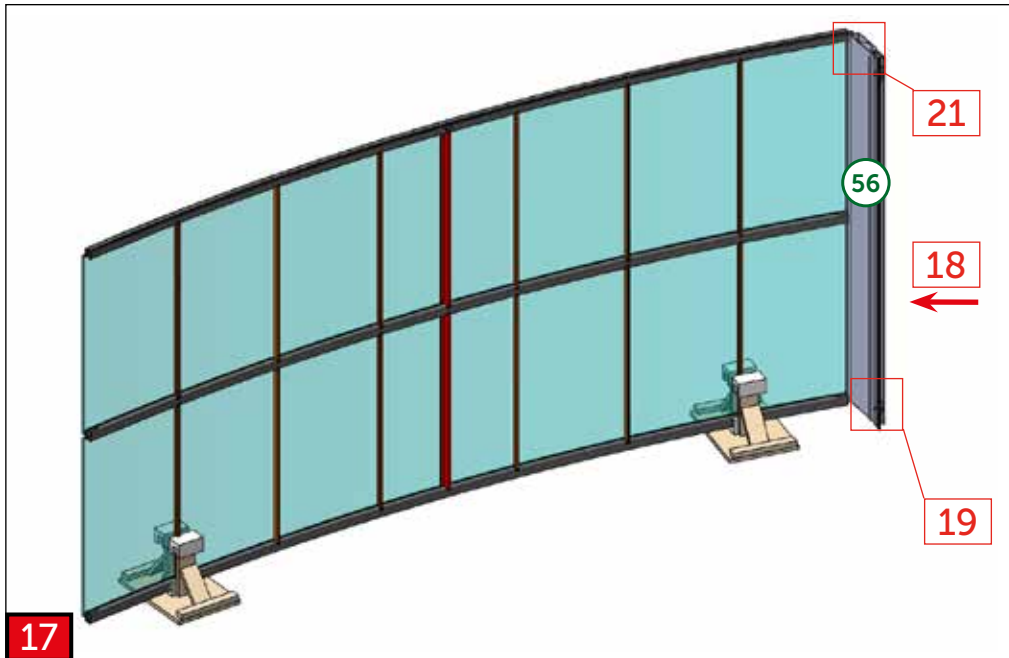

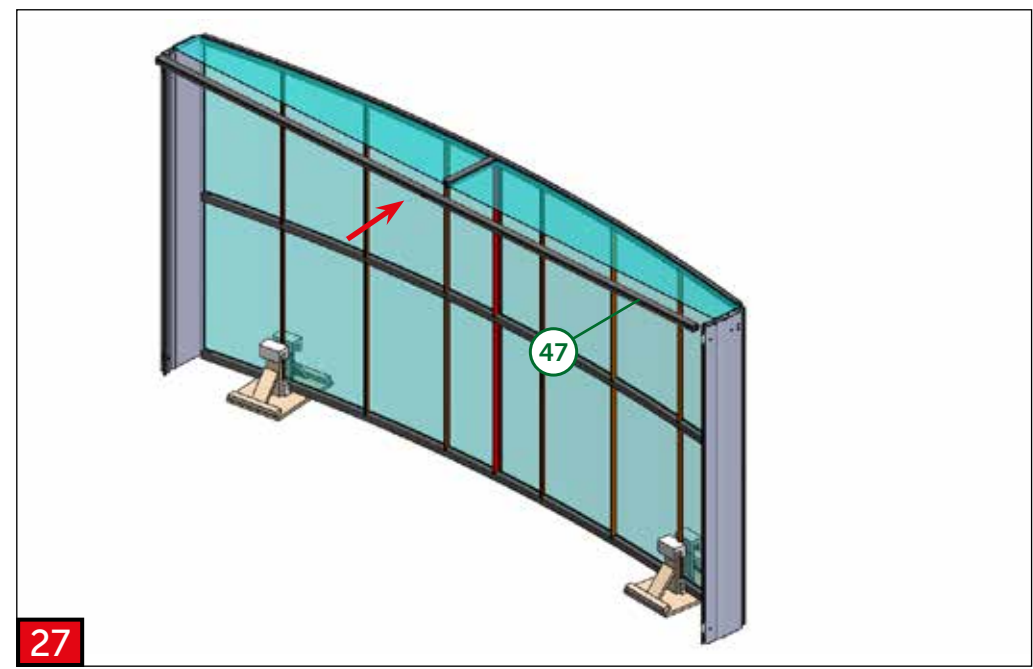
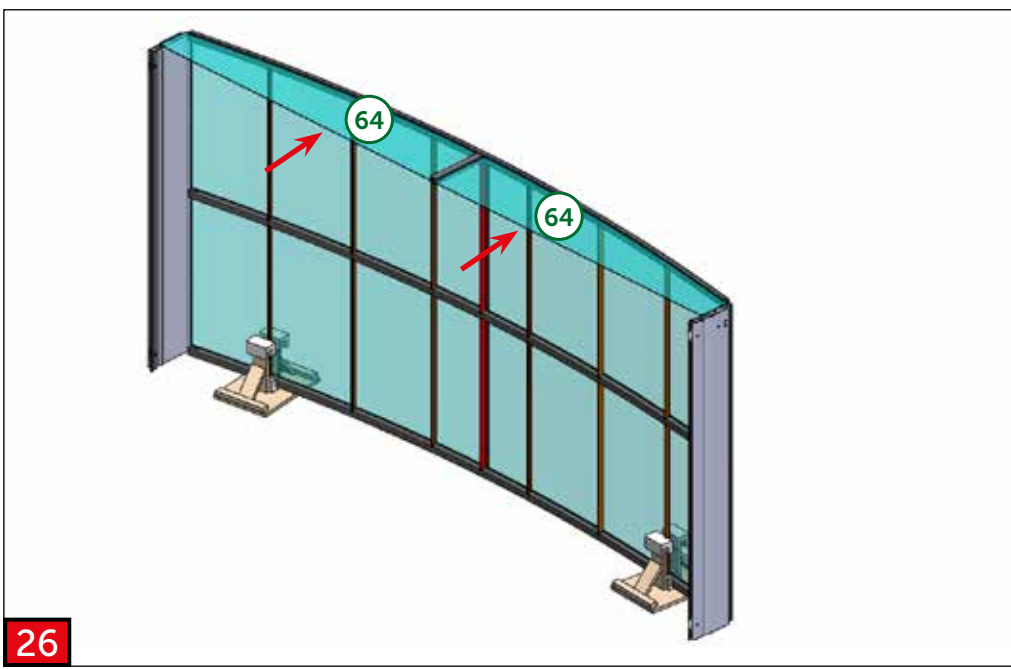
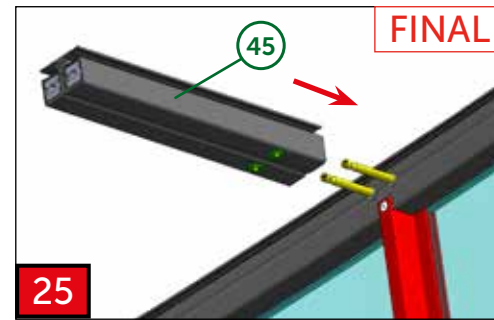
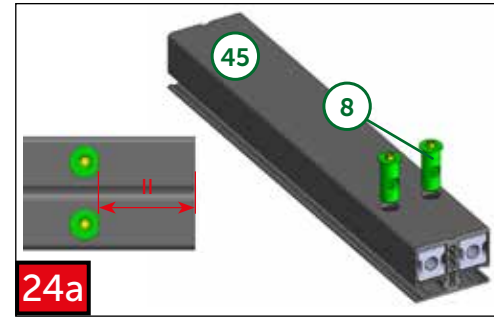
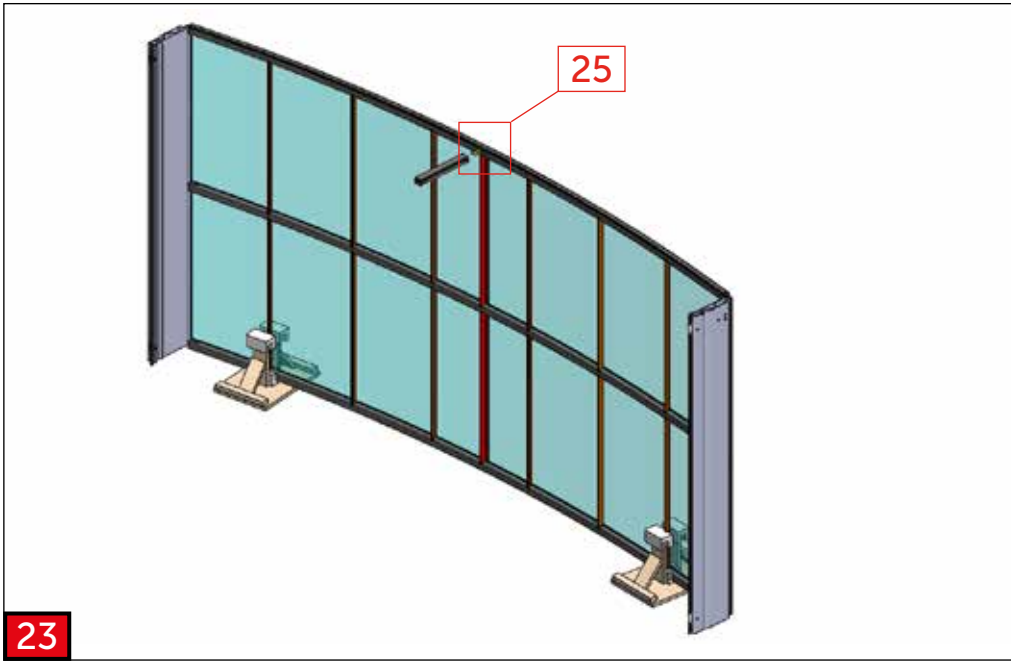

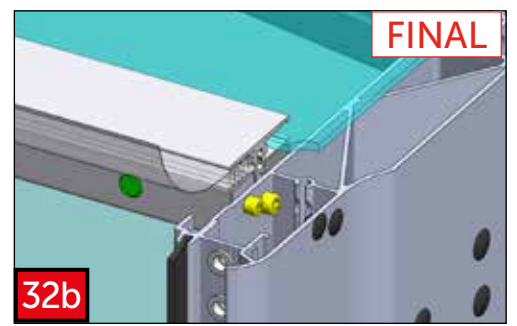
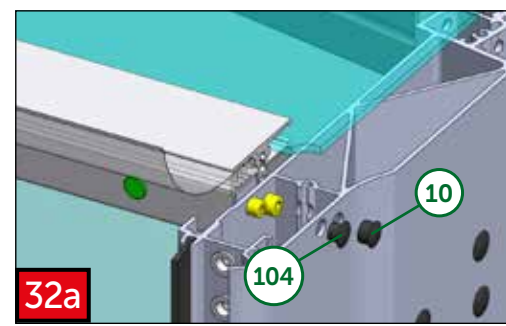
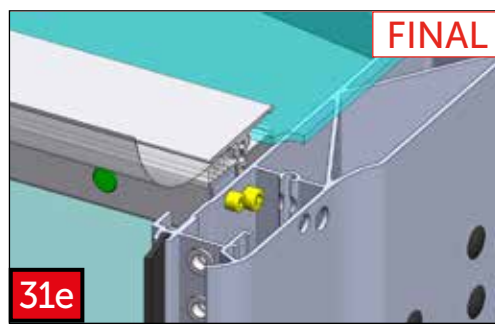
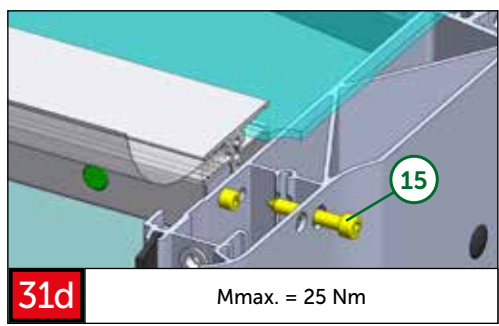
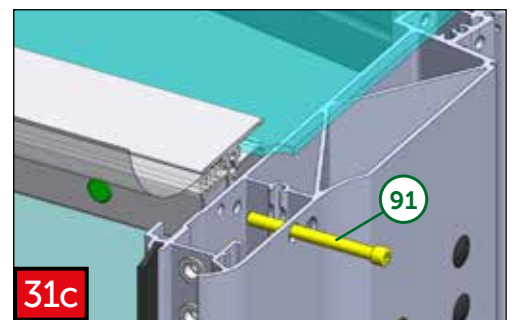
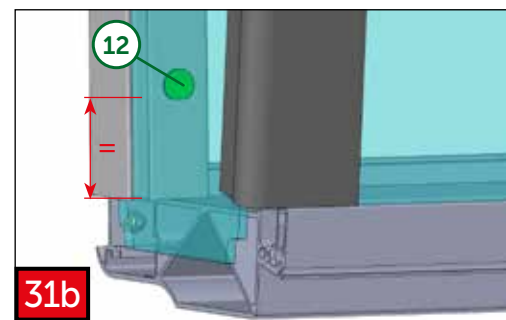
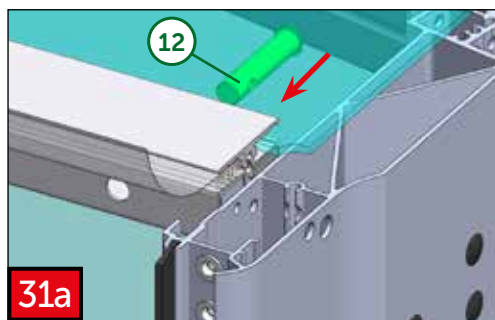
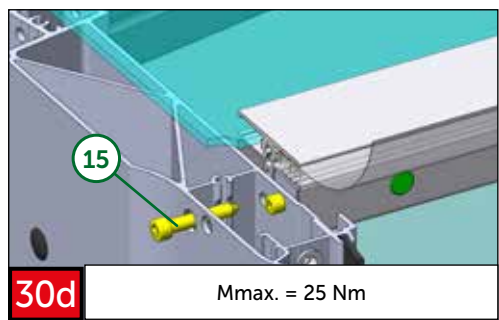
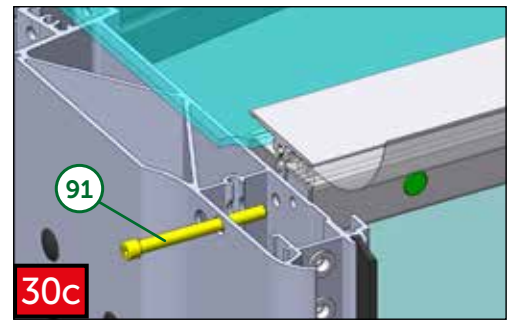
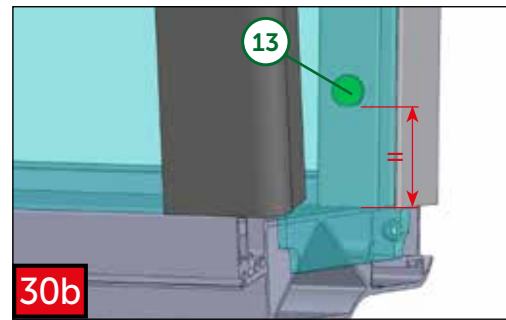
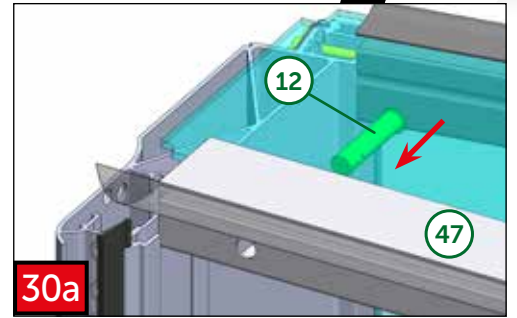
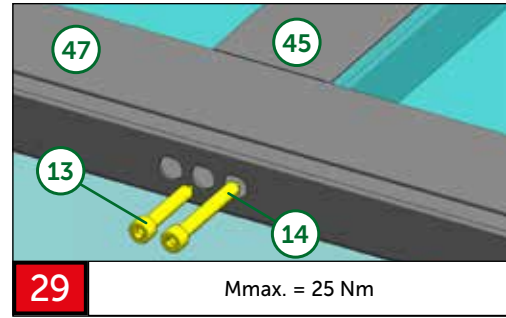
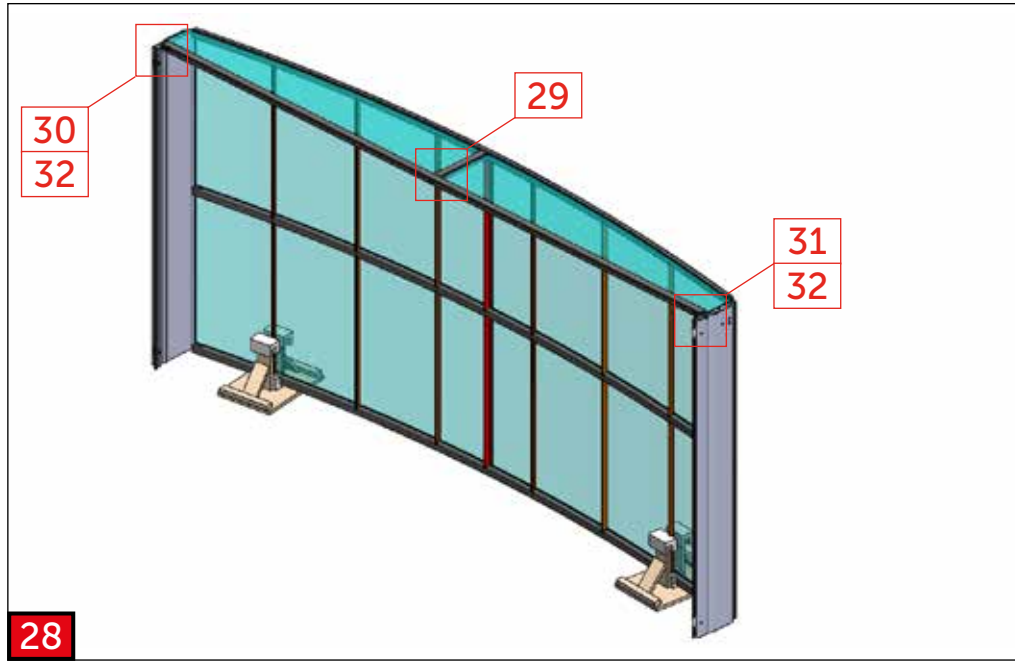

⚠ only SYDNEY CLEAR ⚠

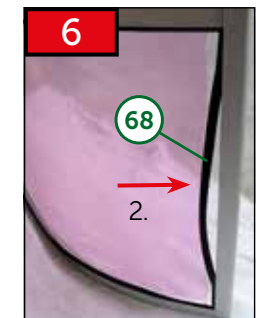
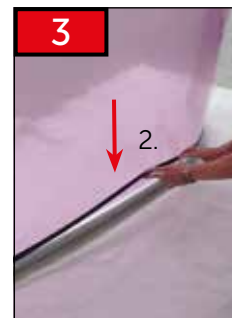
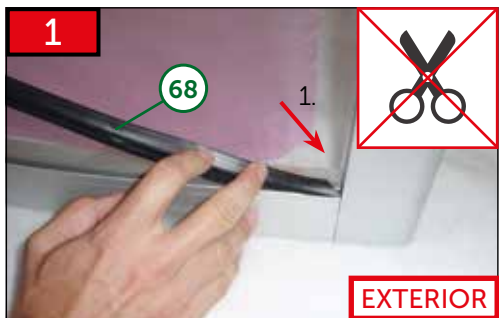
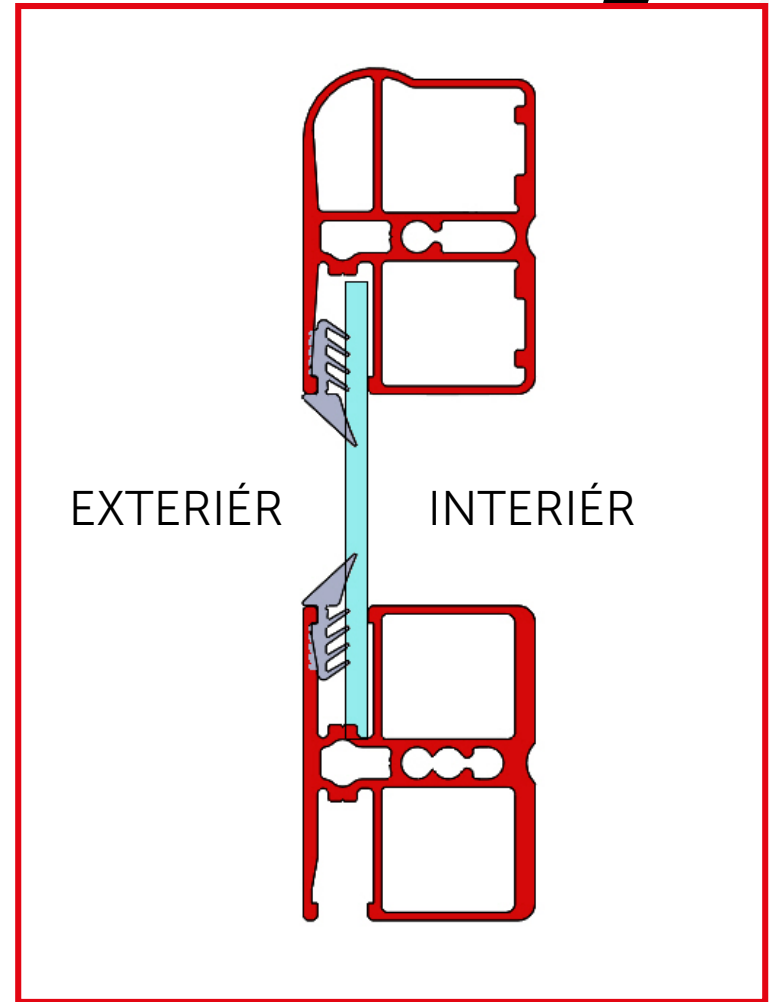
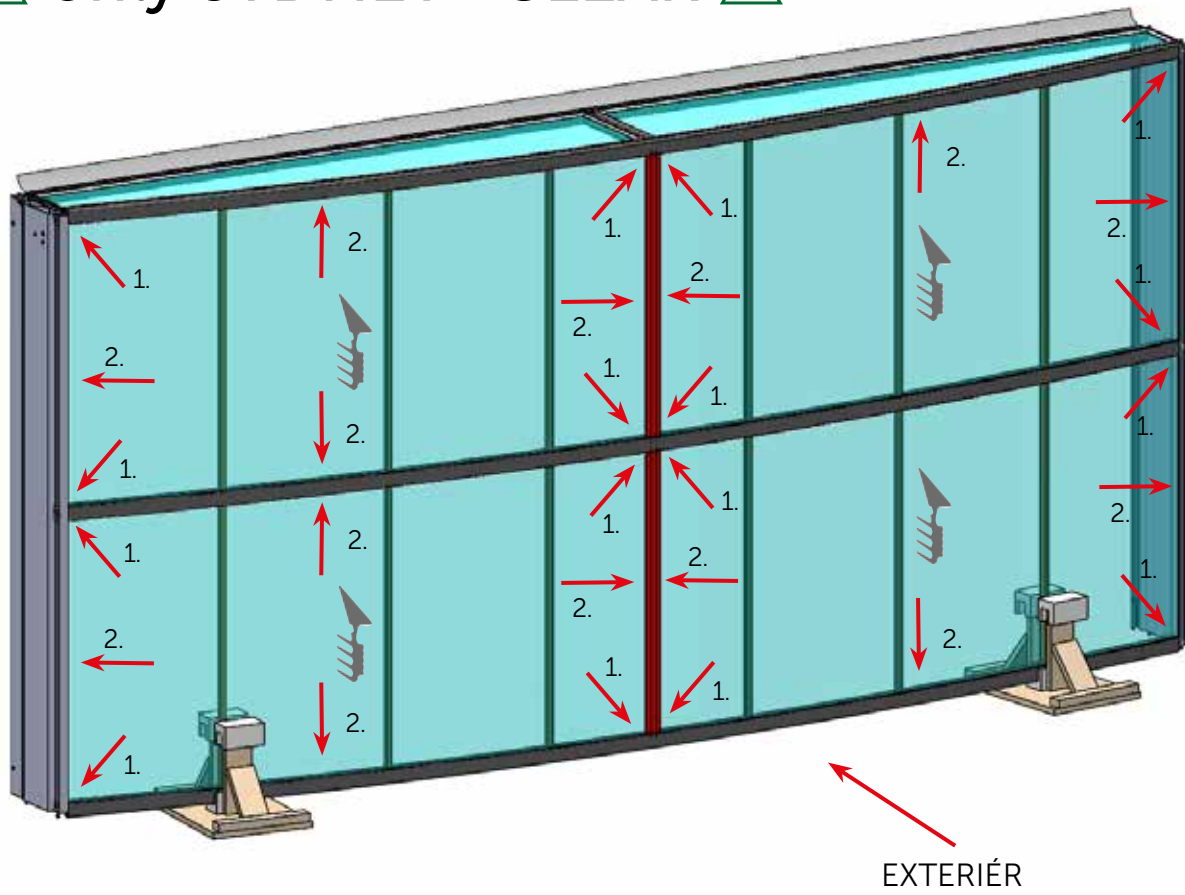

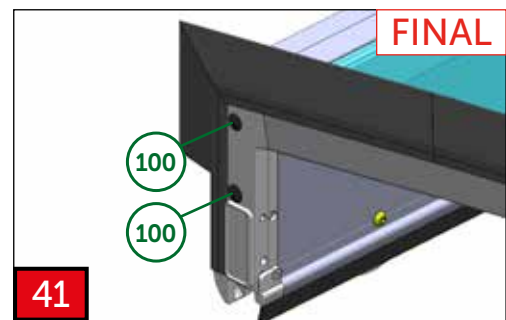
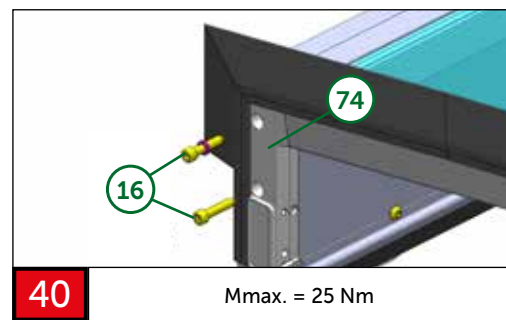
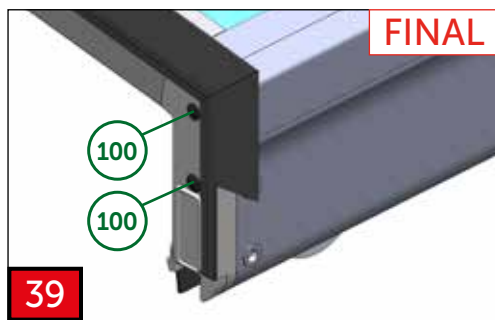
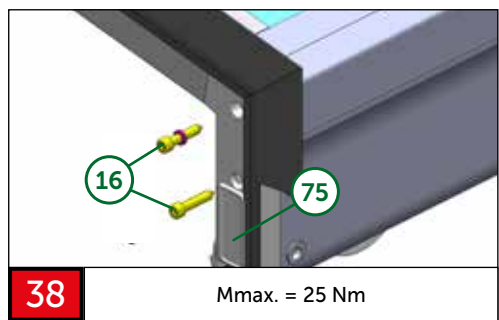
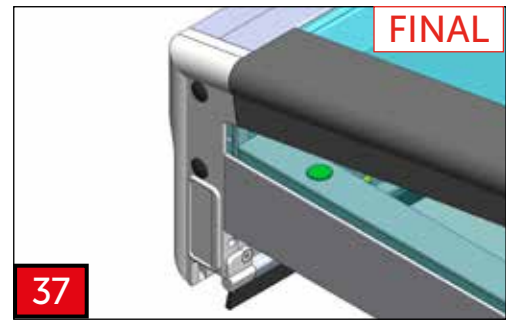
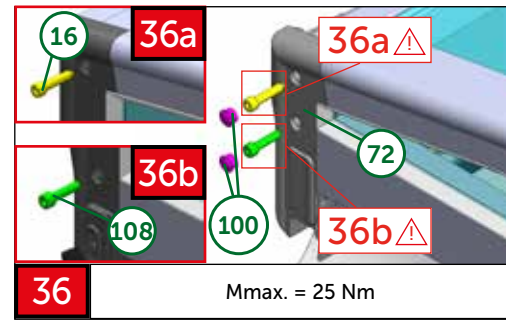
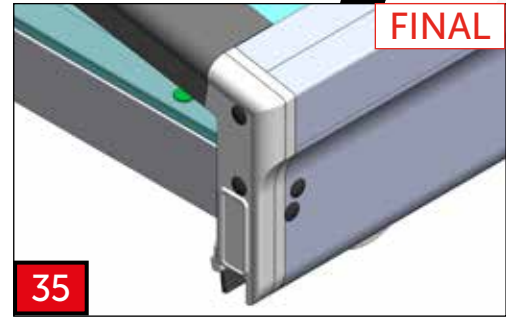
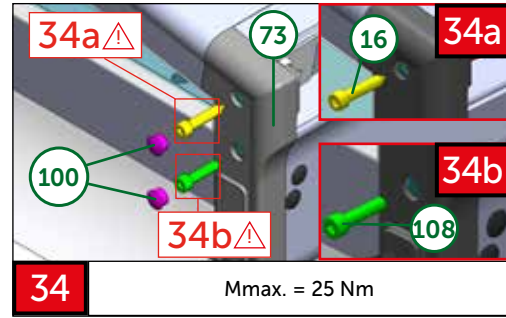
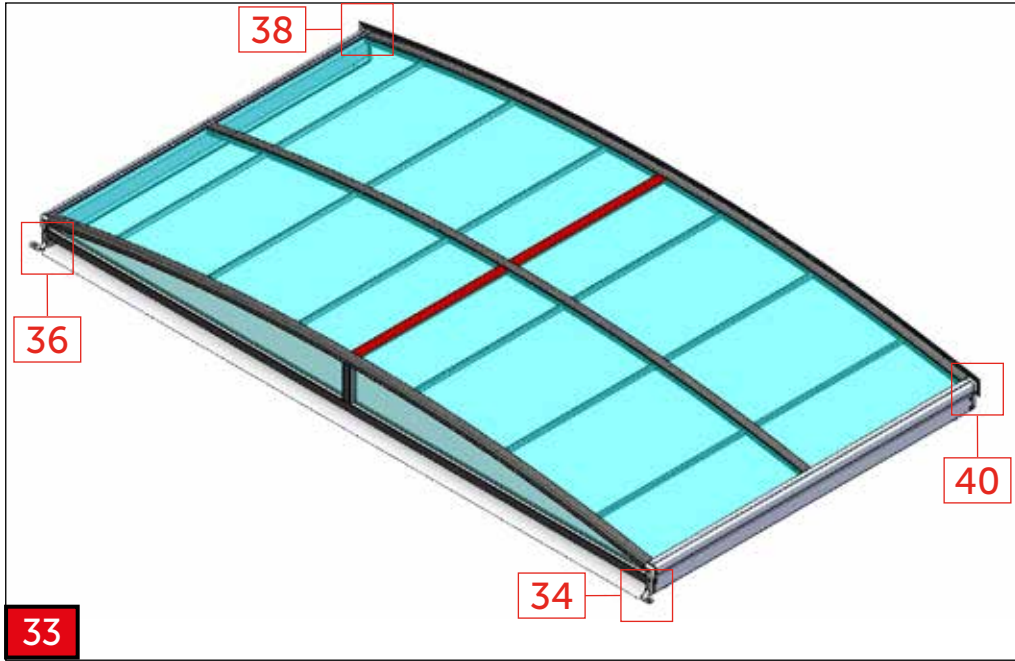

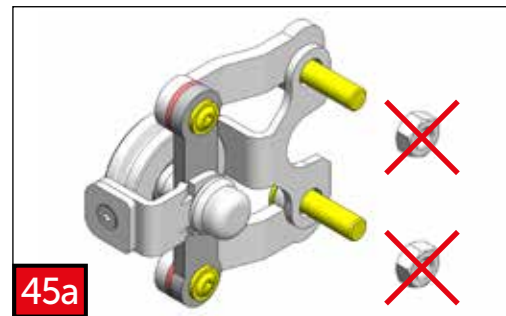
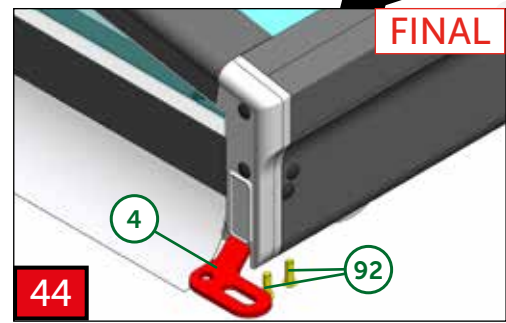
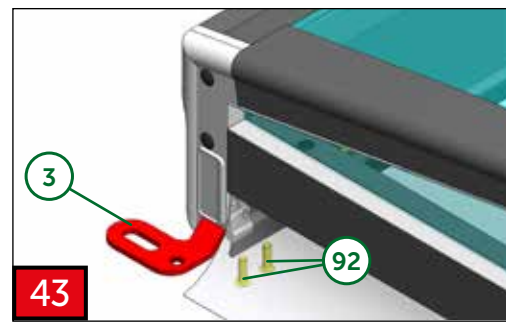
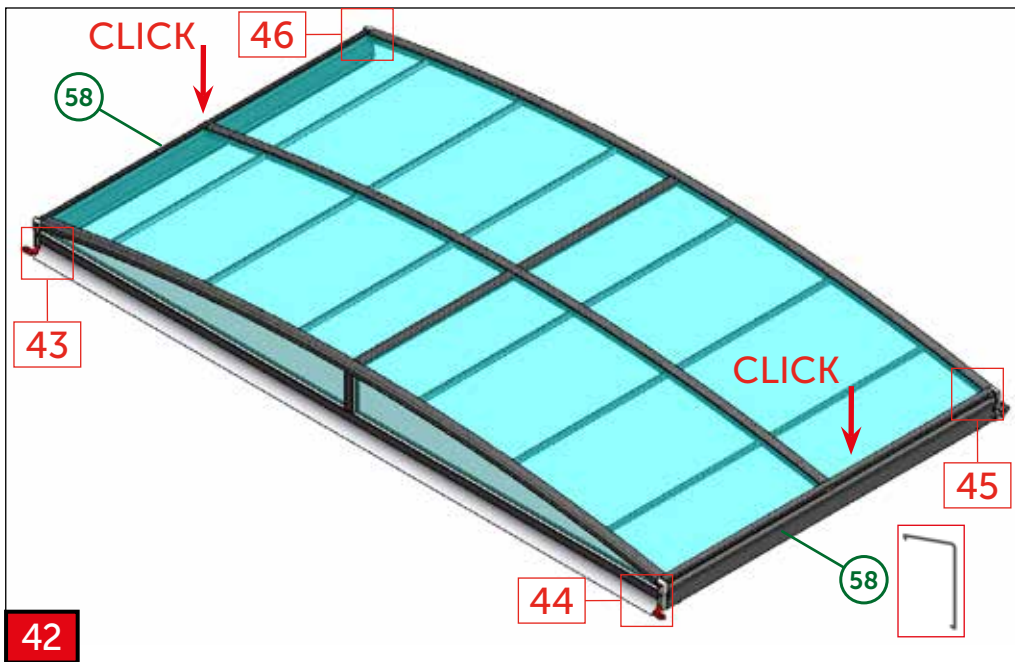

Jistící matky před montáží odstranit
 Remove the lock nuts before mounting
 Sicherungsmutter vor der Montage entfernen
 Enlevez les contre-écrous avant le montage
 Перед установкой снимите стопорные гайки

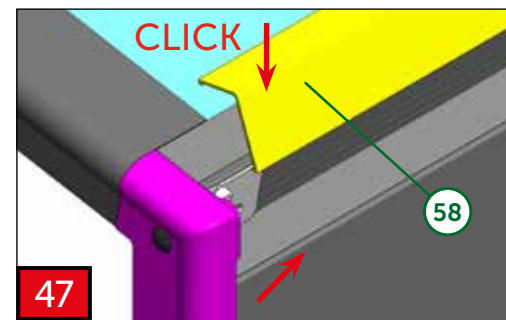
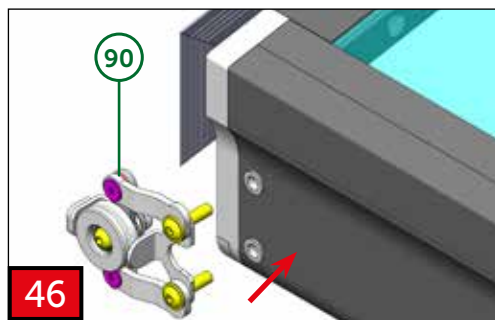
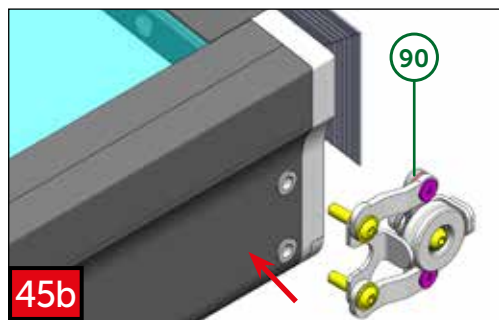

⚠ only SYDNEY CLEAR ⚠

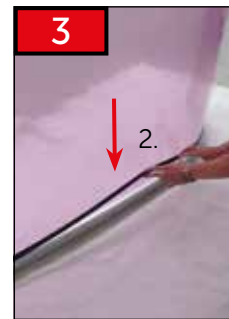
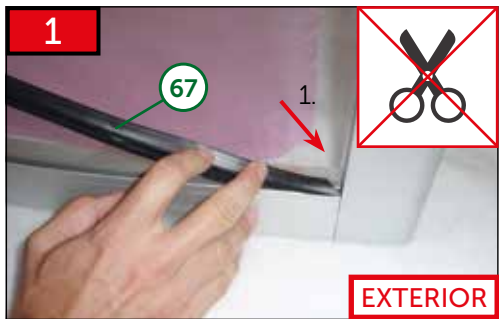
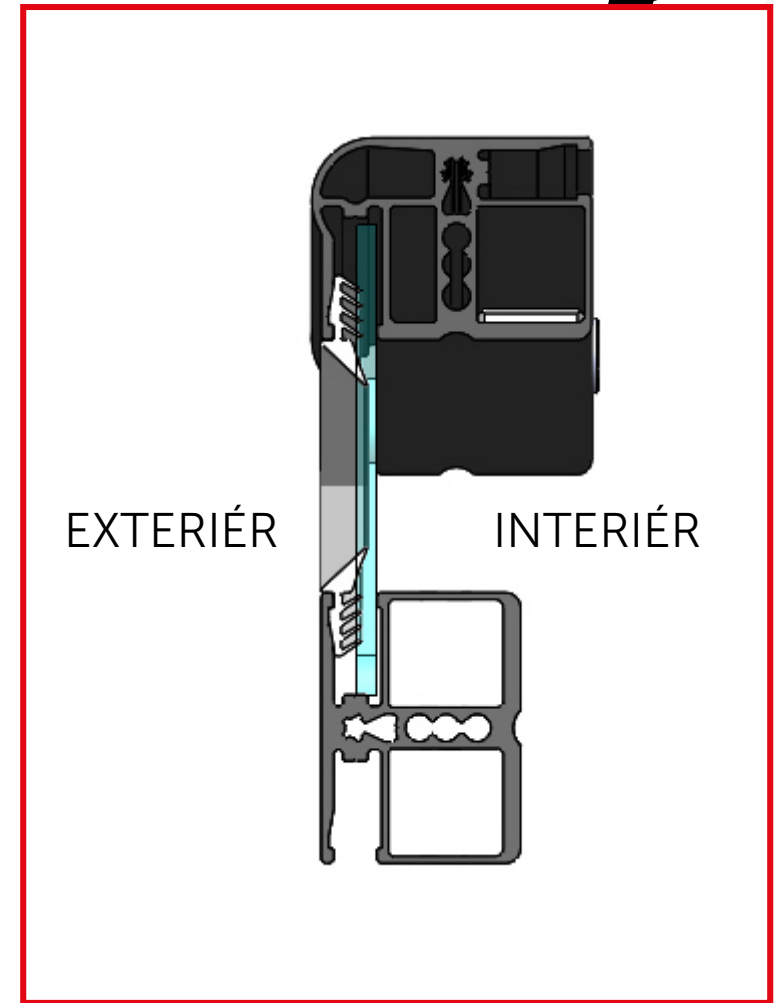
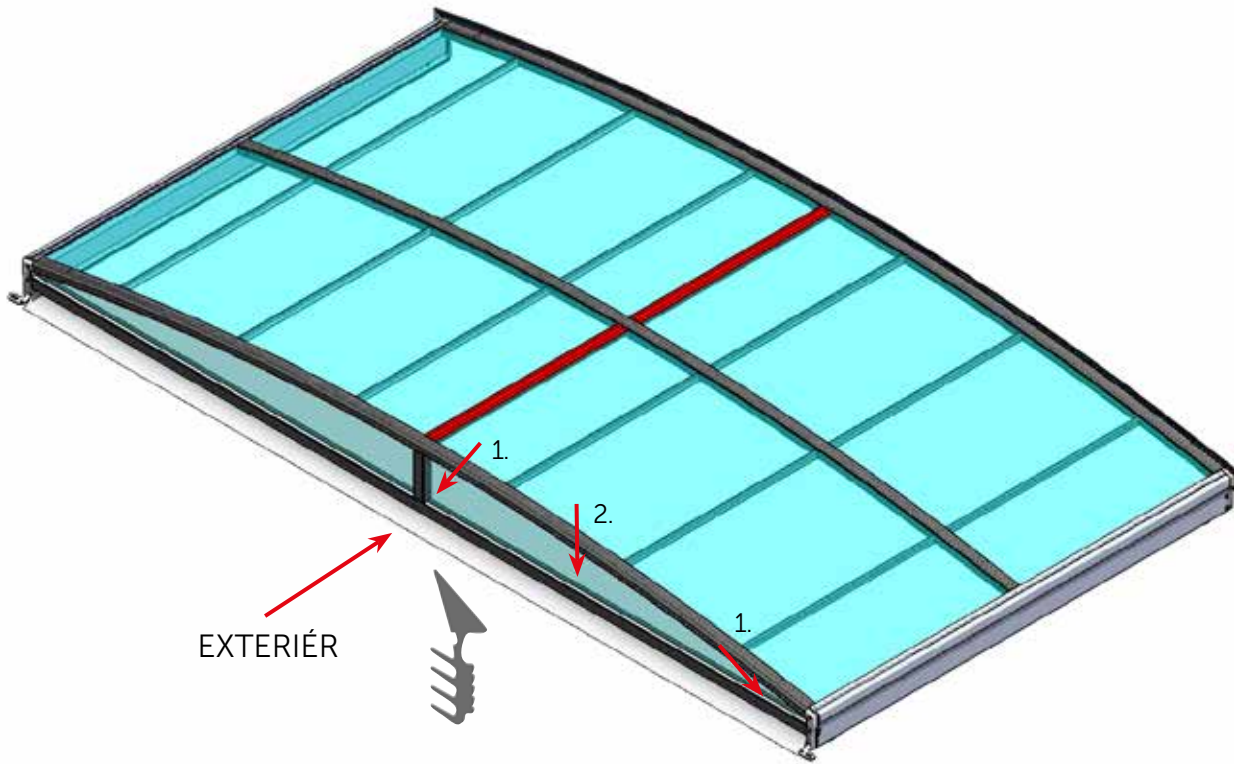

Umístění modulů na bazén
Placing of modules on the swimming pool
Lage der Module auf dem Pool
Emplacement des modules au-dessus de la piscine
Расположение модулей на бассейне

OPTIONAL "KL"

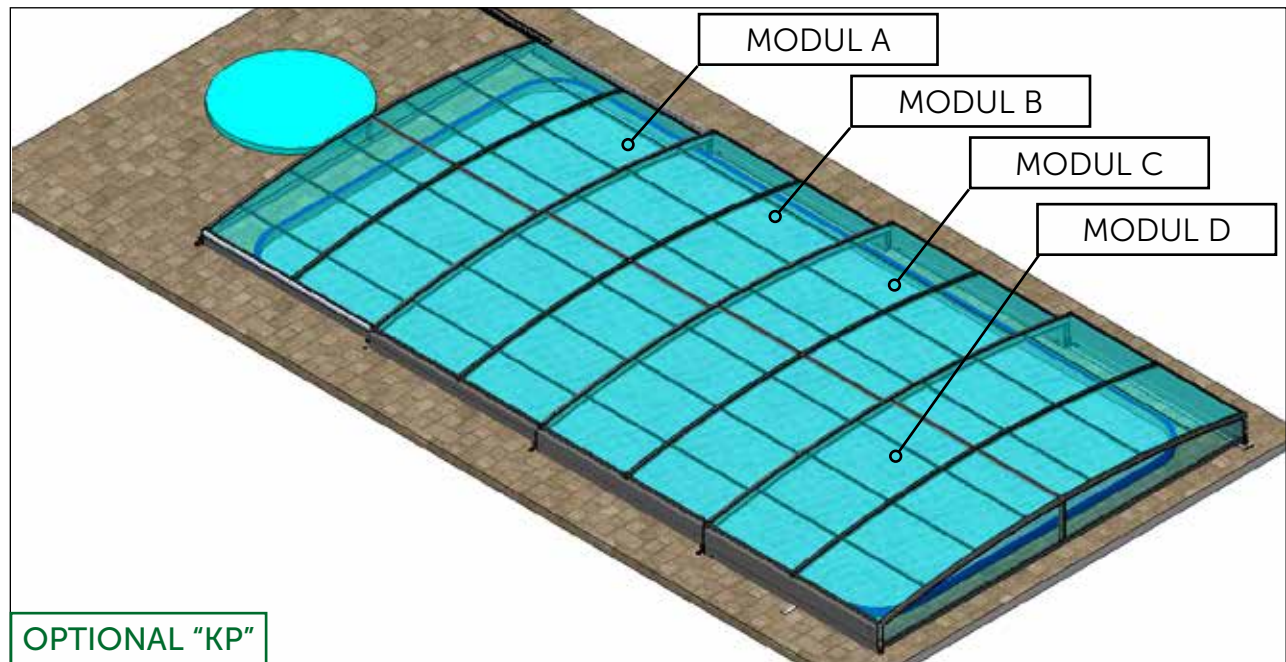
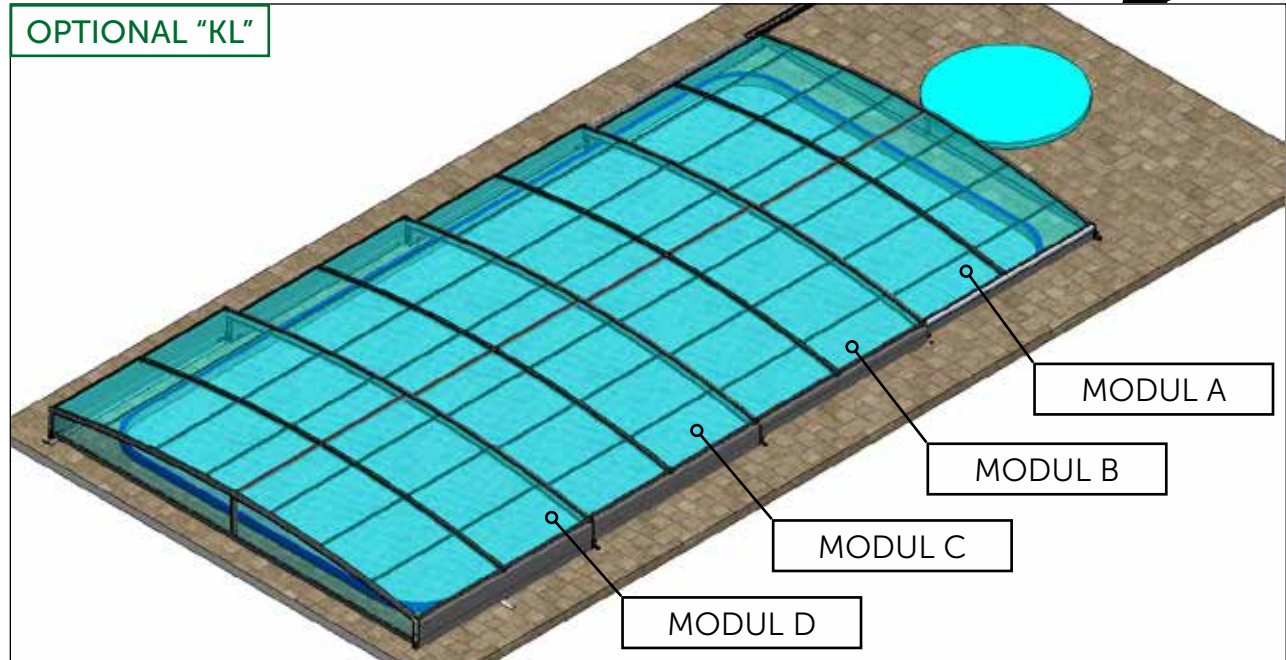

OPTIONAL "KP"

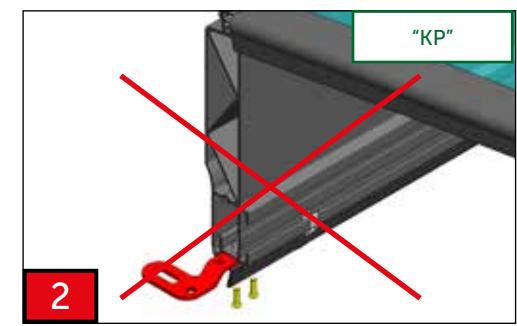
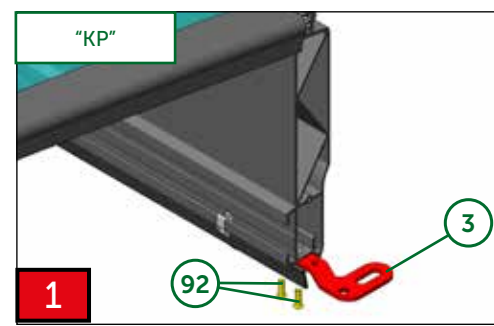
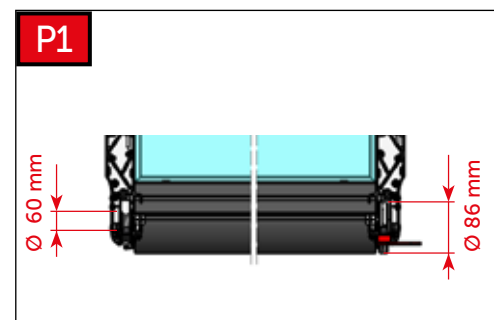
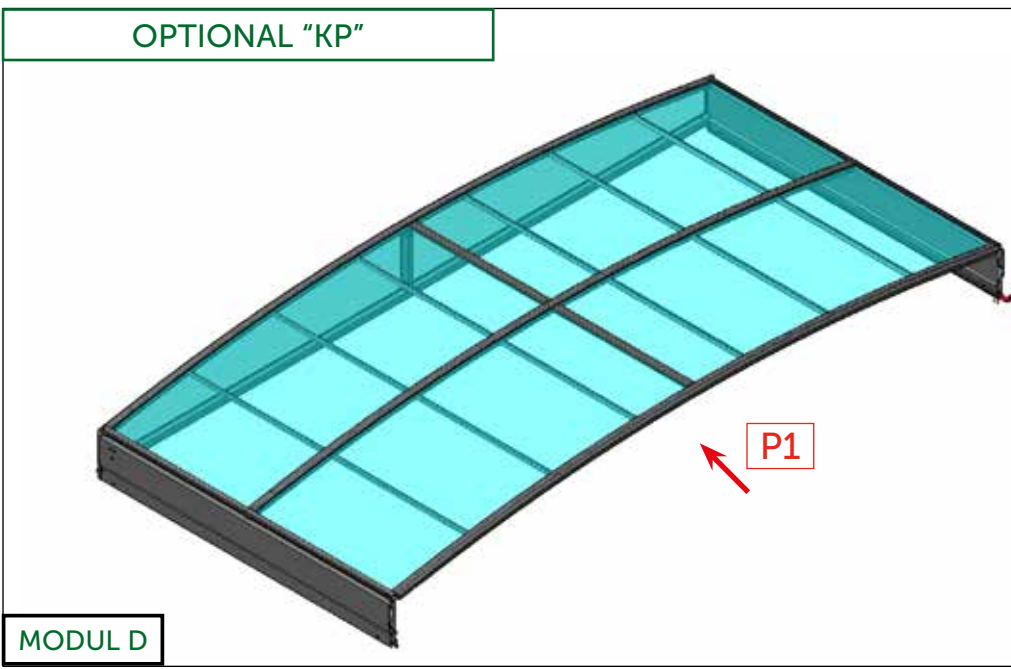
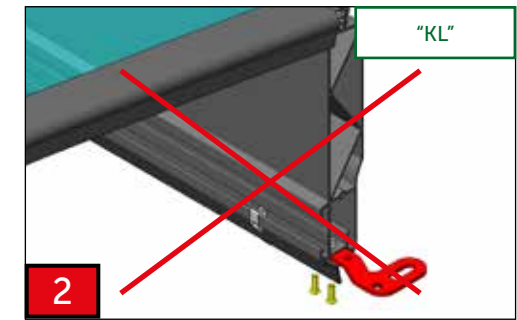
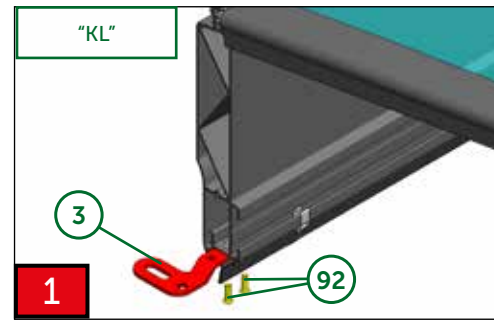
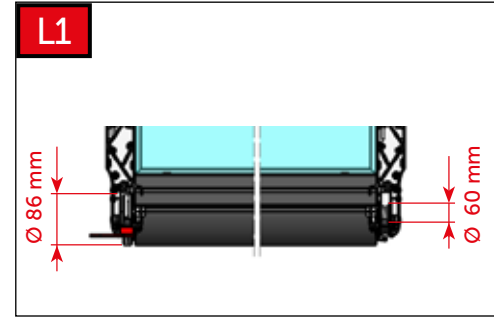
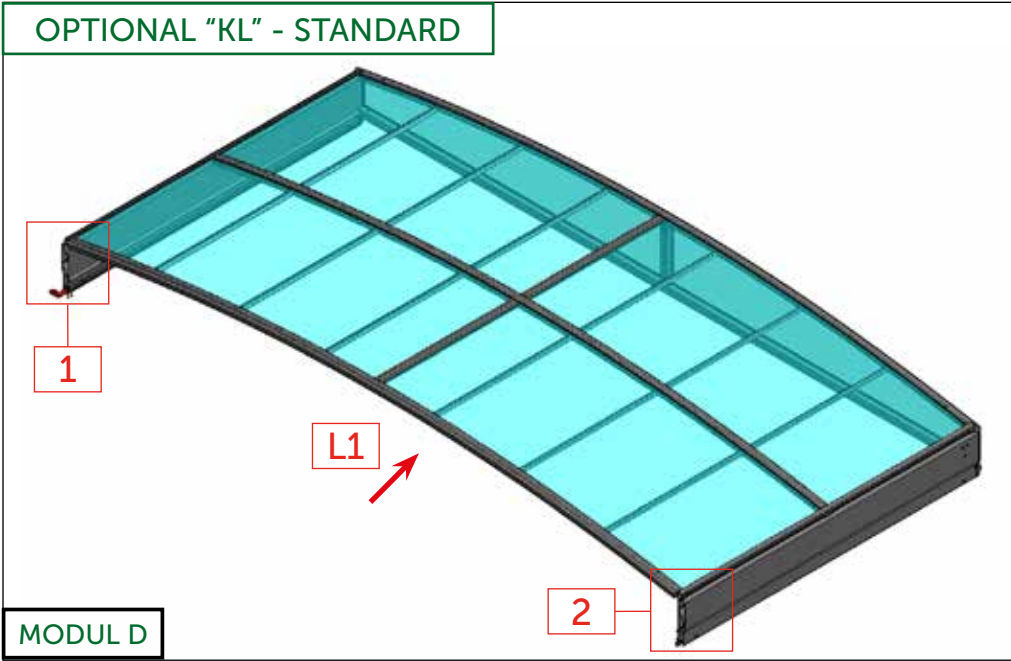

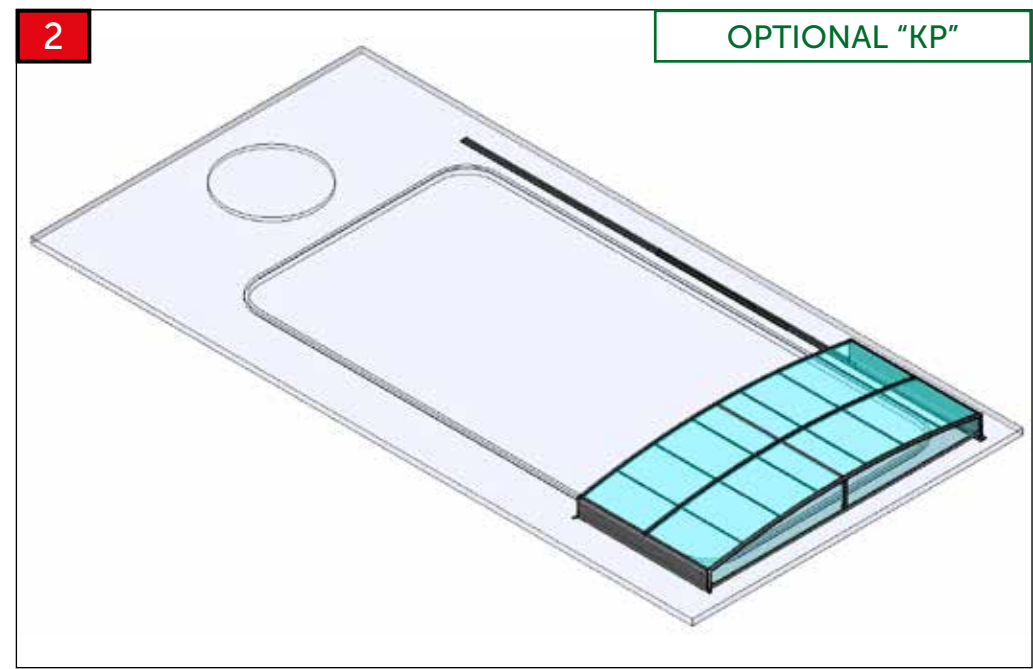
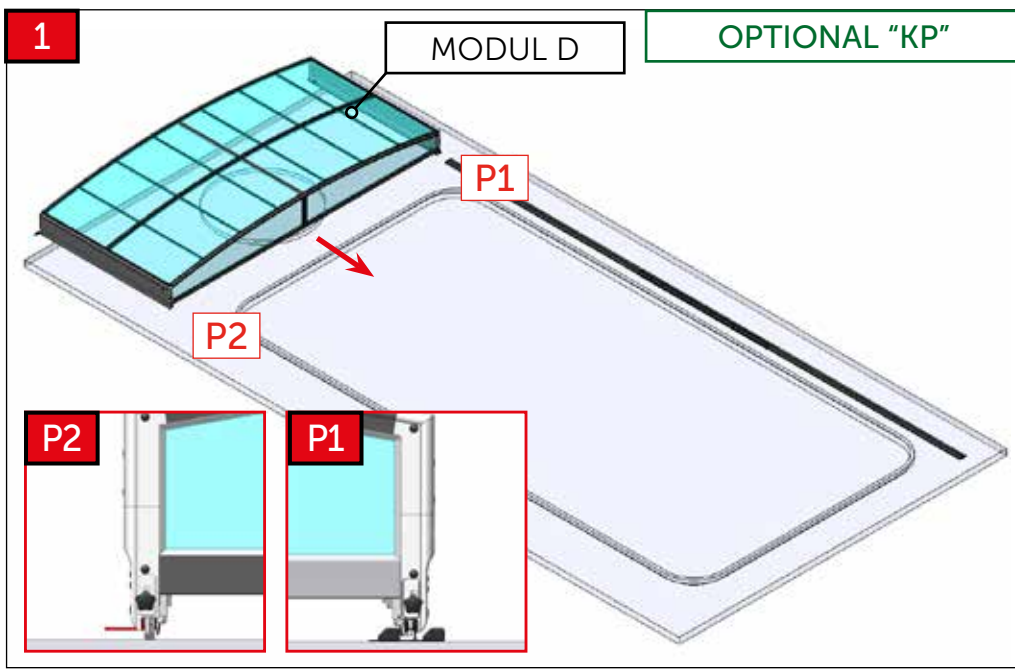
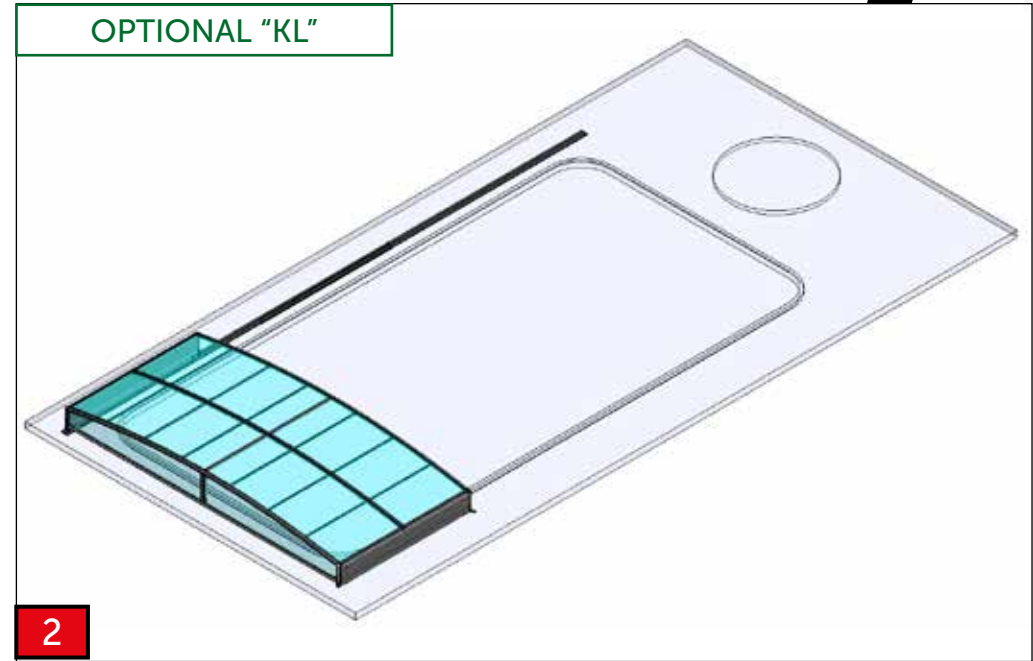
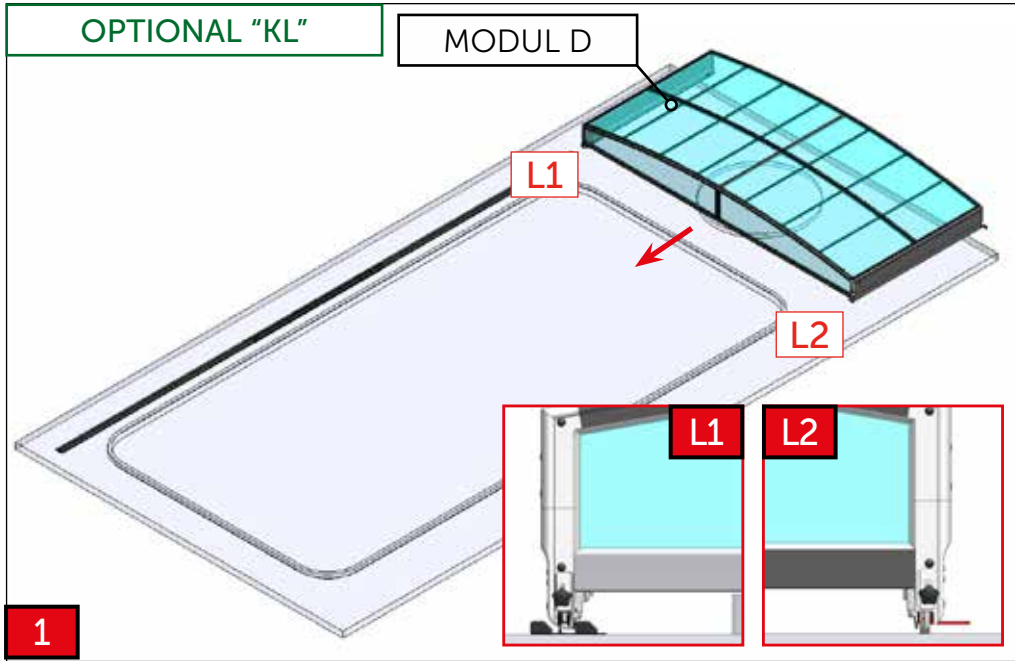

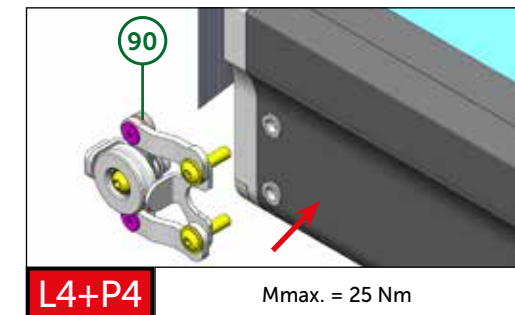
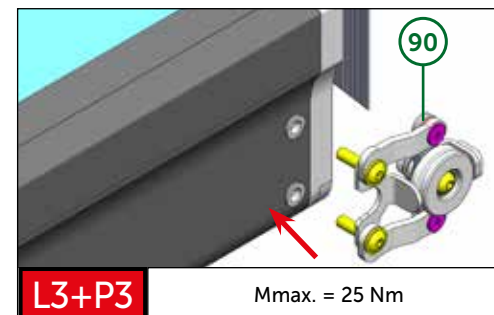
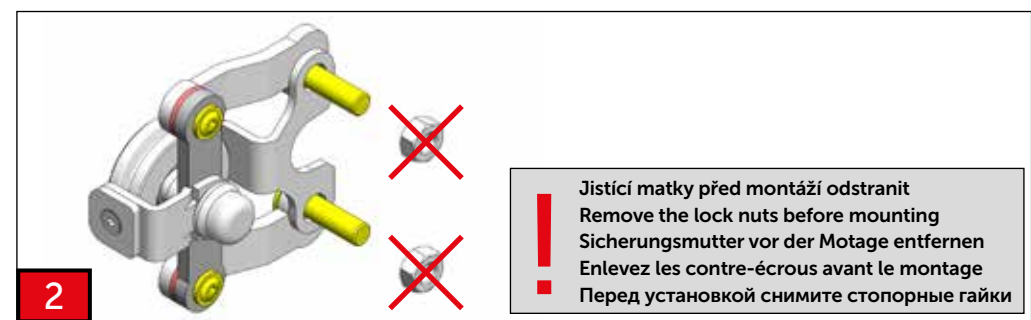
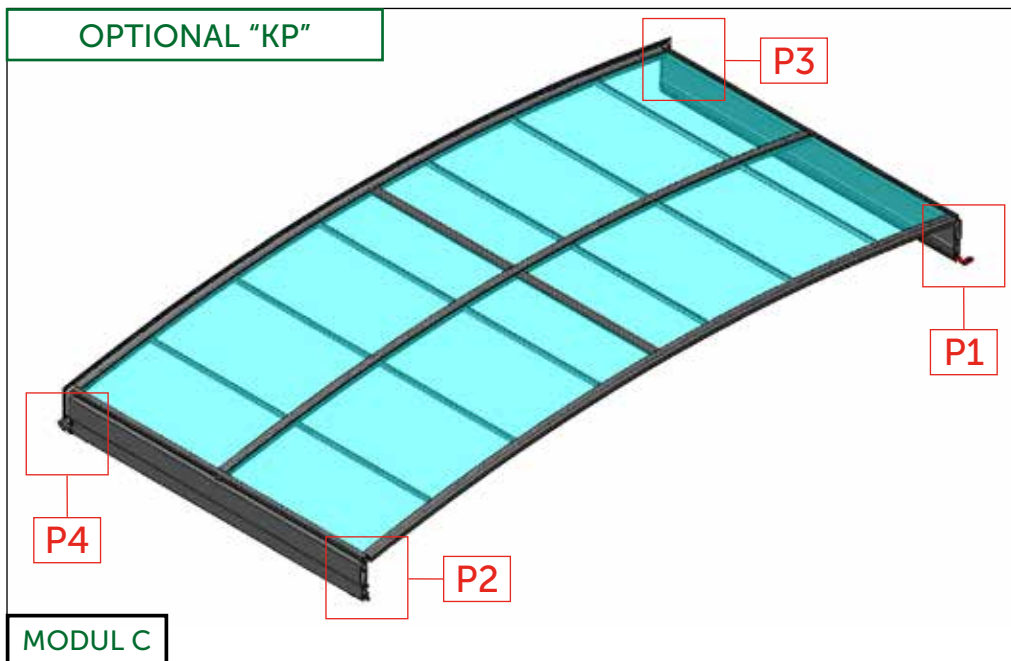
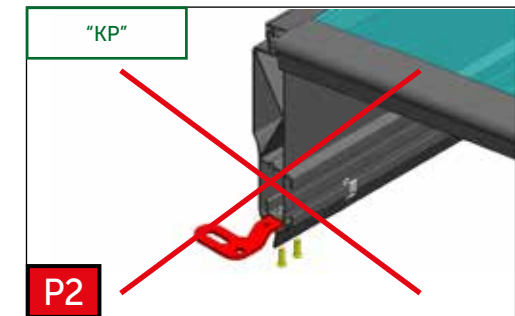
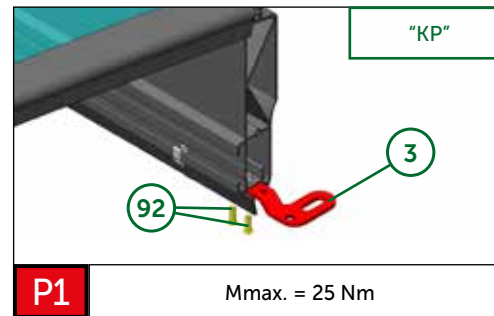
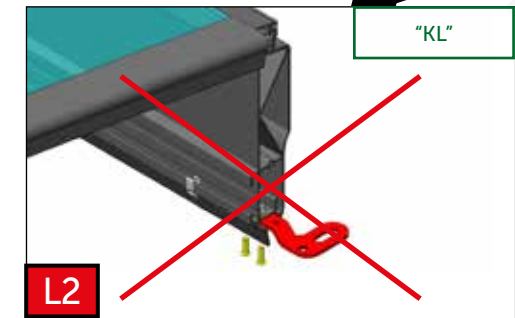
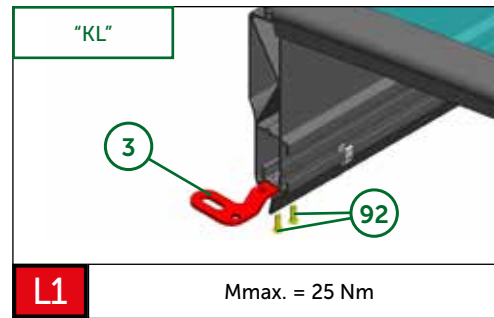
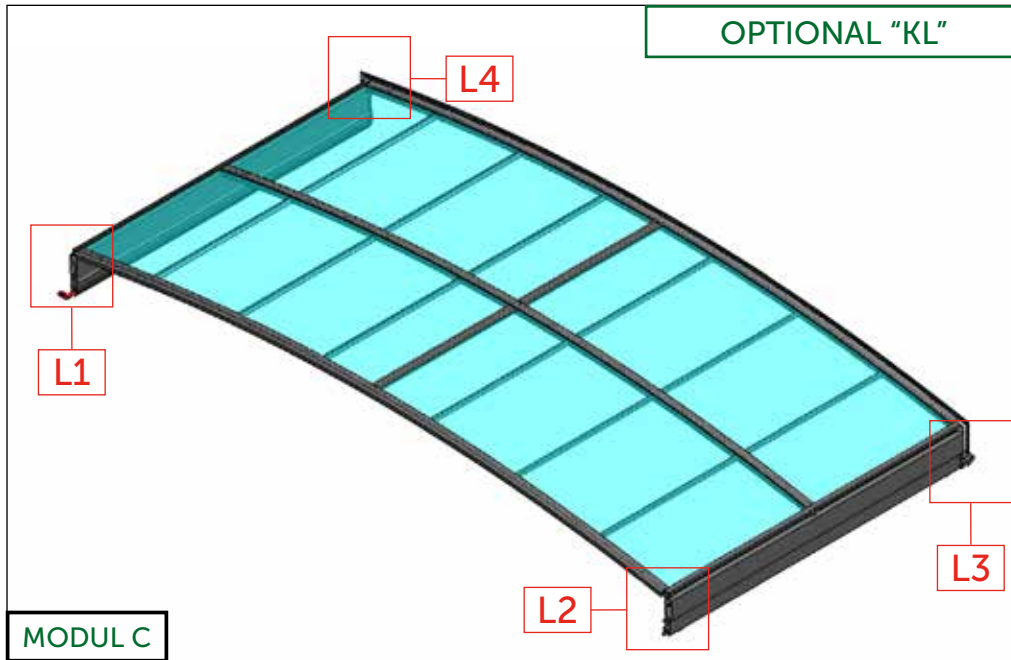

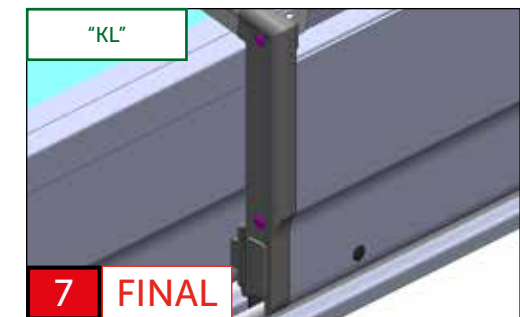
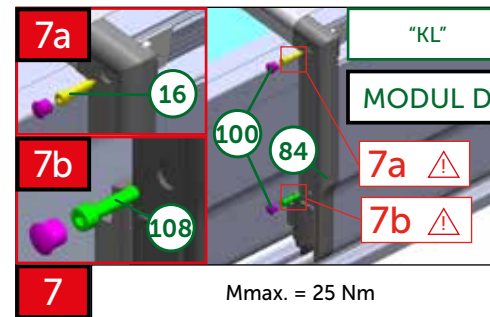
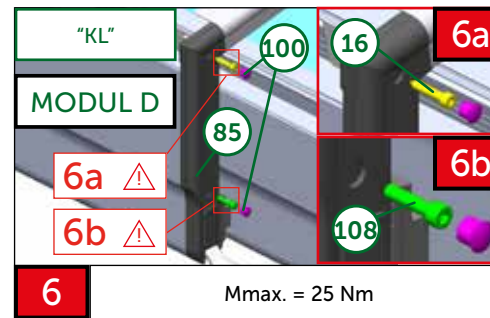
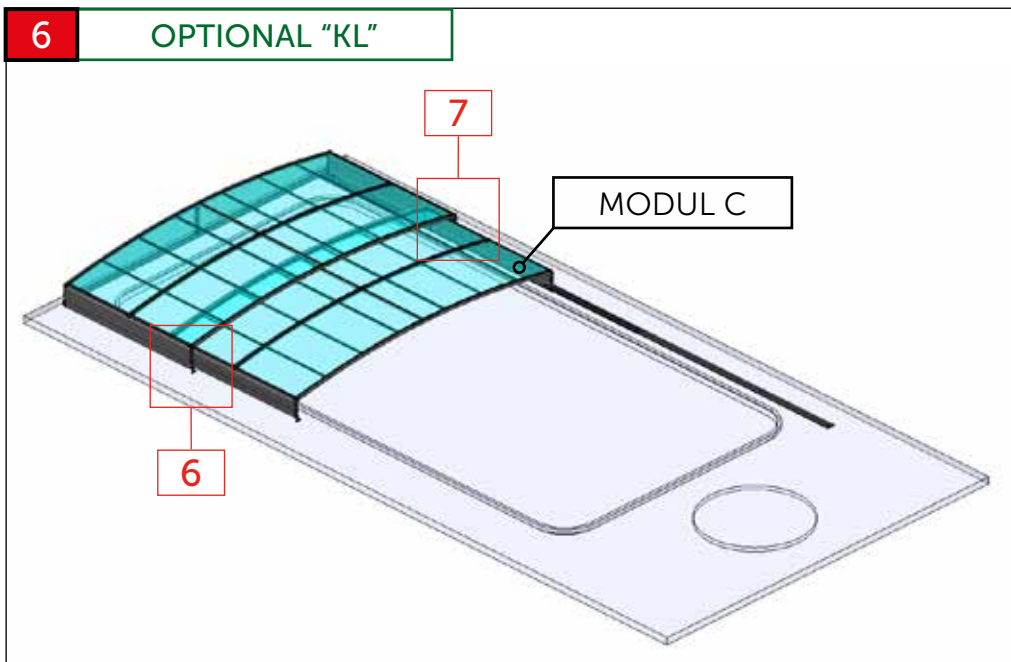
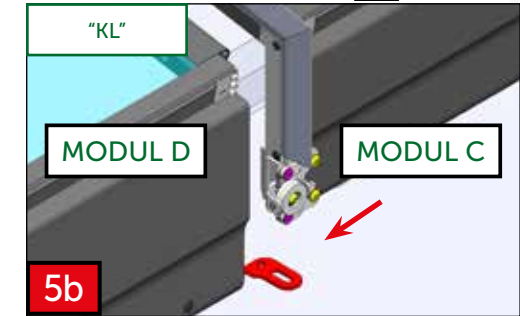
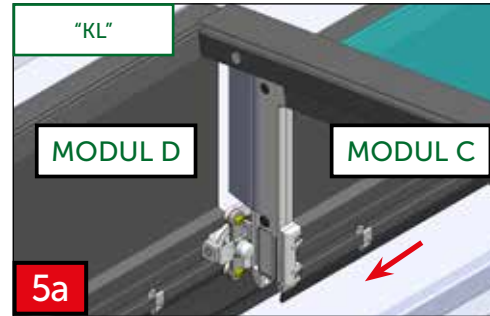
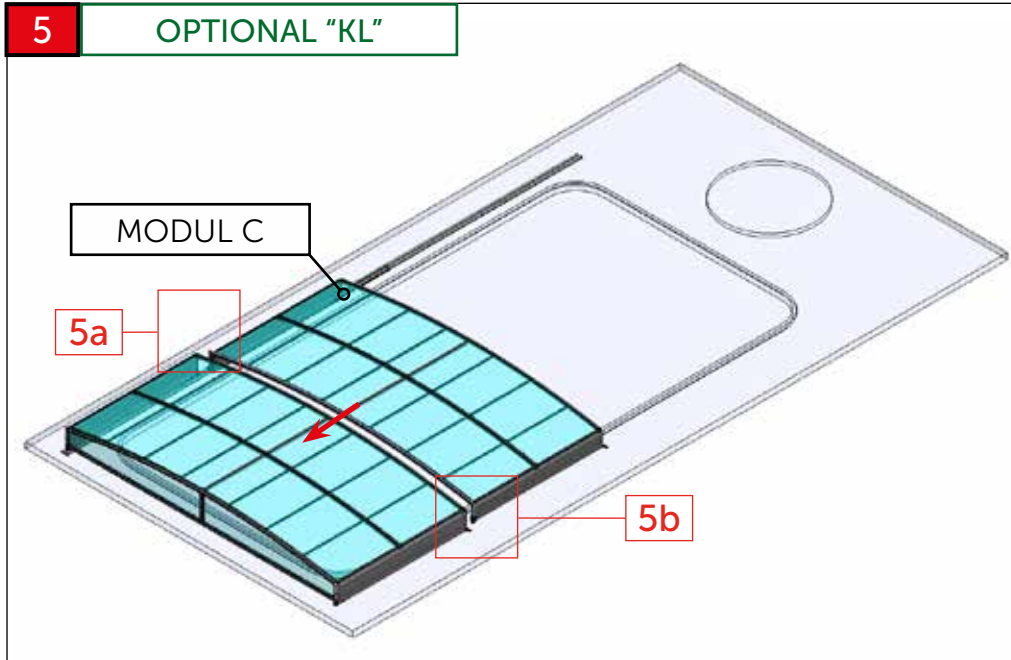

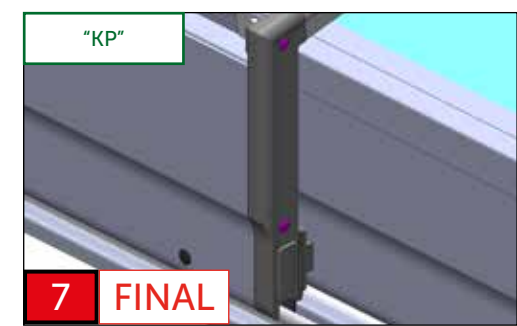
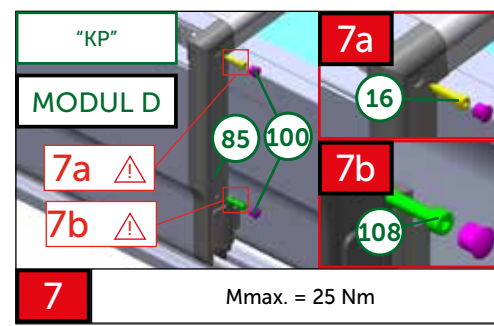
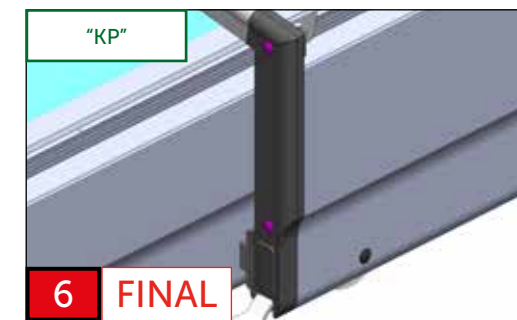
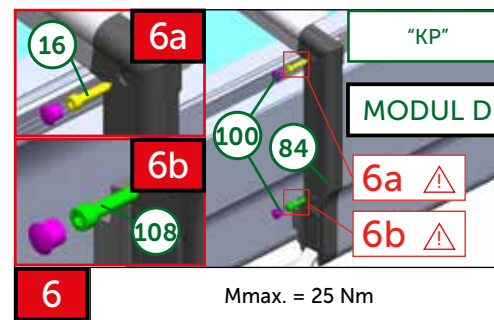
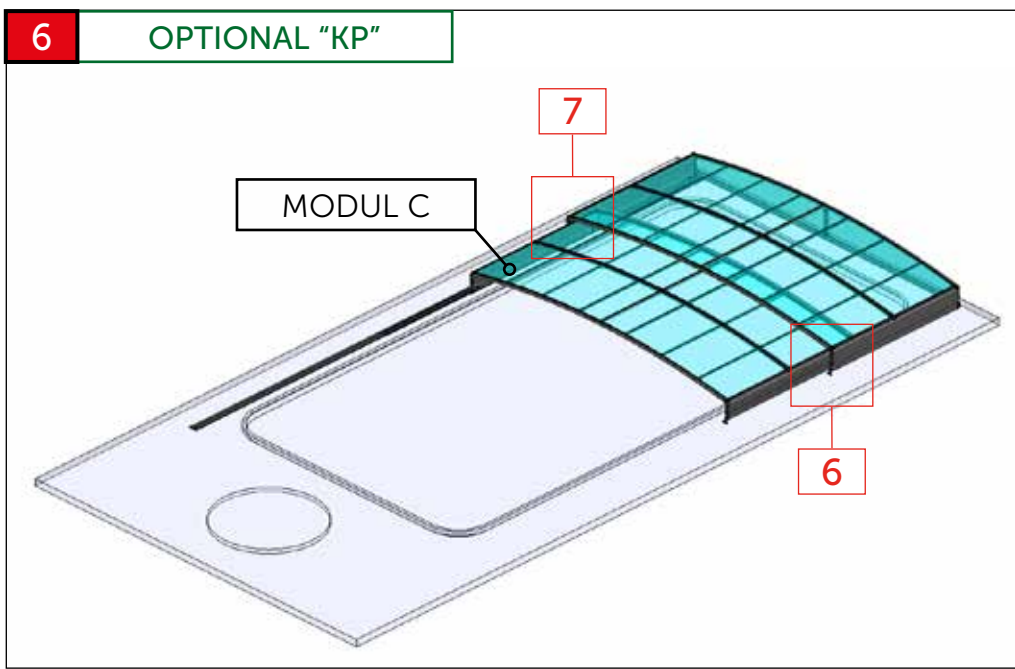
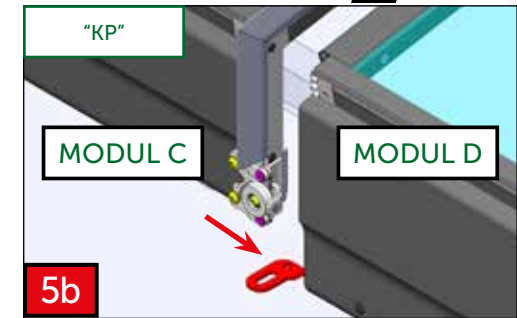
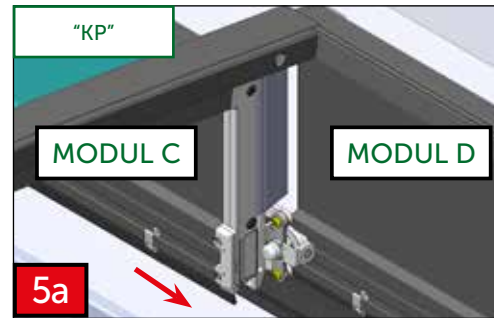
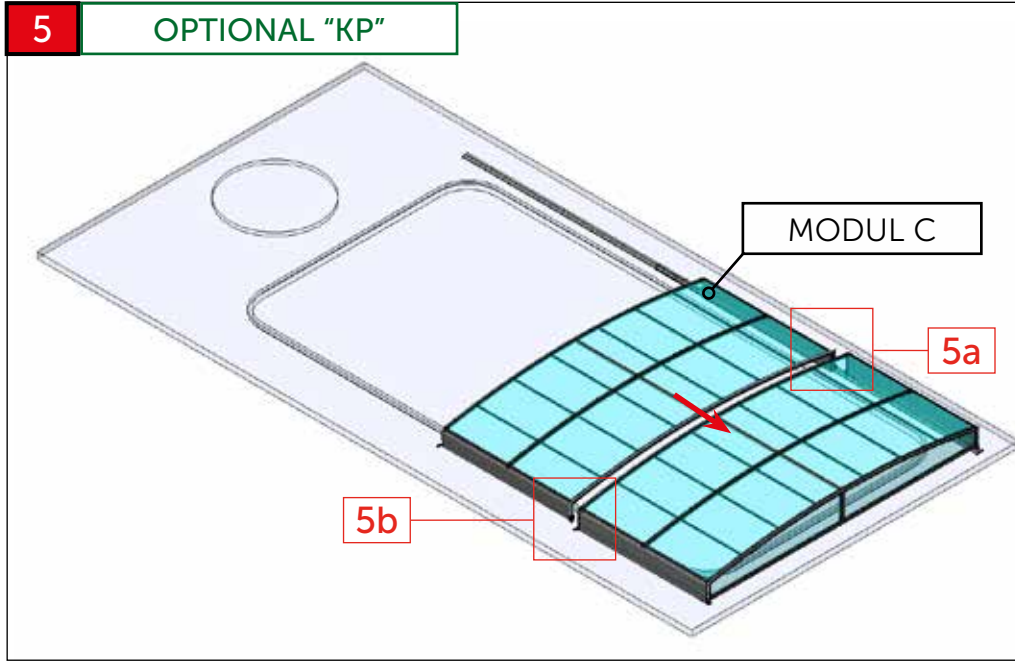

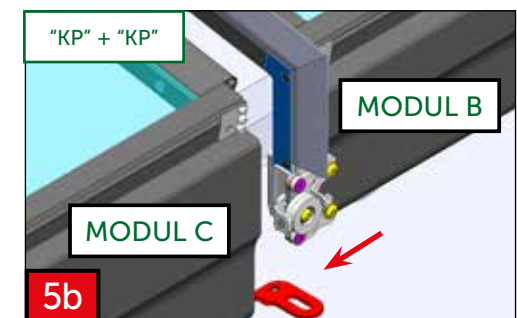
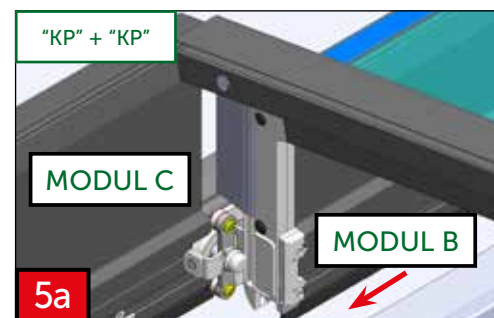
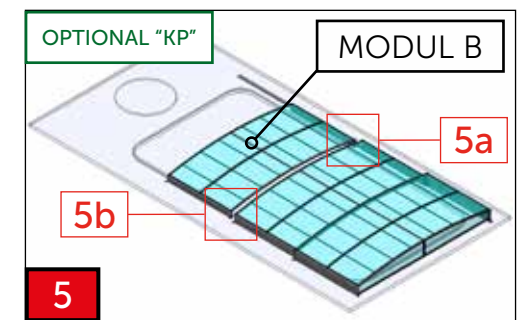
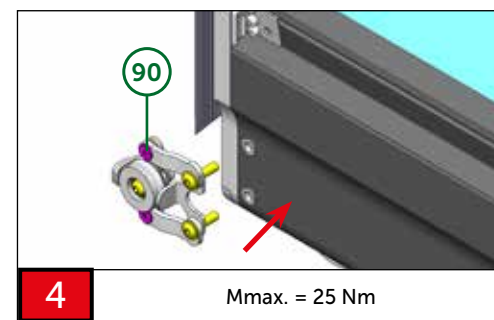
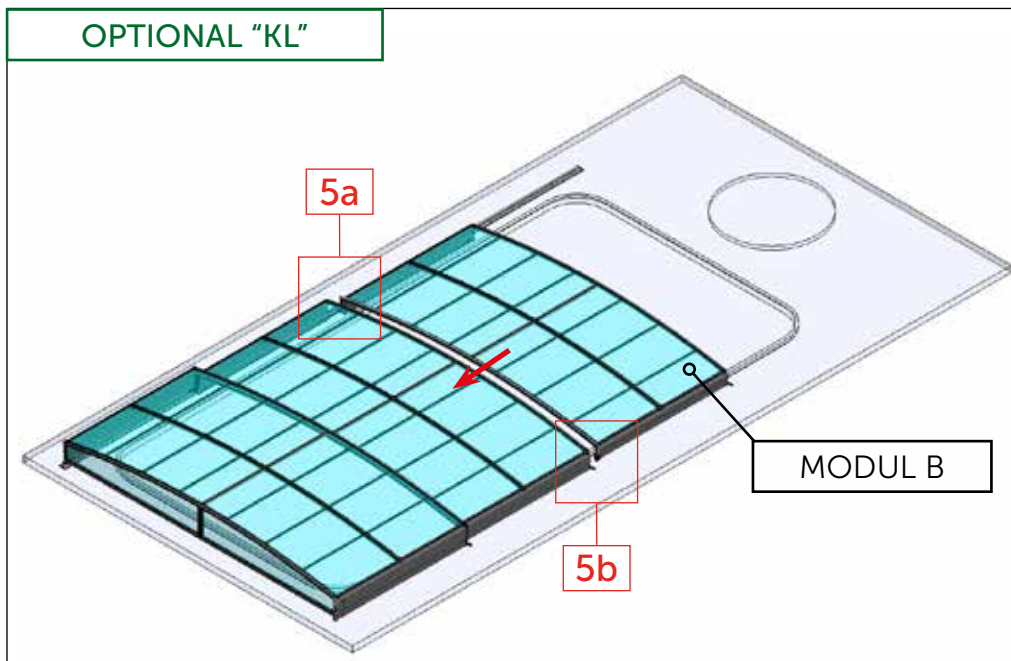
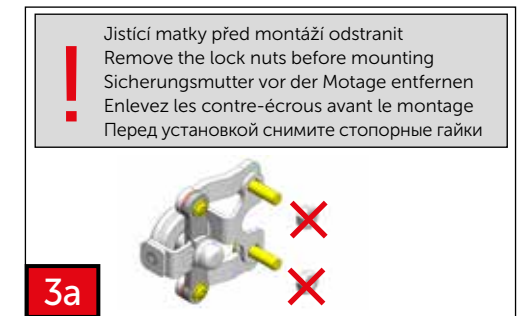
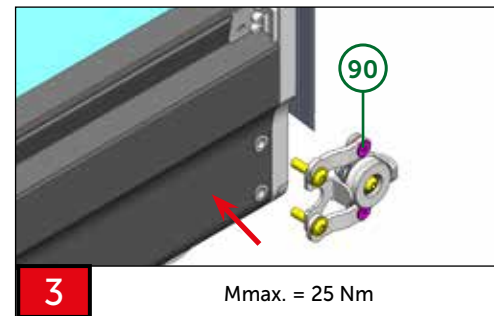
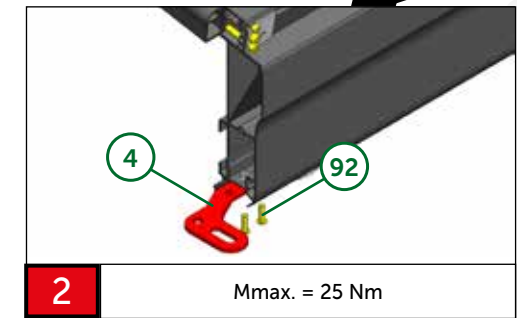
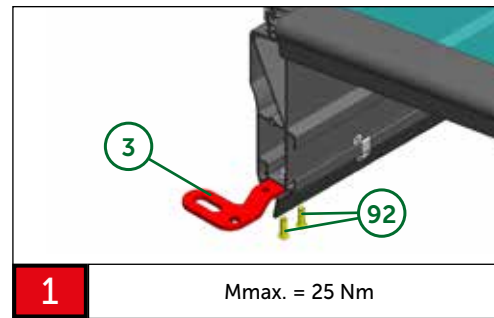
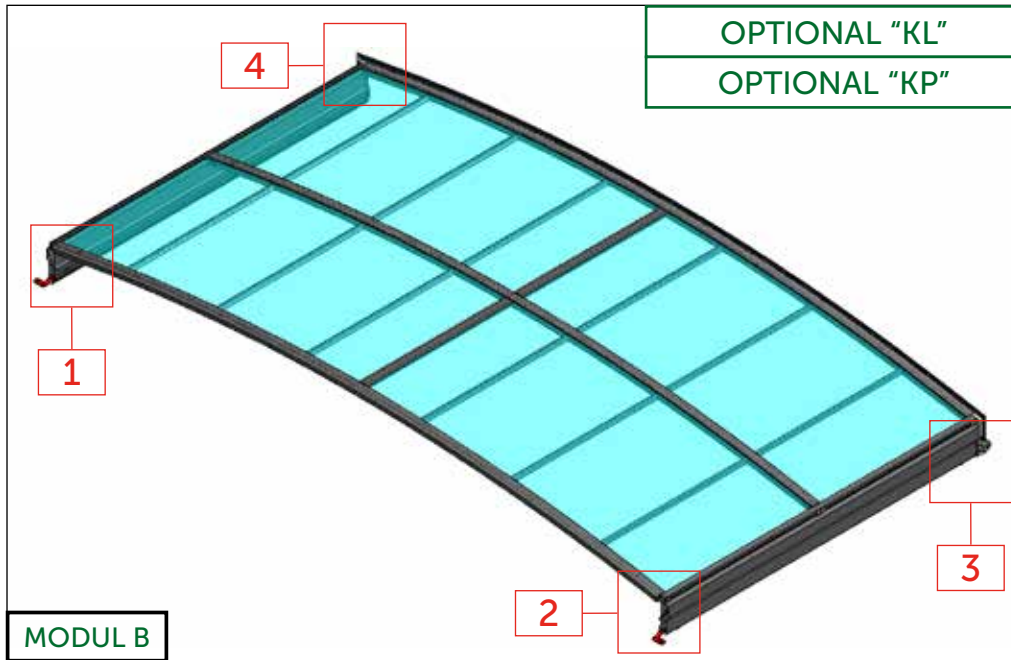

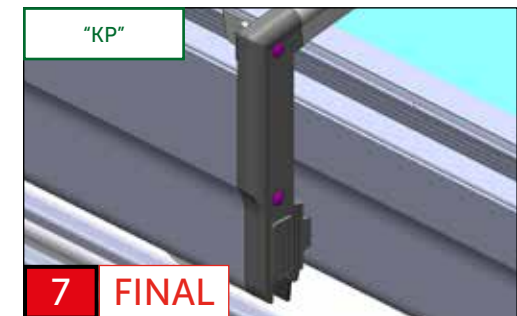
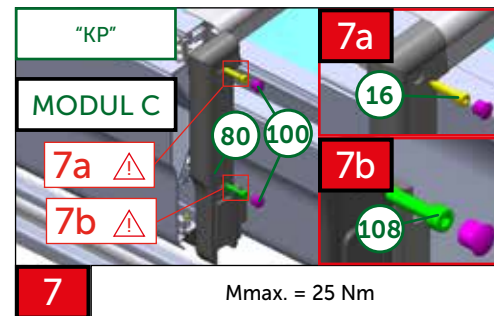
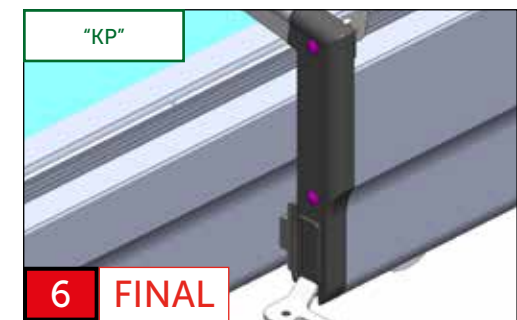
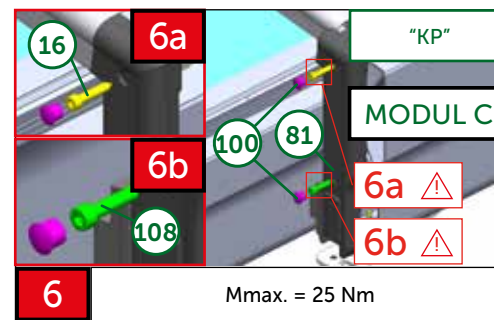
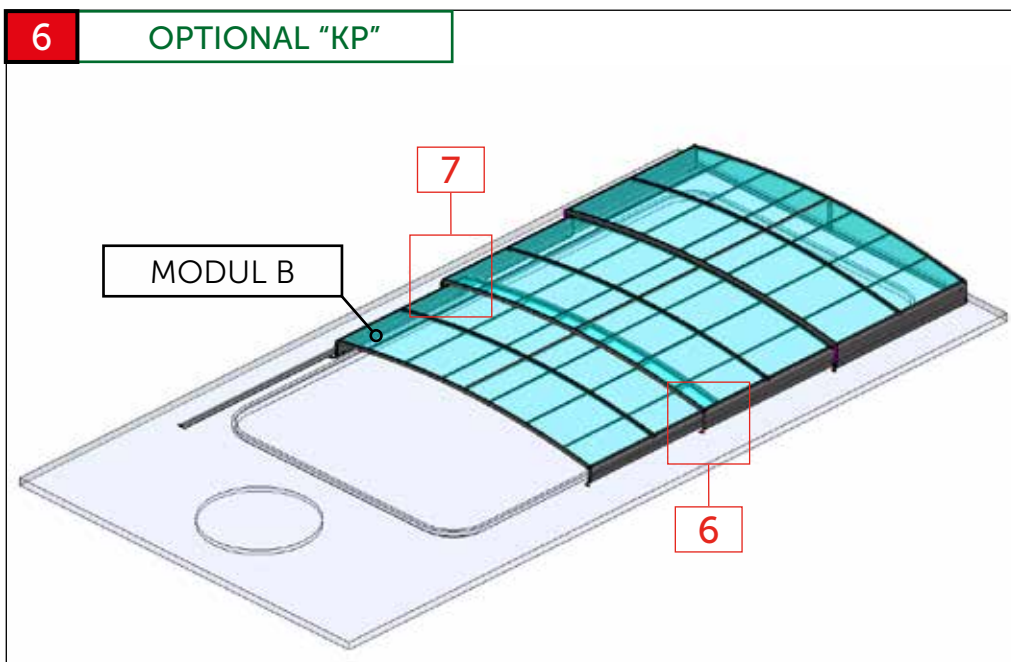
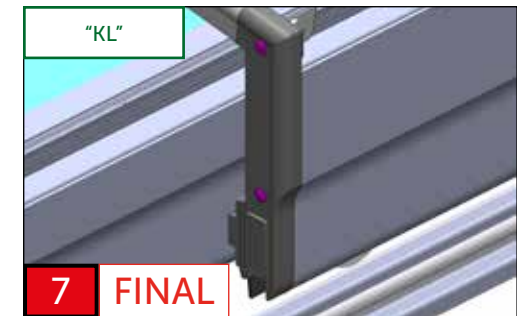
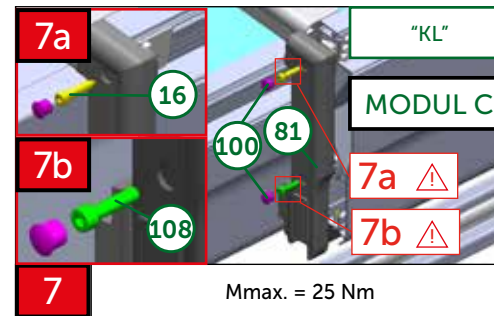
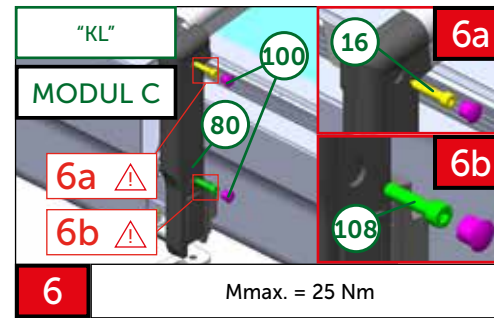
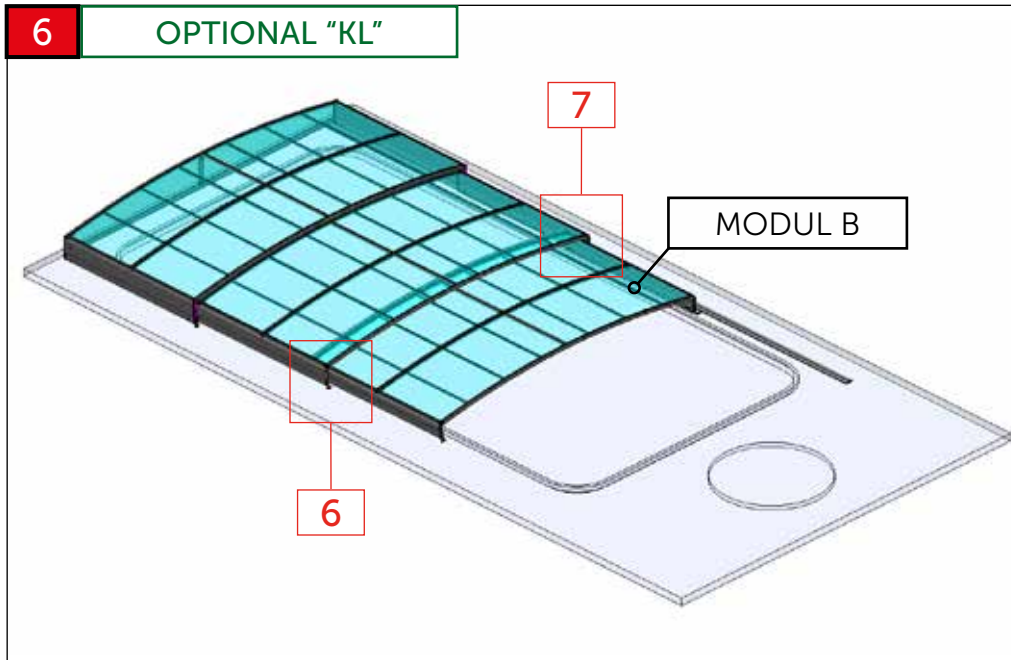

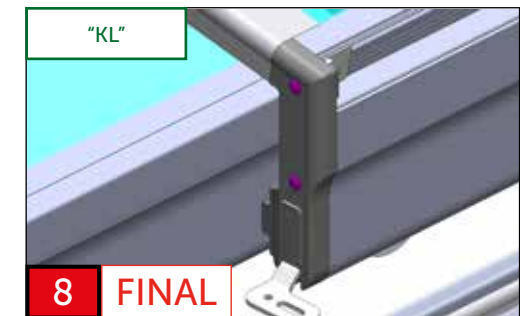
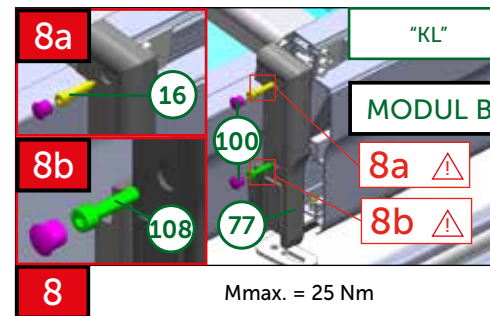
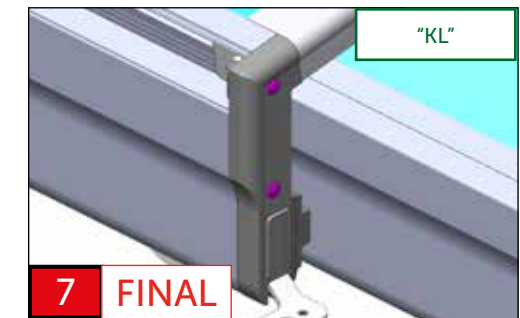
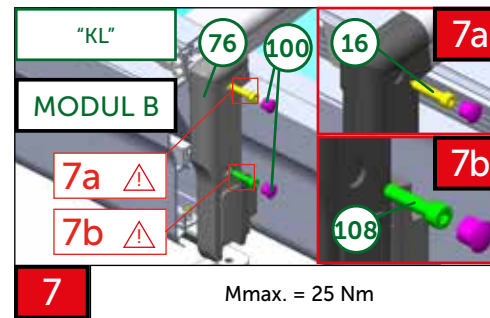
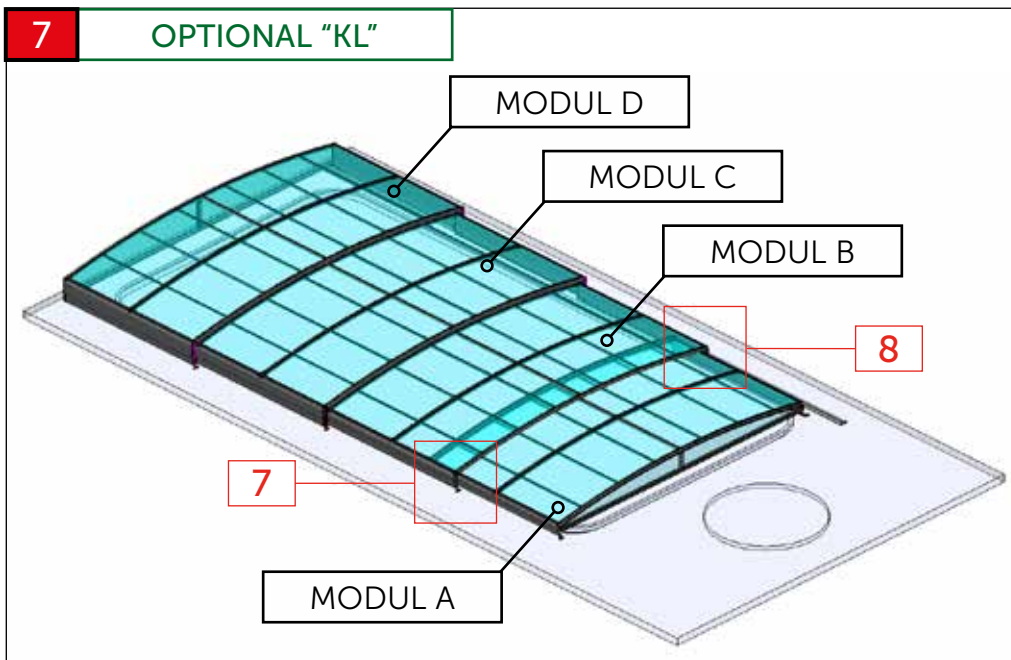
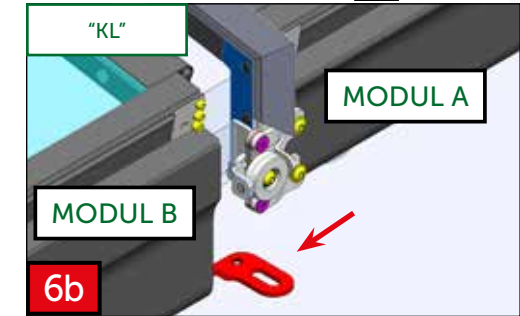
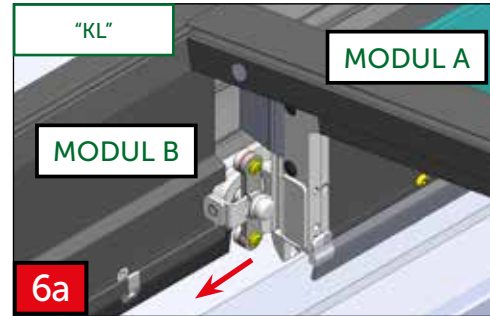
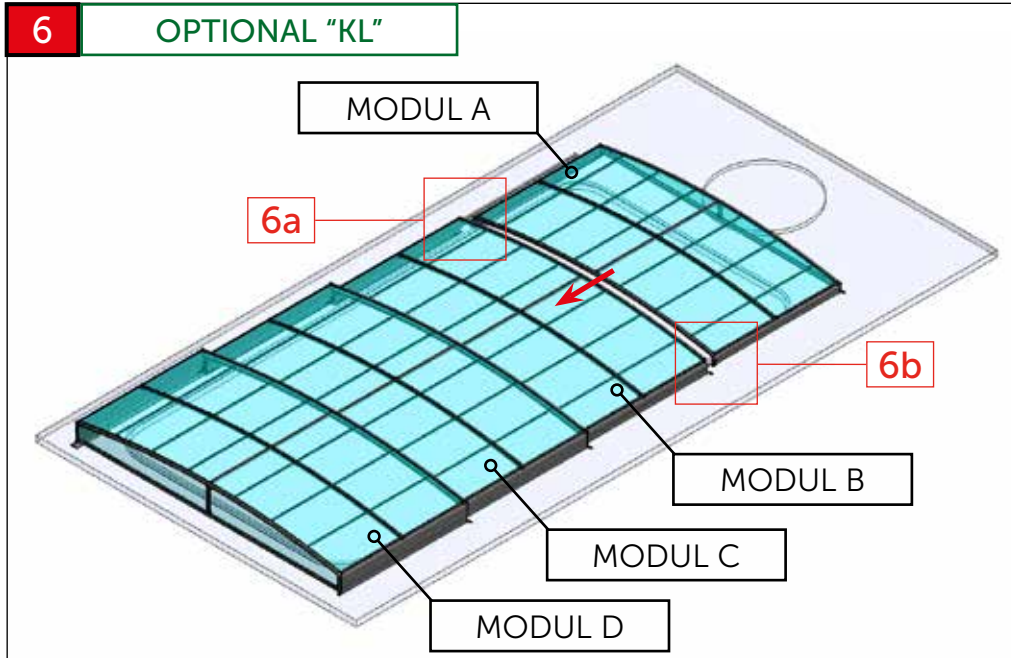

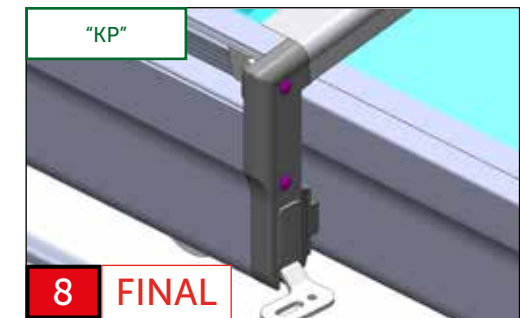
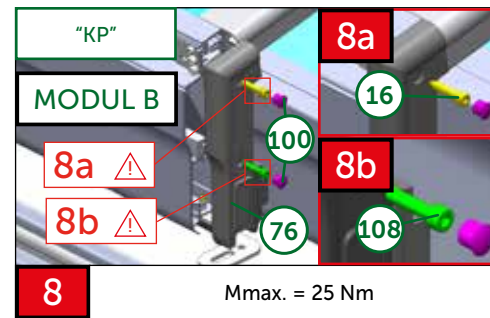
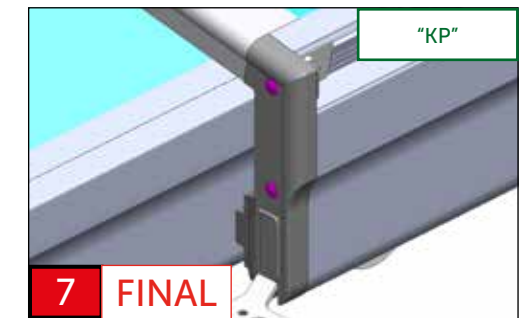
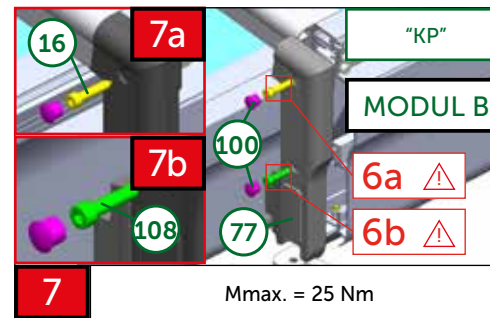
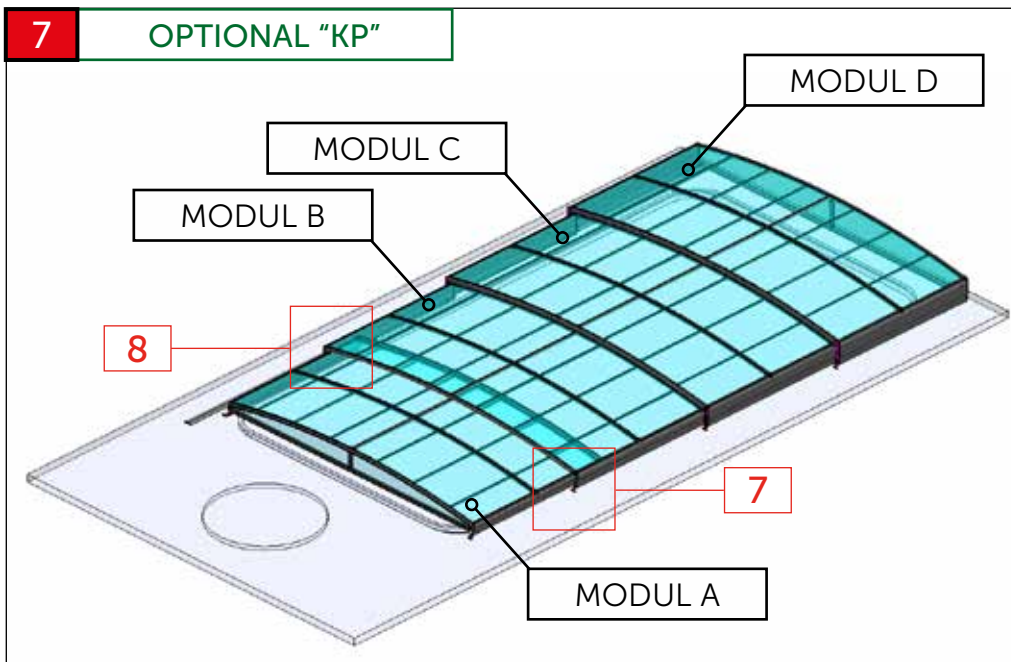
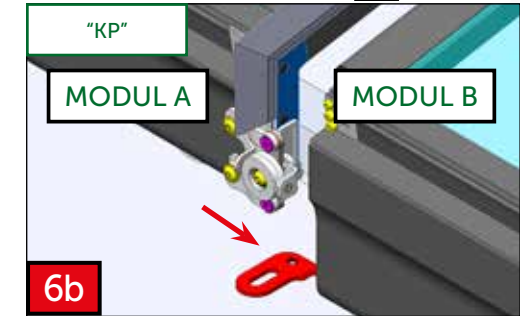
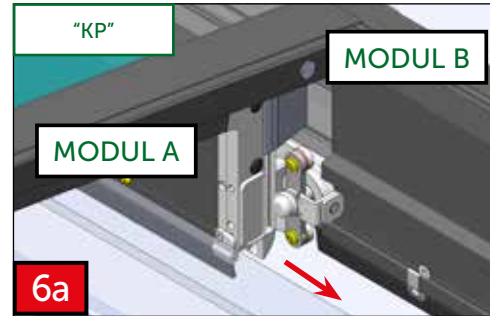
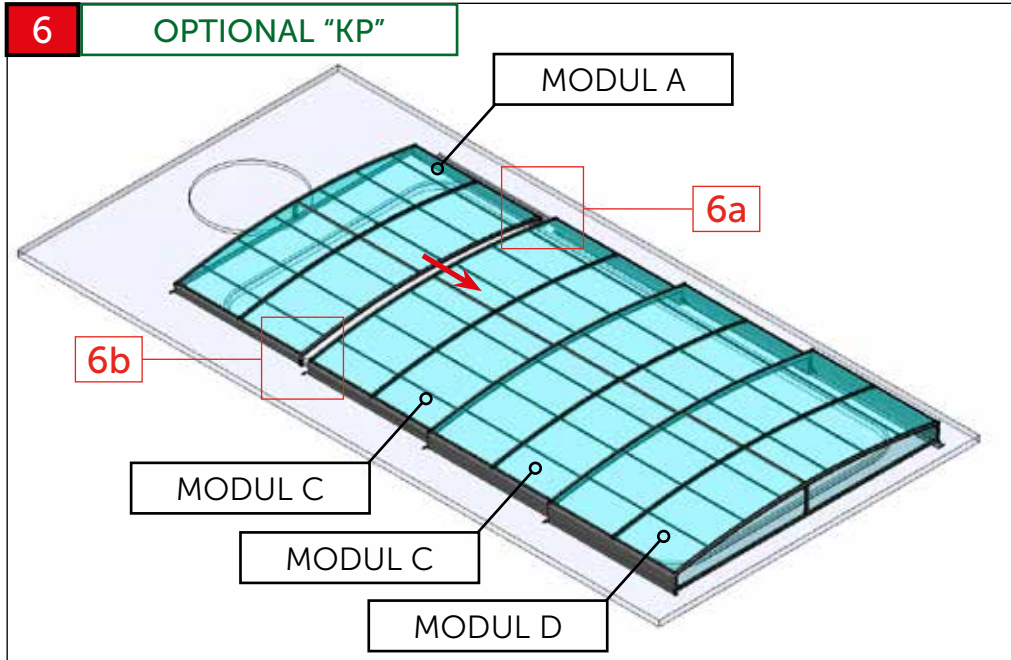

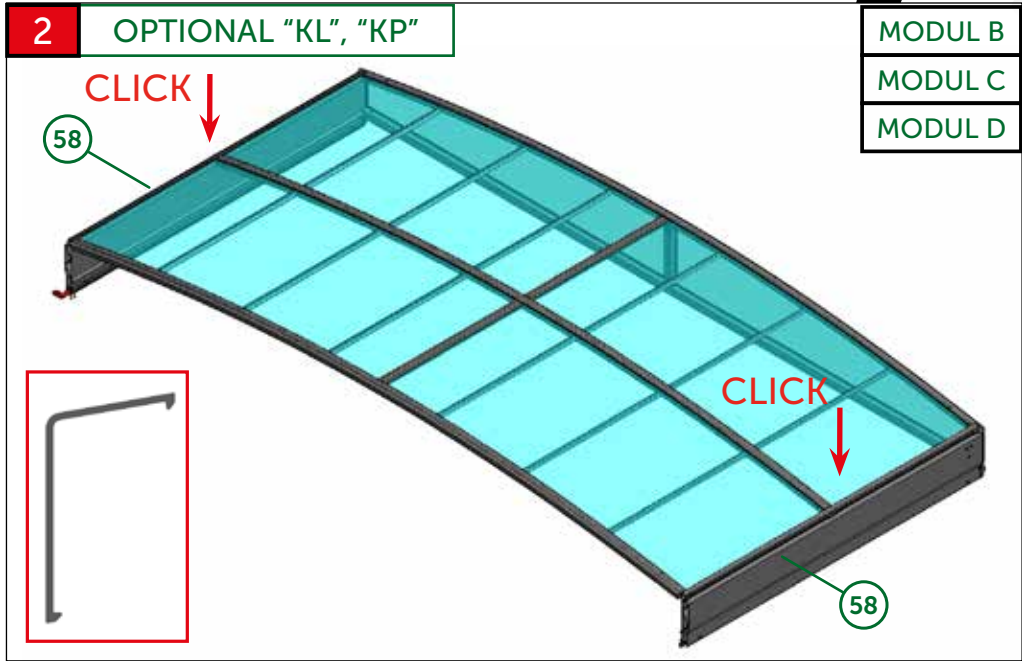
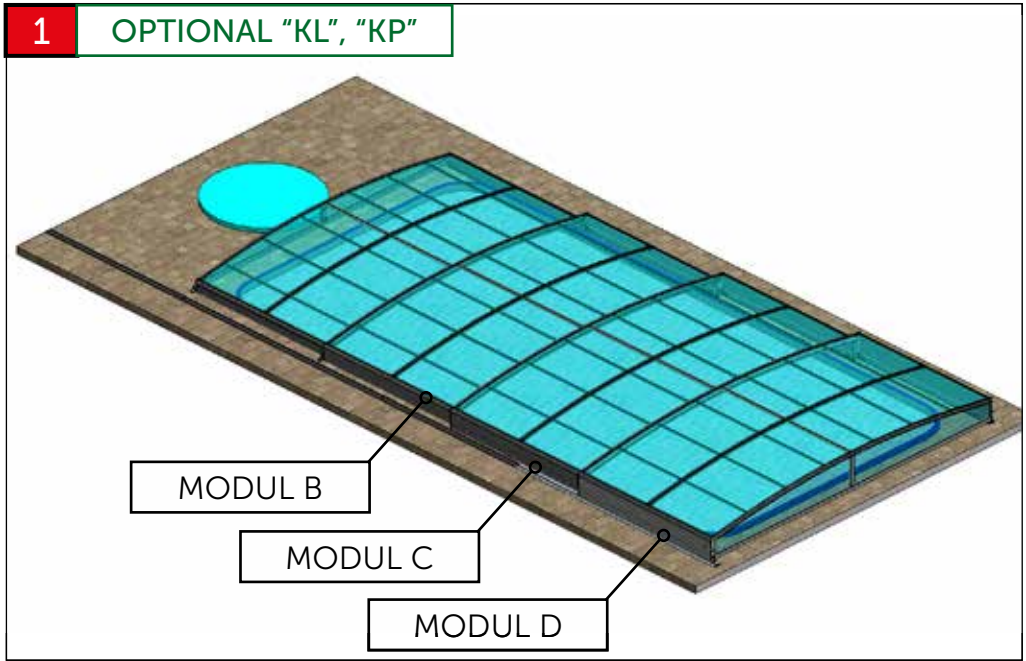

- MODUL B
- MODUL C
- MODUL D

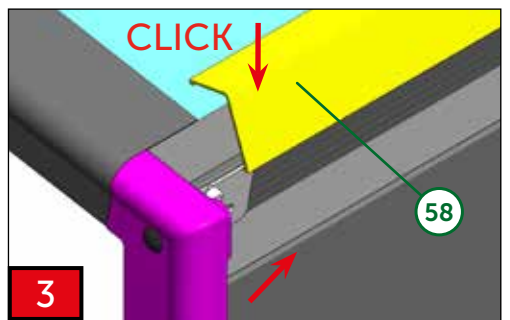

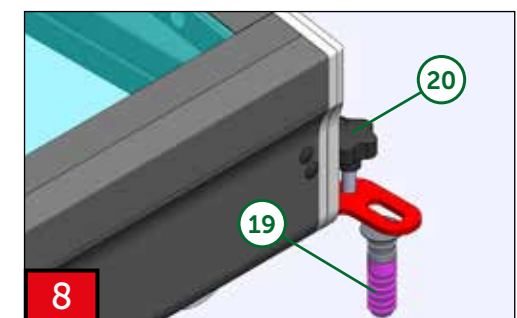
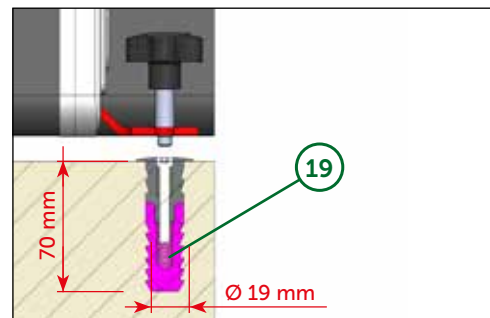
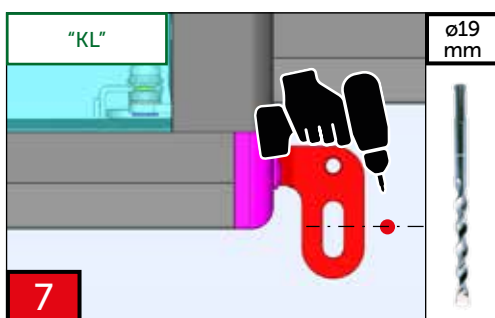
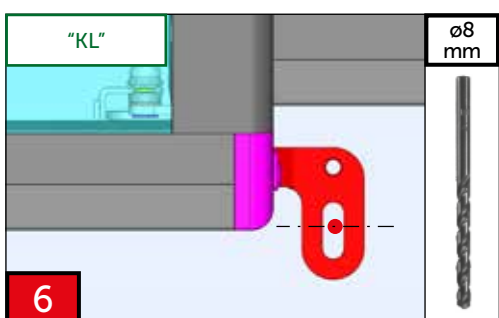
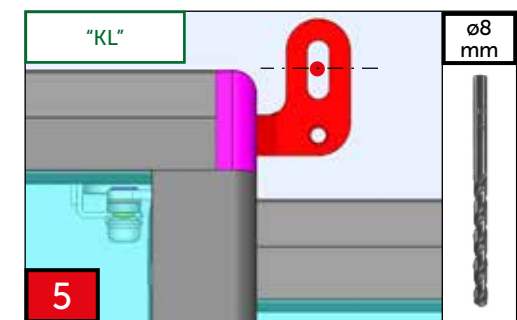
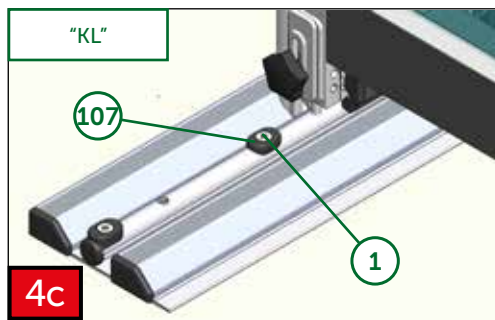
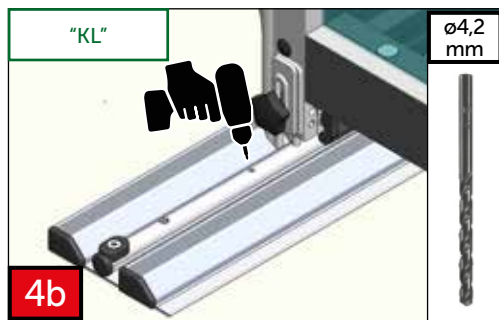
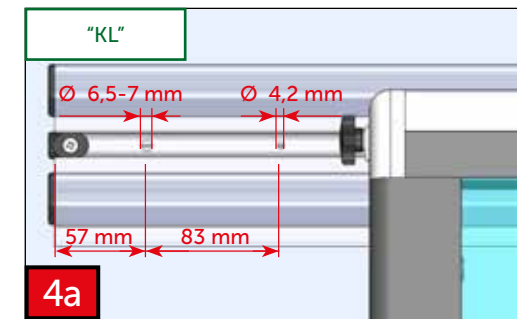
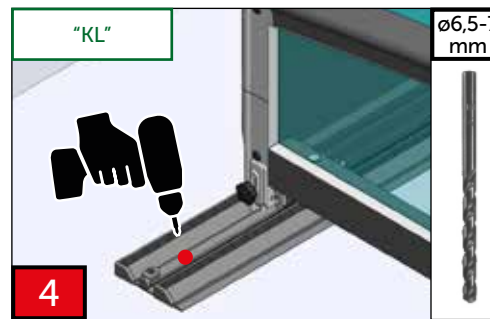
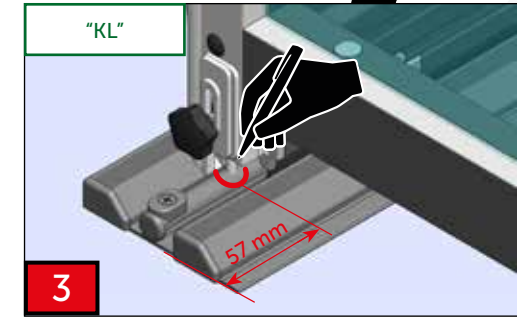
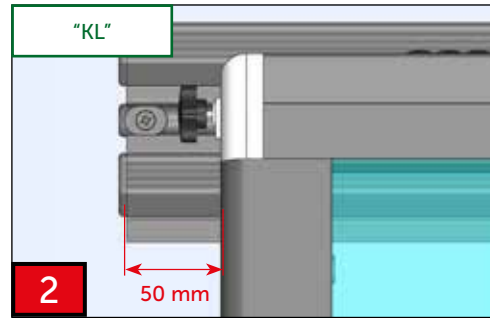
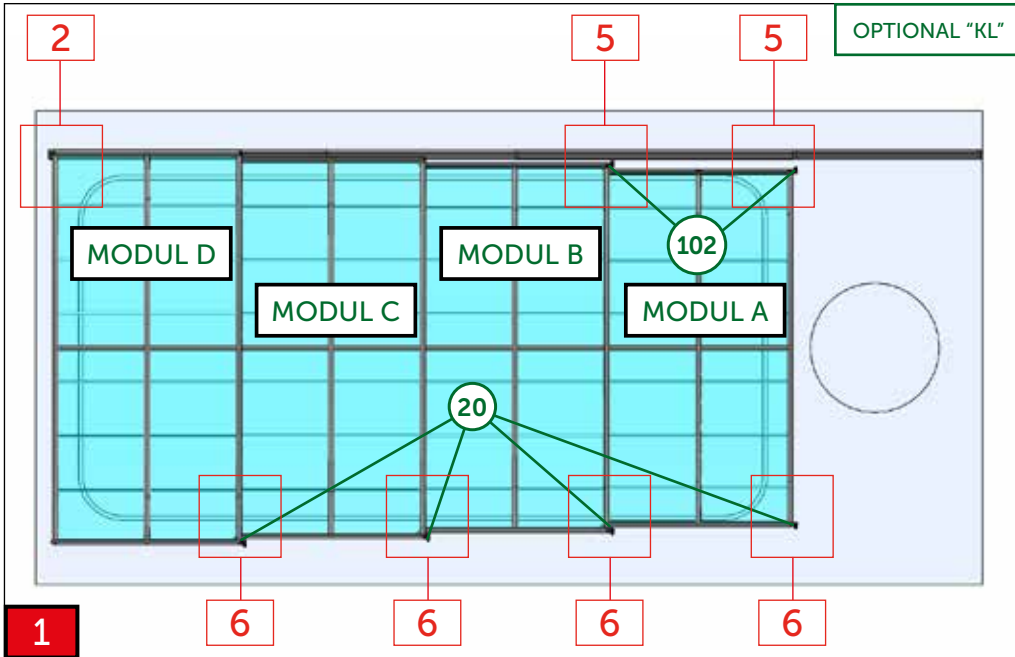

Pouze pro dřevěné a dřevoplastové podlahy
 Only for wooden and wood-plastic floors
 Nur für Holz- und Holz-Kunststoffböden
 Uniquement pour les planchers en bois et en bois-plastique
 Только для деревянных и древесно-пластиковых полов

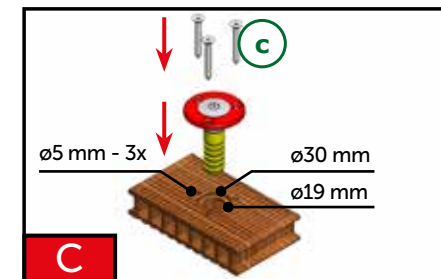
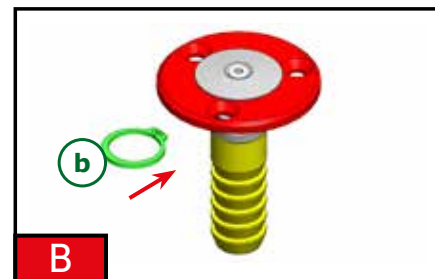
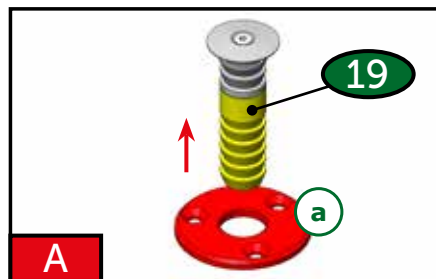

1 OPTIONAL "KL"

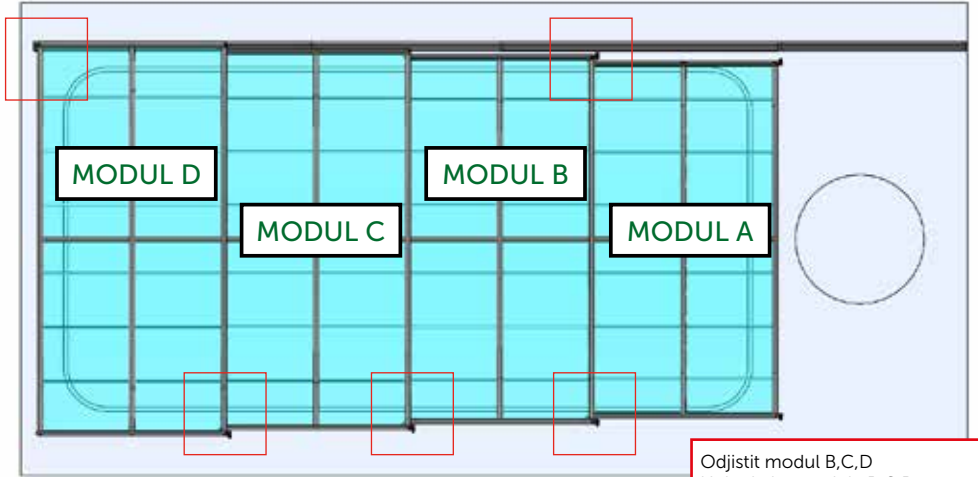

Odjistit modul B,C,D
Unlock the module B,C,D
Modul B,C,D entsperren
Déverrouiller le module B,C,D
Разблокировать модуль B,C,D

2 OPTIONAL "KL"

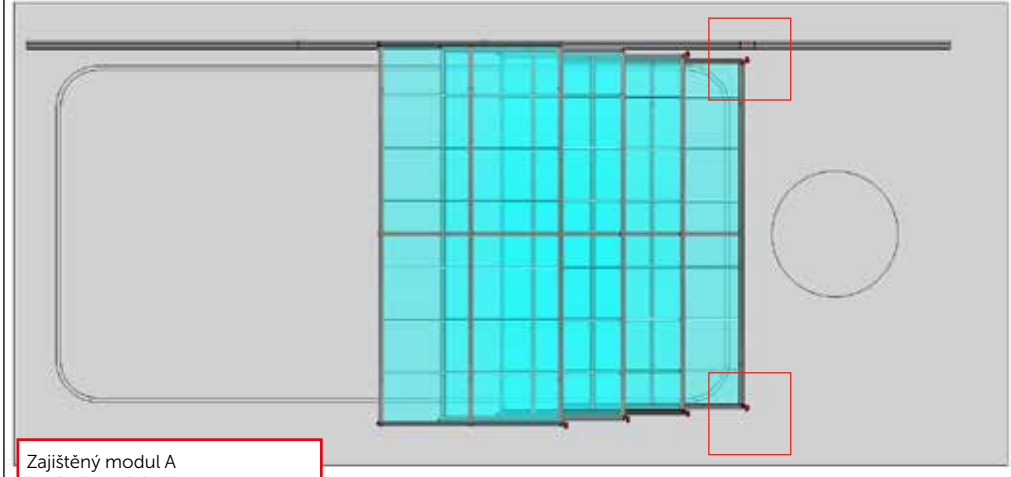

Zajištěný modul A
Locked module A
Modul A gesperrt
Module A verrouillé
Заблокированный модуль A

3 OPTIONAL "KL"

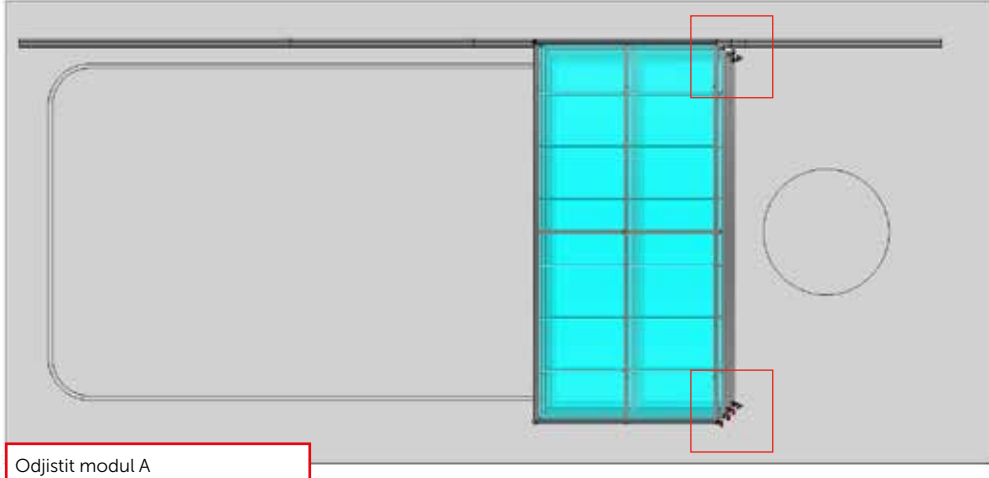

Odjistit modul A
Unlock the module A
Modul A entsperren
Déverrouiller le module A
Разблокировать модуль A

4 PARKING OPTIONAL "KL"

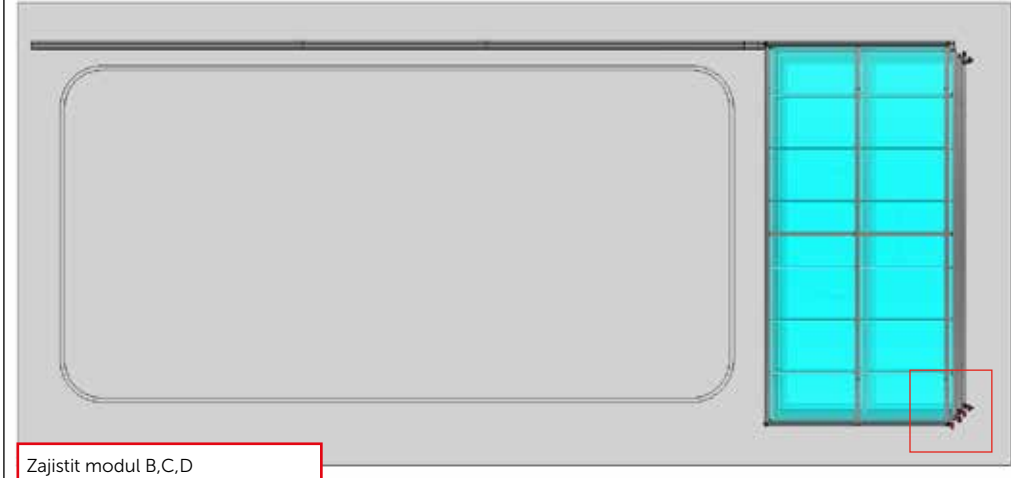

Zajistit modul B,C,D
Lock the module B,C,D
Modul A,B,C,D sperren
Module de verrouillage B,C,D
Блокировать модуль B,C,D

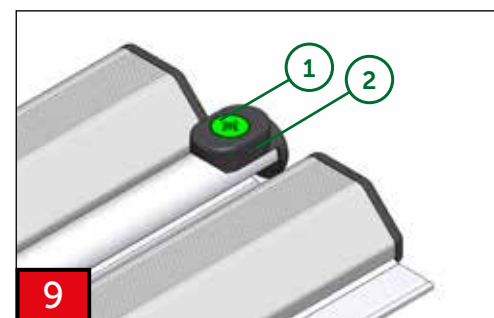
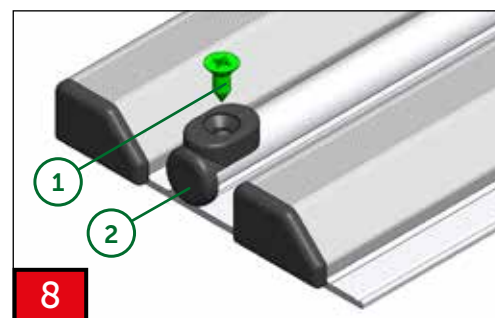
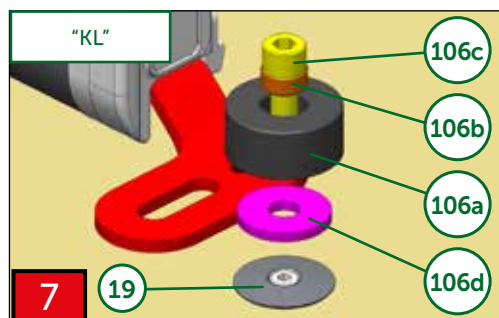
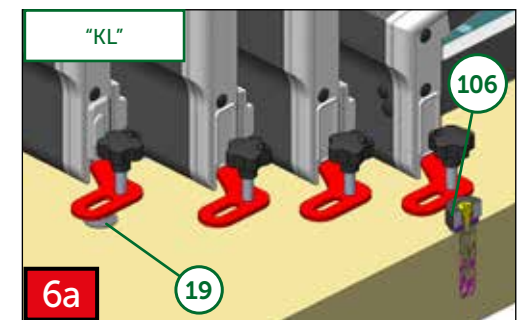
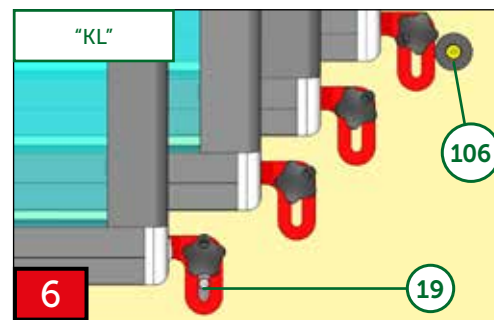
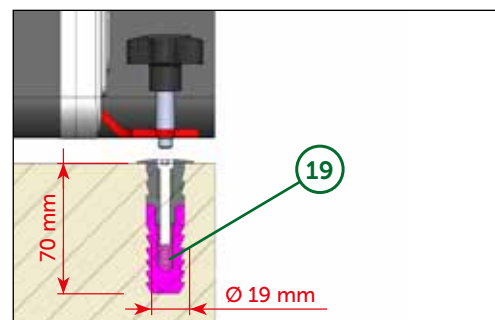
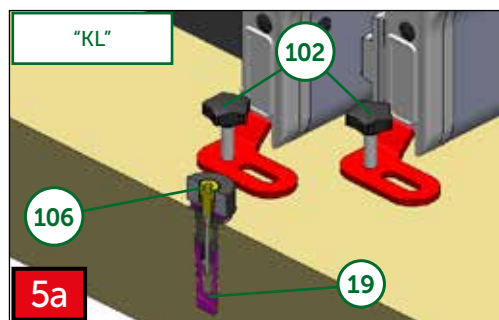
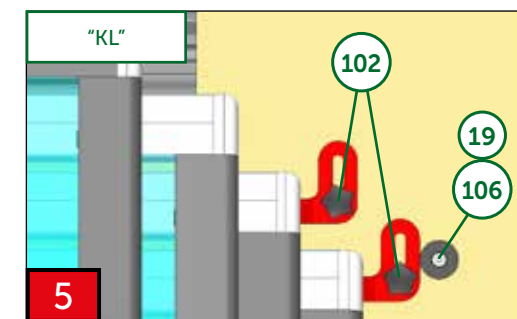
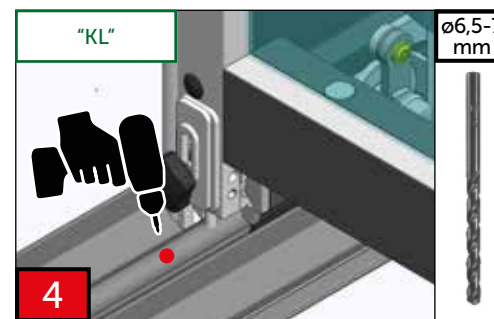
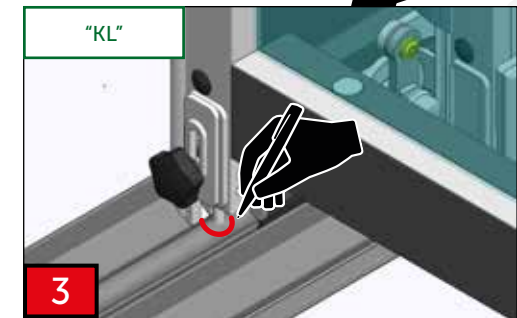
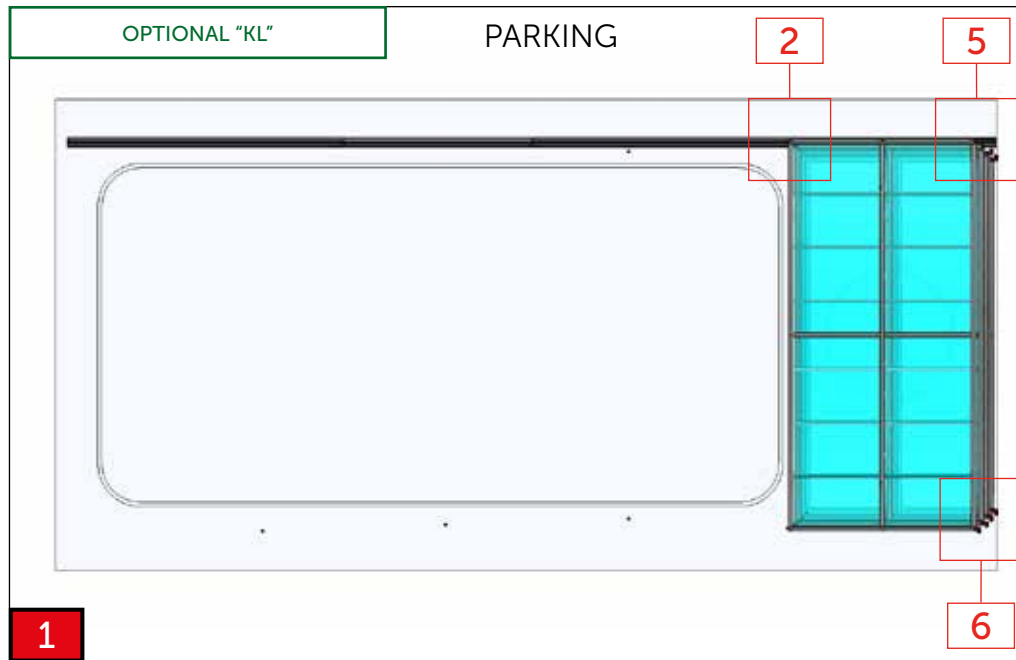

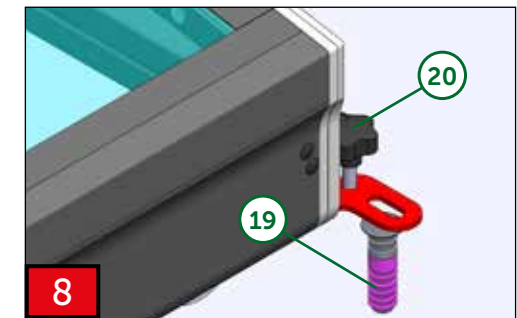
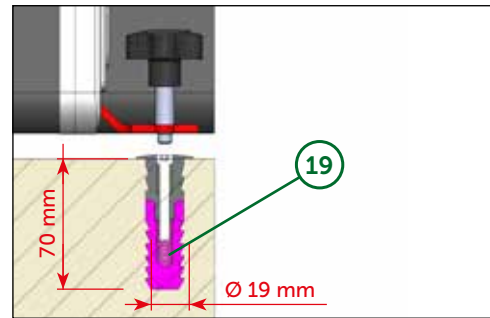
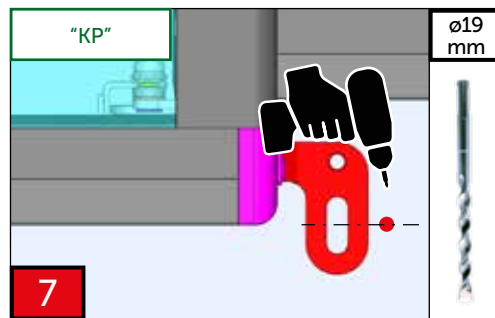
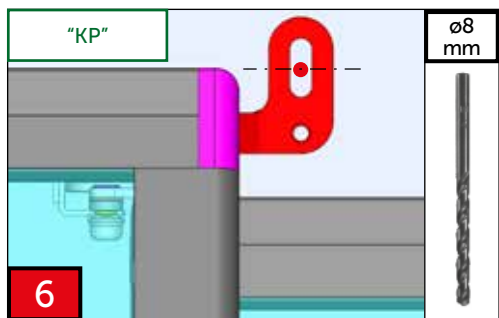
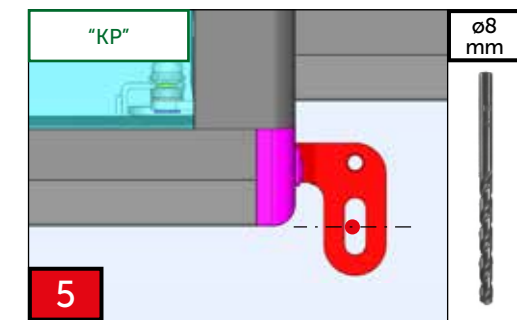
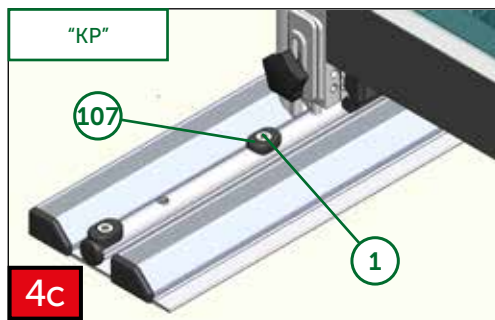
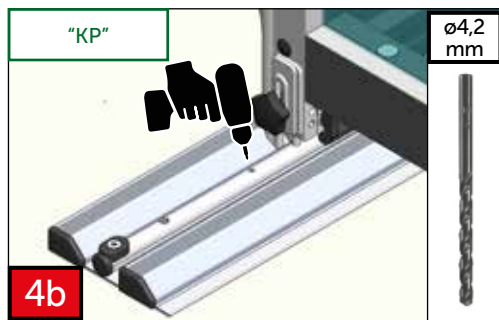
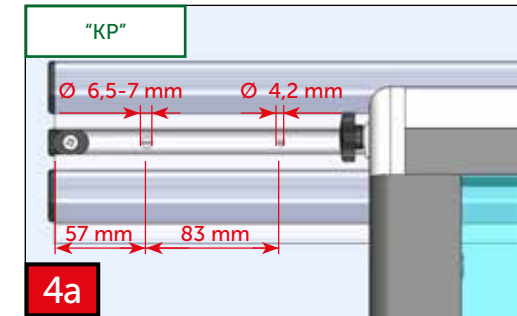
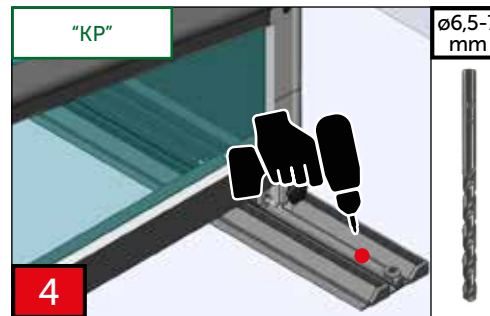
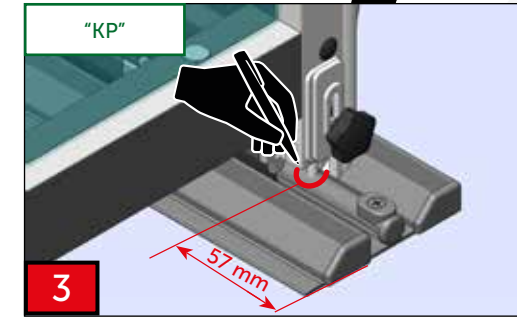
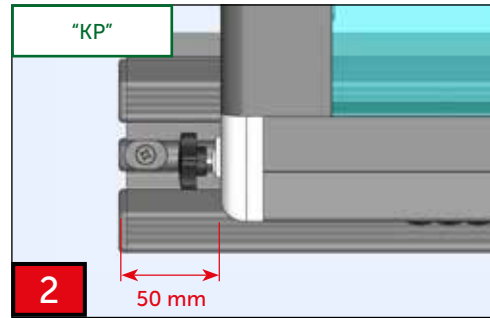
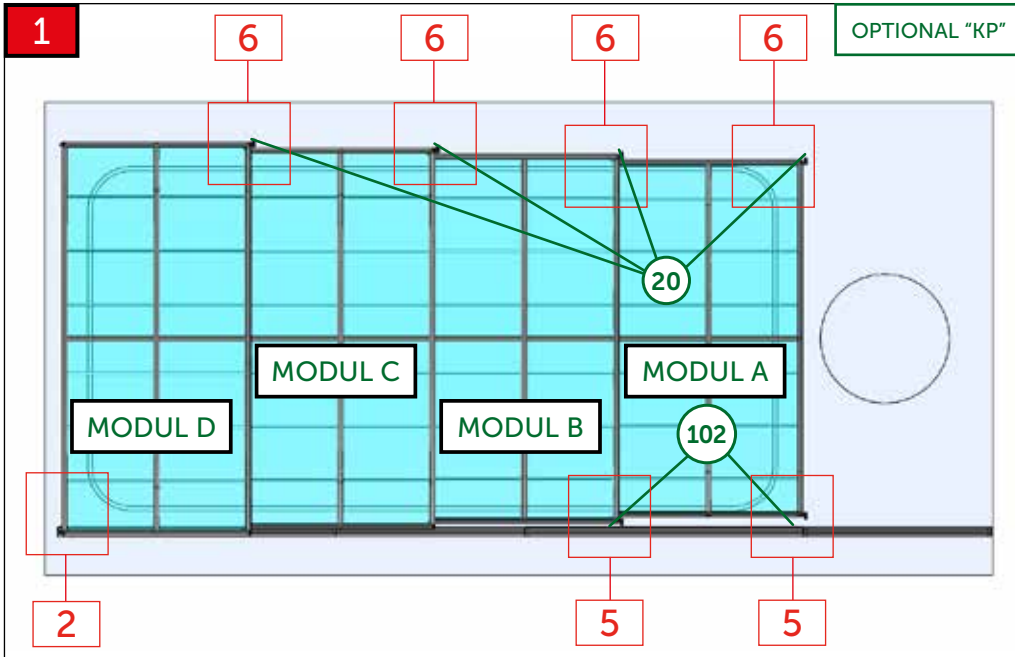

Pouze pro dřevěné a dřevoplastové podlahy
Only for wooden and wood-plastic floors
Nur für Holz- und Holz-Kunststoffböden
Uniquement pour les planchers en bois et en bois-plastique
Только для деревянных и древесно-пластиковых полов

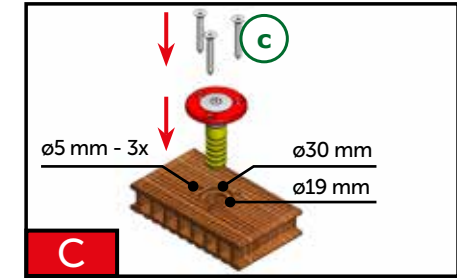
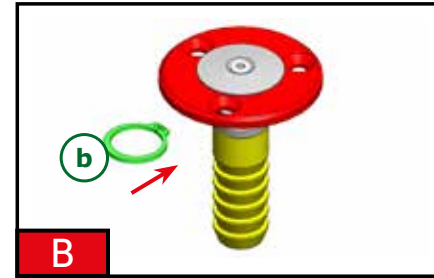
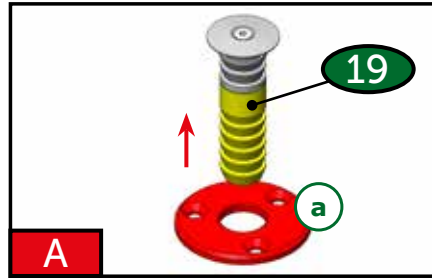

1 OPTIONAL "KP"

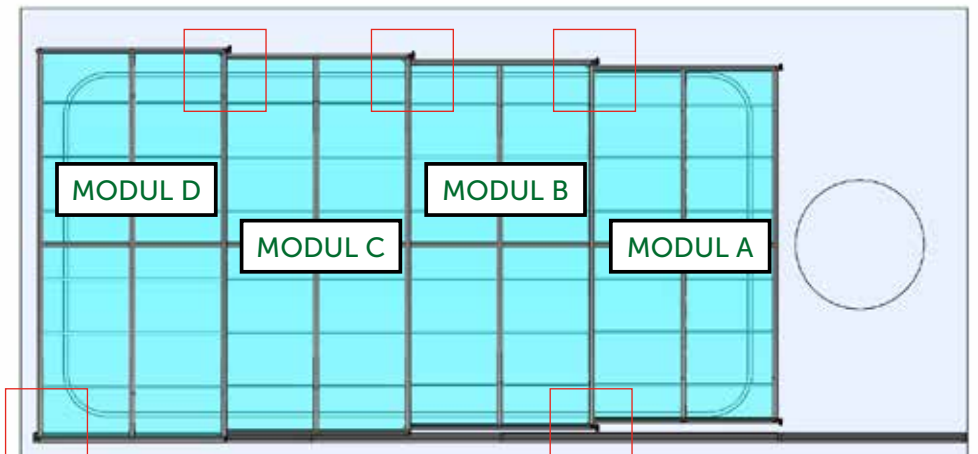

MODUL D
MODUL C
MODUL B
MODUL A

Odjistit modul B,C,D
Unlock the module B,C,D
Modul B,C,D entsperren
Déverrouiller le module B,C,D
Разблокировать модуль B,C,D

2 OPTIONAL "KP"

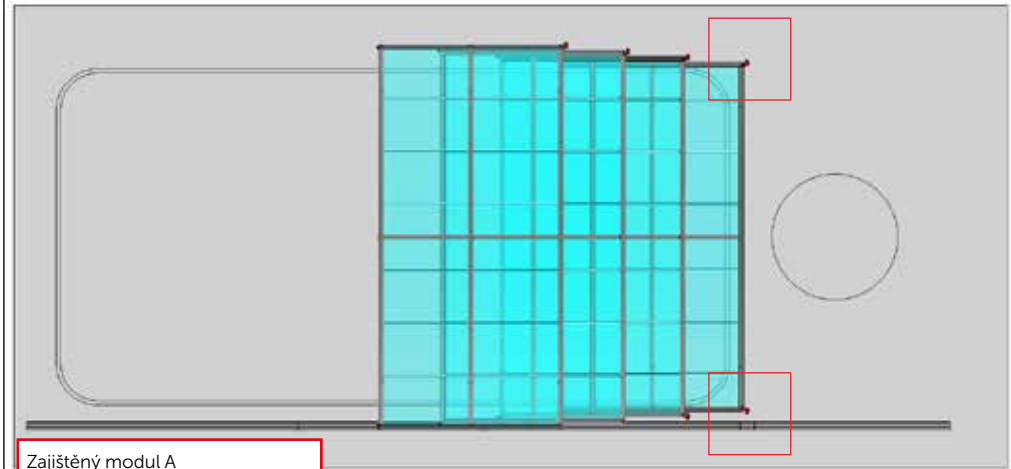

Zajištěný modul A
Locked module A
Modul A gesperrt
Module A verrouillé
Заблокированный модуль A

3 OPTIONAL "KP"

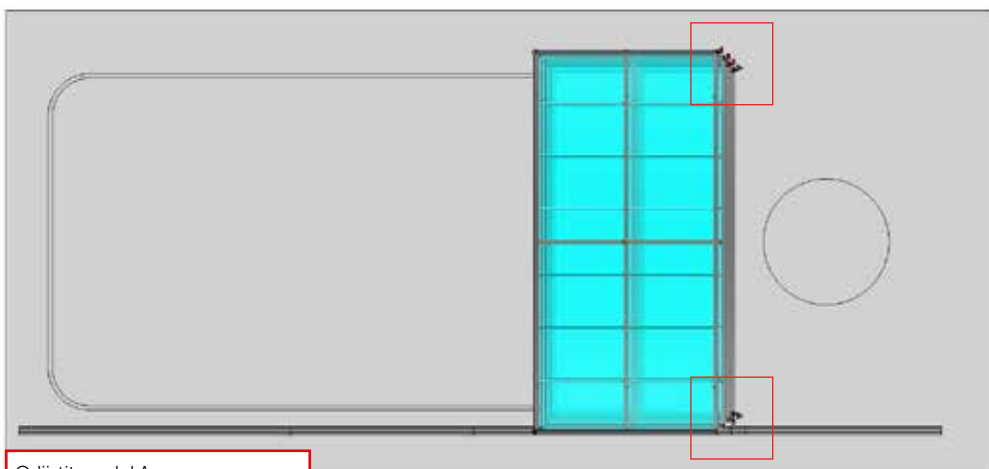

Odjistit modul A
Unlock the module A
Modul A entsperren
Déverrouiller le module A
Разблокировать модуль A

4 PARKING OPTIONAL "KP"

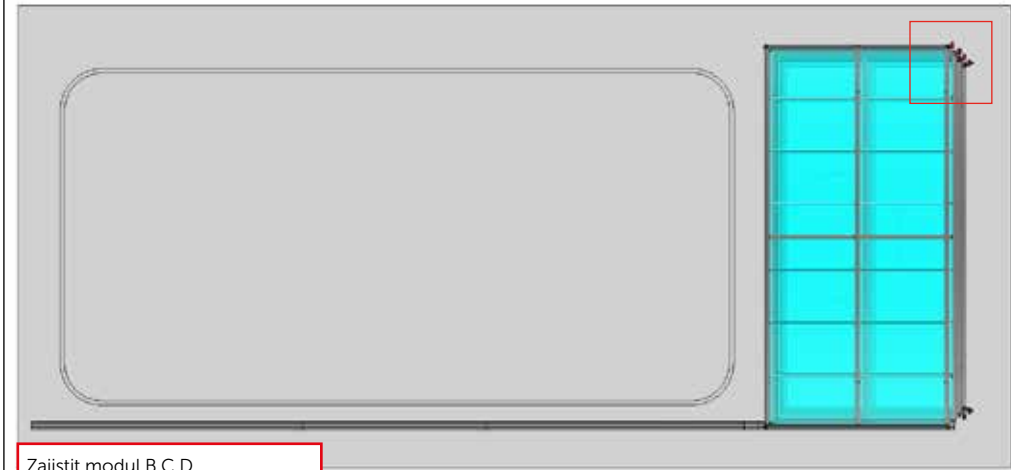

Zajistit modul B,C,D
Lock the module B,C,D
Modul A,B,C,D sperren
Module de verrouillage B,C,D
Блокировать модуль B,C,D

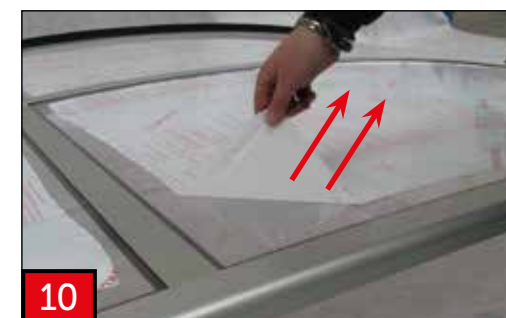
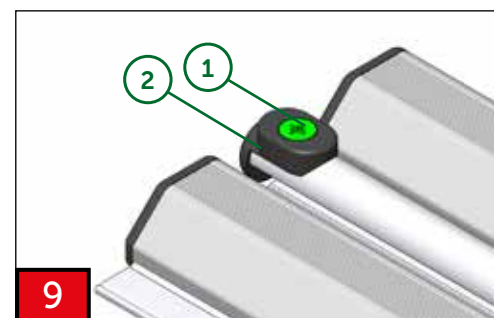
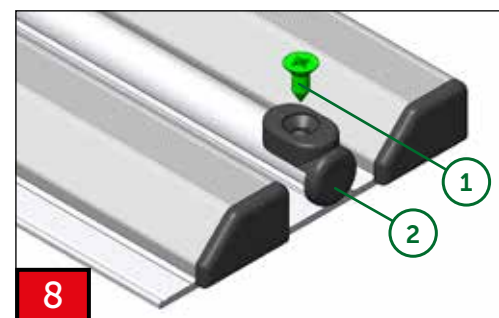
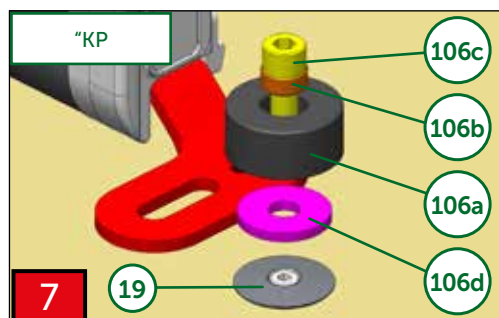
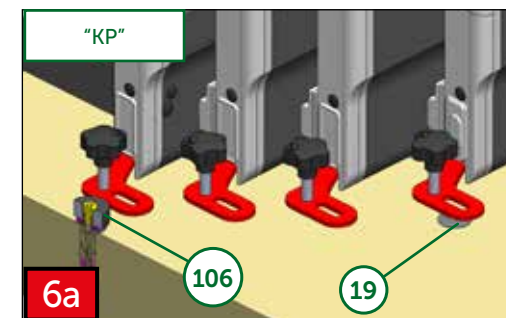
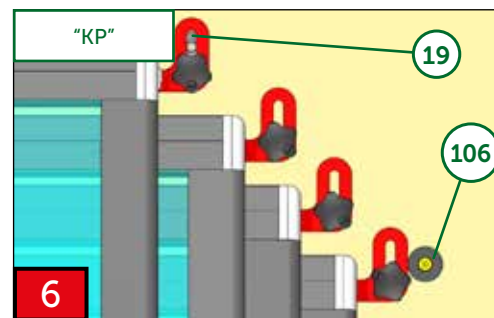
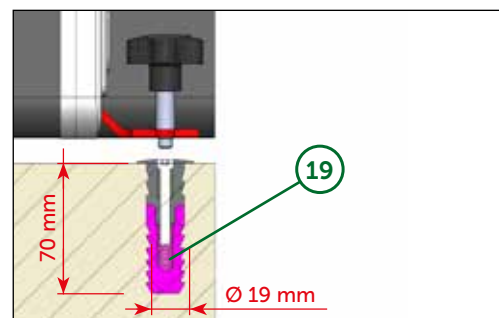
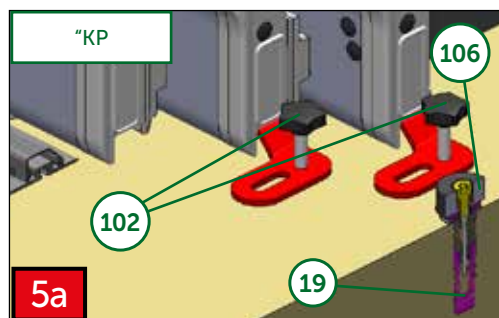
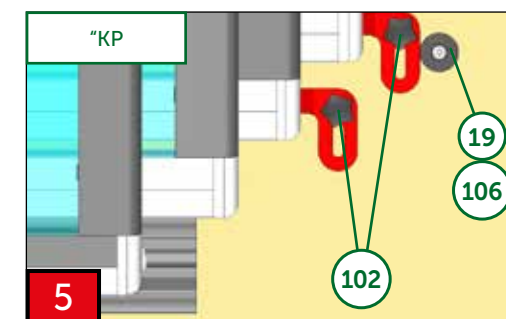
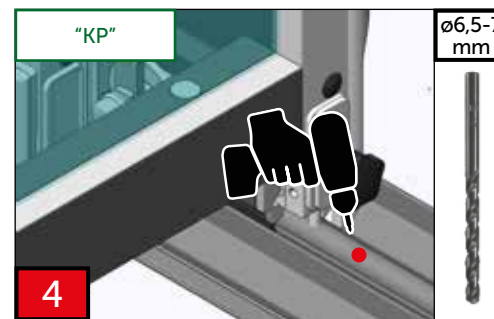
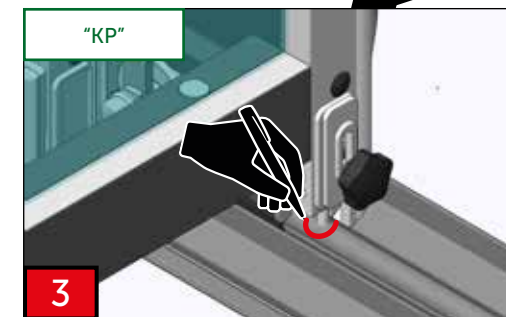
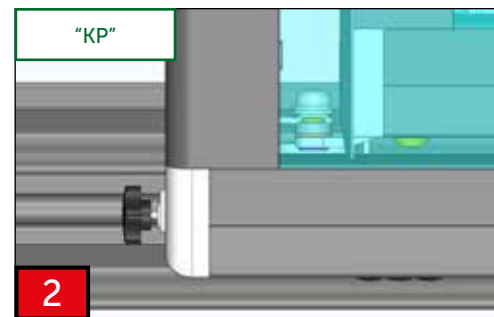
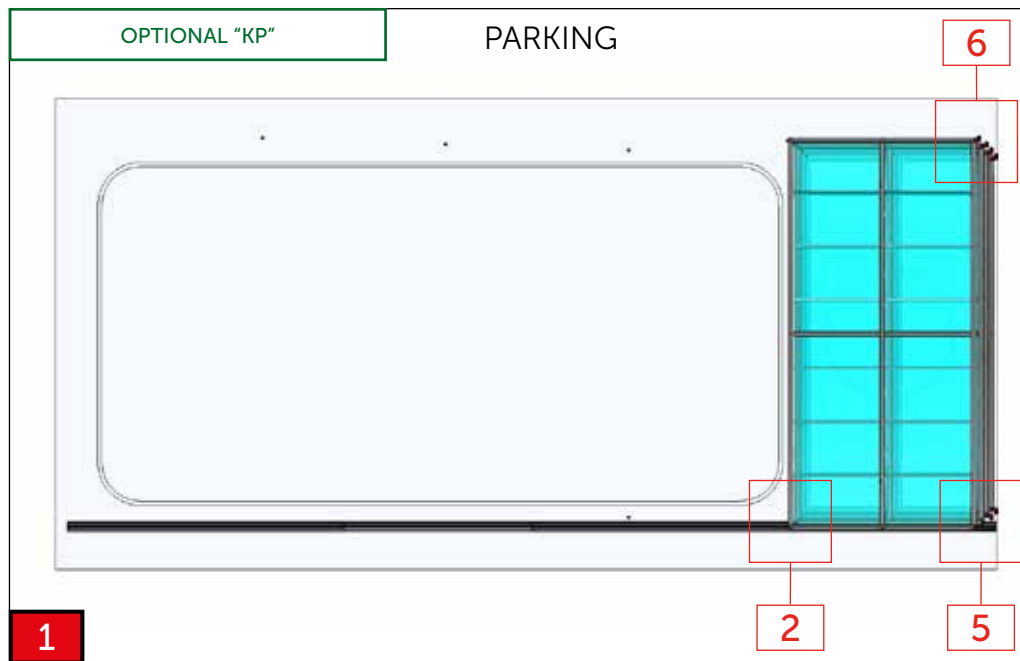



CZ

Dodavatel si vyhrazuje právo na změny a úpravy technických parametrů uváděných v tomto katalogu s ohledem na technický vývoj a zdokonalení výrobků a balení. Dodavatel si vyhrazuje právo na tiskové chyby a chyby v sazbě. Před montáží si pozorně přečtěte návod. Návod si uchovejte pro pozdější použití.

DE

Der Lieferant behält sich das Recht auf Änderungen und Anpassungen der technischen Parameter, die in diesem Katalog aufgeführt sind, mit Rücksicht auf die technische Entwicklung und Verbesserung der Produkte und Verpackung vor. Der Lieferant behält sich das Recht auf Druckfehler und Fehler im Satz vor. Vor der Montage lesen Sie bitte die Anleitung sorgfältig durch. Bewahren Sie die Anleitung für spätere Verwendung auf.

EN

The supplier reserves the right for modifications and adaptations of the technical parameters stated in this catalogue, considering the technical development and upgrade of the products and packaging. The supplier reserves the right for print errors and typographical errors. Please read the manual carefully before you will start the installation. Keep the manual for later use.

ES

El proveedor se reserva el derecho de hacer cambios y modificaciones técnicas de los parámetros que figuran en este catálogo, con respecto al desarrollo técnico mejorando los productos y embalajes. El proveedor se reserva también el derecho a errores de impresión y composición. Antes de empezar la instalación, lea atentamente las instrucciones. Guarde las instrucciones para su uso posterior.

FR

Le fabricant se réserve le droit de modifier les paramètres techniques cités dans ce manuel en considération du développement technique et de l'amélioration des produits et de leur emballage. Le fabricant se réserve le droit des fautes d'impression et de composition. À lire attentivement et à conserver pour une consultation ultérieure.

HU

Gyártó fenntartja jogát a katalógusban feltüntetett műszaki paraméterek változtatására a termékek és csomagolás technikai fejlesztése és tökéletesítése szerint. Szállító: a szállító fenntartja jogát a nyomtatási és szedési hibákra.

IT

Il fornitore si riserva il diritto di effettuare modifiche e correzioni ai parametri tecnici riportati nel presente catalogo per migliorare e perfezionare dal punto di vista tecnico i prodotti e gli imballaggi. Il fornitore non esclude inoltre l'eventuale presenza di errori di stampa e di impaginazione. Prima dell'installazione, leggere attentamente le istruzioni. Tenere l'istruzione per un uso successivo.

PL

Dostawca zastrzega sobie prawo do zmian oraz dostosowania parametrów technicznych podanych w niniejszym katalogu z uwzględnieniem rozwoju technicznego i udoskonalania produktów oraz opakowań. Dostawca zastrzega sobie prawo do błędów druku oraz typograficznych.

PT

O provedor reserva-se o direito a efectuar alterações e adaptações de parâmetros técnicos mencionados neste catálogo, tendo em consideração o avanço técnico e melhorias de produtos e embalagens. O provedor reserva-se o direito a cometer erros de impressora e de edição.

RO

Furnizorul își rezervă dreptul de a modifica și schimba parametrii tehnici menționați în acest catalog cu privire la evoluția tehnică și perfecționarea produselor și a ambalării. Furnizorul își rezervă dreptul la greșelile de tipar și greșelile privind tarifele.

RU

Поставщик оставляет за собой право на изменение и исправление технических параметров продукции указанной в этом каталоге, с учетом технического развития, а усовершенствования изделий и его упаковки. Поставщик оставляет за собой право на опечатку в тексте и в ценах. Перед установкой и эксплуатацией изделия внимательно ознакомьтесь с настоящим руководством. Сохраните данное руководство для дальнейшего использования.